

SM 643 PWD/HWD 30-40SE Service Manual

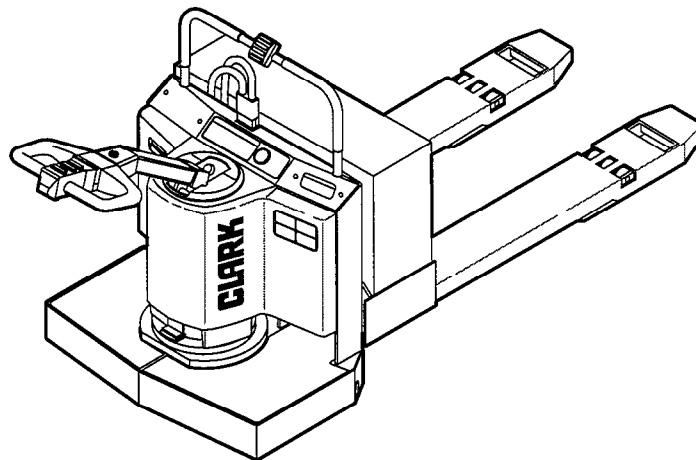
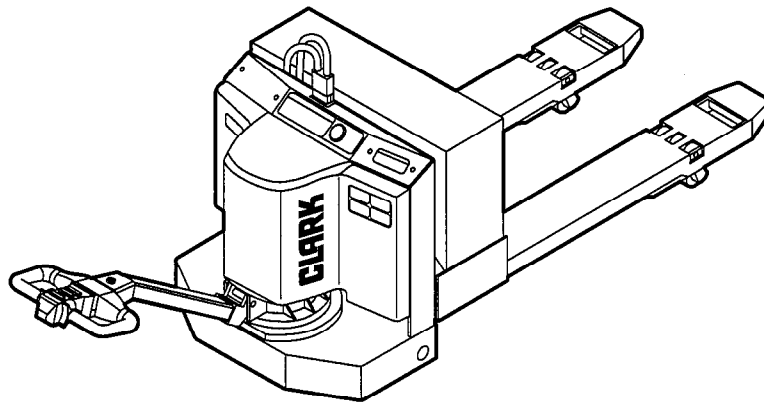

CLARK

Technical
Publications
Lexington, KY
40508

Copyrighted Material
Intended for CLARK dealers only

This is the cut pages sample. Download all 206 page(s) at: ManualPlace.com

Arrangement and Use of this Manual

Clark arranges parts and service procedures by standardized *Groups*. In this manual, Groups are similar to “chapters.” Groups are listed in the table of contents on the next page.

Each Group begins with a table of contents that shows the *Sections* contained within the Group. Lengthy Sections also begin with a table of contents showing the topics contained within the Section.

Each Group and Section has an identifying name and number, or “ID.”

Each page also has a unique ID. The page ID consists of three numbers separated by hyphens. The three numbers represent the Group number, the Section number, and the page number. For example, “00-1-2” on the lower corner of the page indicates Group 00, Section 1, Page 2.

You can quickly locate a specific point in the manual by using the headers and footers that appear on every Section page. The following illustration points out these areas.

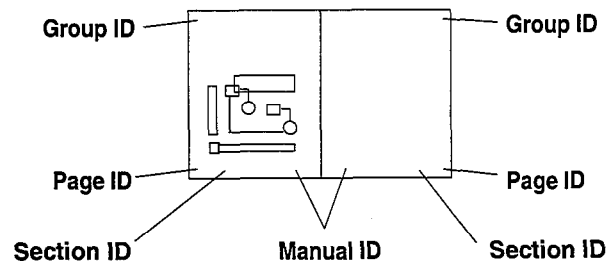

This manual is intended for the use of trained service personnel. Please read Group SA, “Safe Maintenance,” and the *Operator’s Manual* before working on or operating the truck.

Contents by Group

Contents are listed here by Group number:

PS	PERIODIC SERVICE
12	BATTERY
14	WIRING
16	ELECTRIC MOTORS
17	CONTACTORS
19	MOTOR CONTROLS
20	DRIVE UNIT
23	BRAKE SYSTEM
25	CASTER ASSEMBLY
28	HYDRAULIC SYSTEM
34	LIFT CYLINDERS
35	LIFT LINKAGE and LOAD WHEELS
39	SHEET METAL
40	SPECIFICATIONS

GROUP PS

PERIODIC SERVICE

Maintenance Schedule Section 1

Planned Maintenance Program Section 2

The PM Inspection Form Section 3

P.M. CHECK SHEET

A special coding system on the P.M. Check Sheet allows truck condition to be reported with a minimum number of words. As the P.M. is performed, a check mark should be made in the appropriate box of the component being checked.

- (✓) indicates the particular truck component or system has been checked and is O.K.
- (x) indicates the component or system is in need of a minor adjustment or service (not part of the normal P.M.) that should be taken care of in the near future.
- (r) indicates there is a potential problem that could result in damage to a component or system and requires attention.
- (s) indicates the need for urgent repair or replacement of a component or system and the truck should be shut down as eminent damage or possible injury may result.

Visual Inspection			
A. Oil leaks	✓		
B. Switches	✓		
C. Drive Tire	✓		
D. Load Wheels	✓		
E. Caster Wheels	✓		
F. Control Linkage	✓		
Operational Tests			
A. Brakes			S
B. Brake Switch		r	
C. Horn	✓		
D. Steering	✓		
E. Speed Control	X		
F. Lift and Lower Control	✓		

CODE			
	✓	=	O.K.
O.K.	X	=	Adjust (Not P.M.)
Potential	r	=	Repair or Replace
Urgent	s	=	Requires Shop Repair

The nature of problems found during a PM should be noted in the “comments” portion of the check sheet. **Whenever a system or component is faulty or unsafe**, it must be noted on the check sheet, and reported to the designated authority at the conclusion of the P.M.

WARNING

Remove all jewelry before examining electrical components.

Group PS, Periodic Service

Visual Inspection

1. Inspect Battery Plug & Truck Receptacle

- Disconnect battery from truck.
- Inspect the spring loaded connectors in the truck battery receptacle and check the battery plug connectors. Severely burned connectors should be noted on the P.M. check sheet.

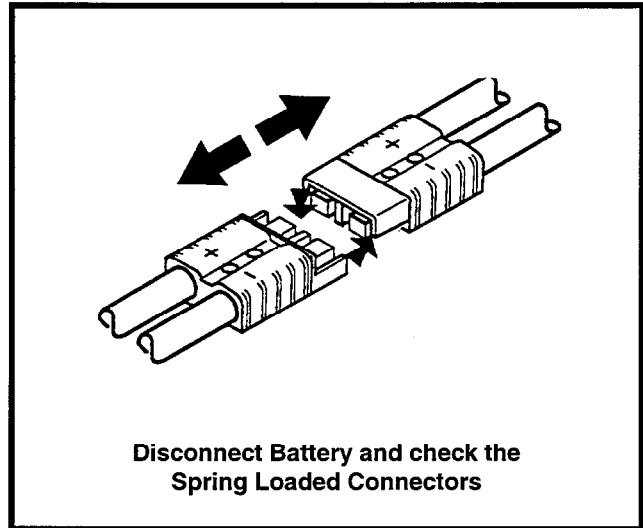

2. Inspect Battery Cover for damage

- The cover should not be dented. A badly dented Check Cover for Damage cover could short out across the battery cell connectors.
- The cover should be free to swing open and closed without binding.

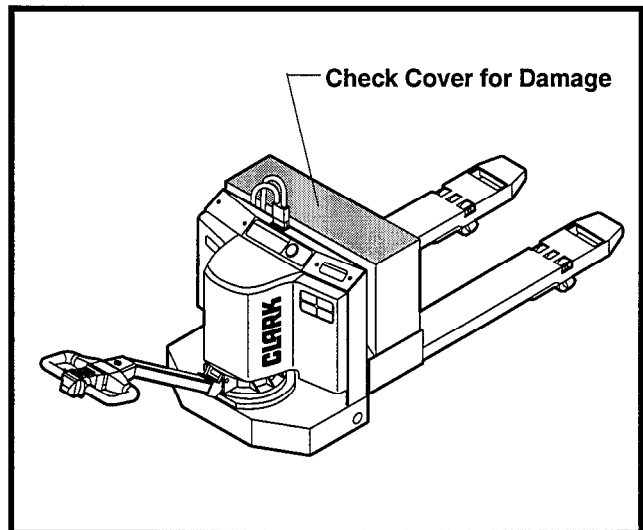

3. Inspect Pallet Forks for obvious damage

- Forks should not be bent or warped. If the forks are damaged, report condition to the designated authority.

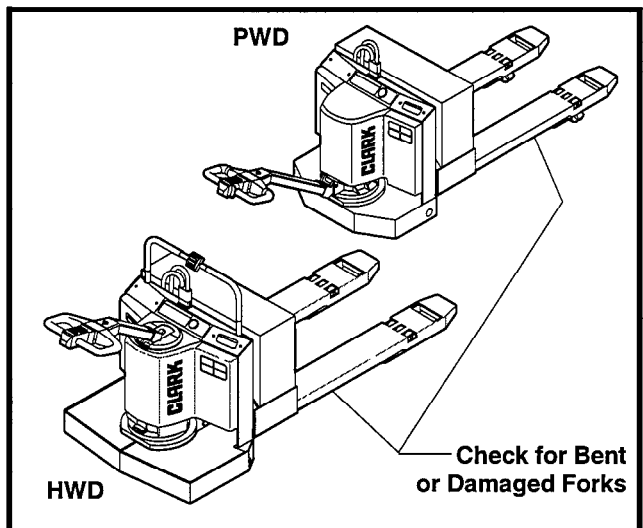

4. Rider Models

- Inspect Frame Components
- Check truck console, access cover and doors for damage.
- Inspect nameplates and decals for damage and to be sure they are not missing.

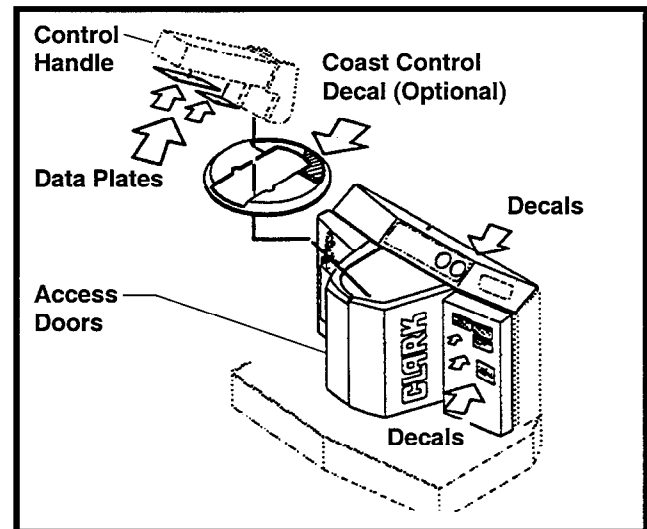

4A. Walkie Models

- Inspect Frame Components
- Check truck console, access cover and doors for damage.
- Inspect nameplates and decals for damage and to be sure they are not missing.

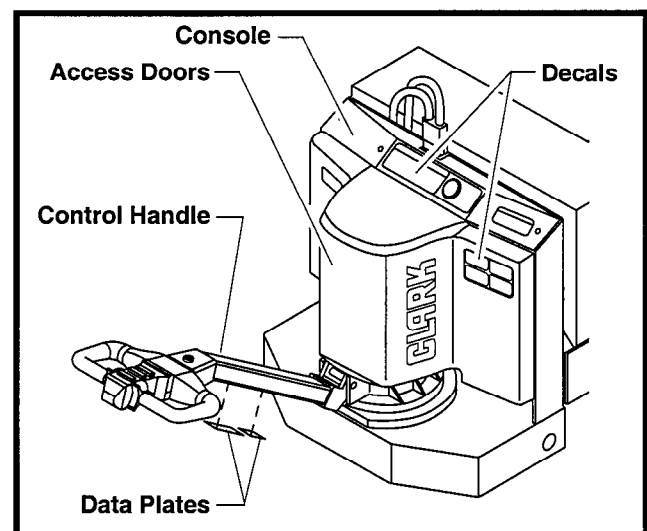

5. Check for obvious oil leaks

- Make a quick overall inspection for leakage. If an oil leak appears to be major, note condition on the check sheet for immediate attention. Minor leaks should be repaired during the P.M.

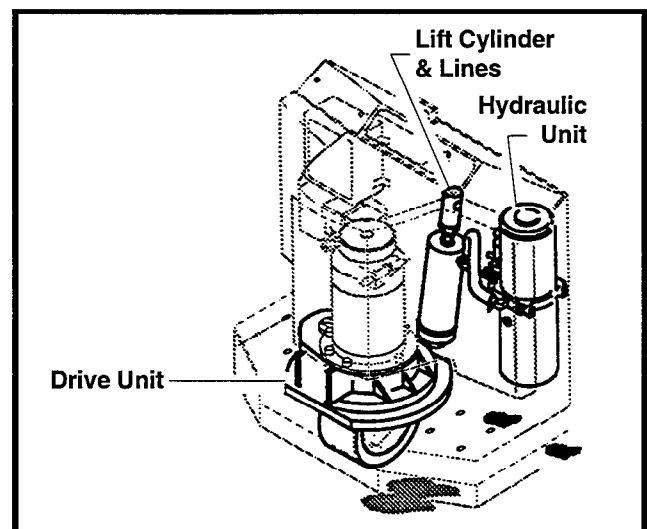

Group PS, Periodic Service

6. Inspect Tires & Wheels

- Check for obvious damage to tires on the load, caster and drive wheels.
- Look for excessive tire wear, cuts, breaks, chunking or bond failure between the tires and wheels. Note condition on the PM check sheet.
- Remove embedded objects from the tires.
- Be sure, wheel fasteners are secure and none are missing.
- Make certain grease fittings are not damaged or missing.

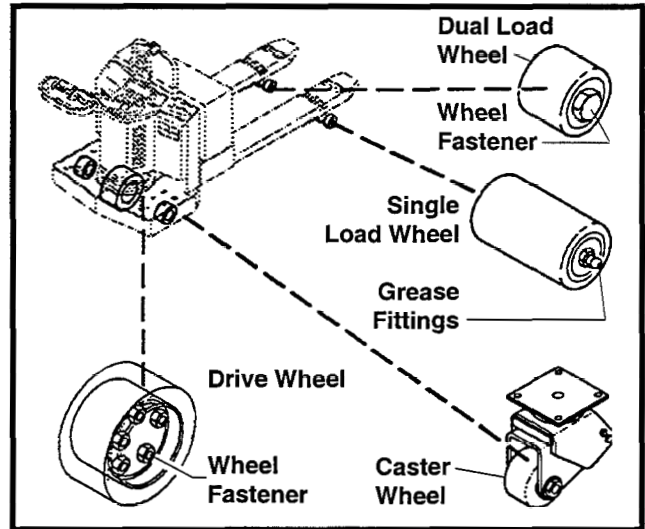

7. Expose Internal Components

- Open the access doors exposing the drive unit, brake, lift cylinder, hydraulic unit and SCR control. Each door hangs on a hinge pin. Lift the doors from their pins and set them to one side.

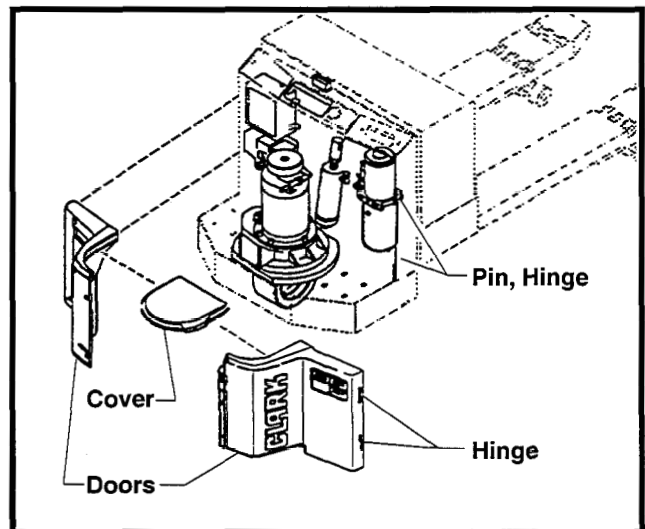

8. Connect Truck Battery

- Connect truck battery and check truck operation.

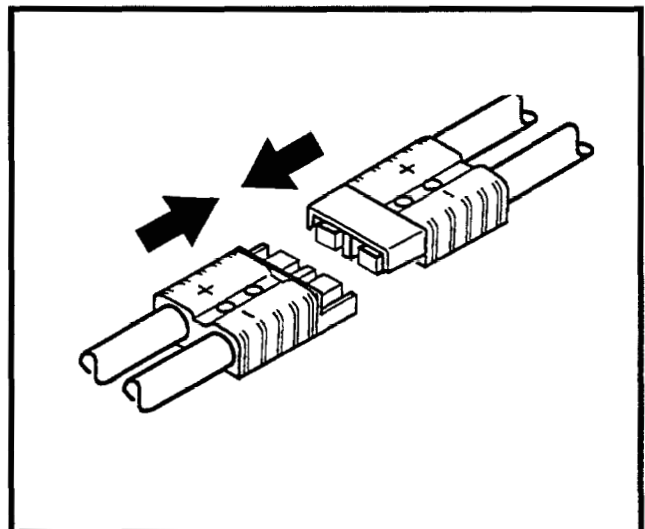

Operational Tests

9. All Models

- Turn the key switch on.

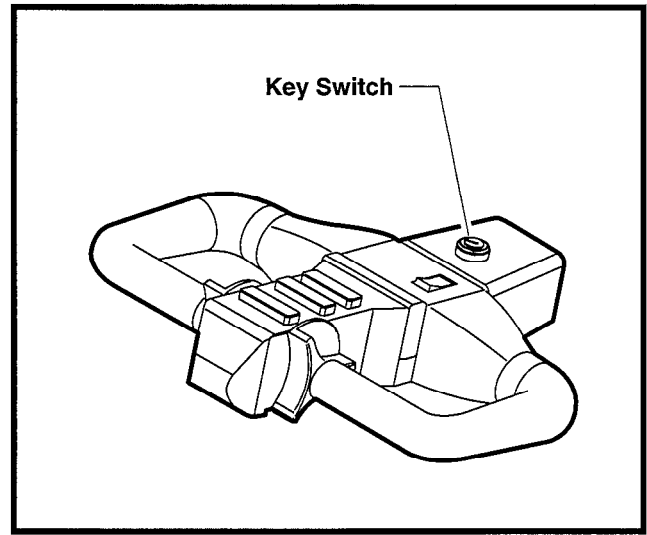

10. All Models

- Check the horn to be sure it operates.

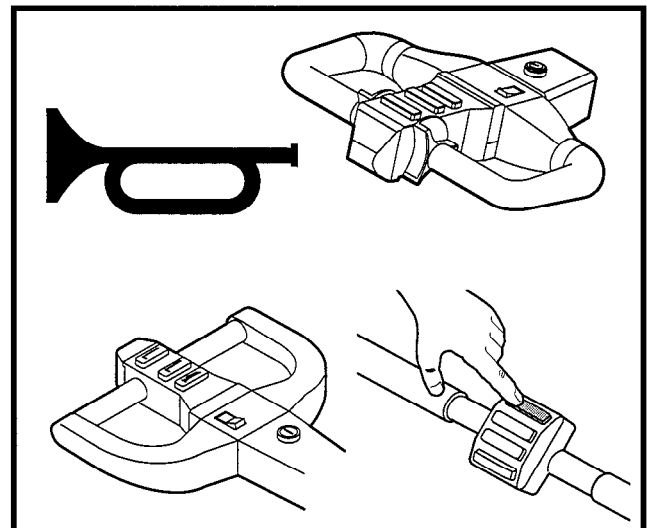

11. All Models

- Check the hour meter to be sure it operates.

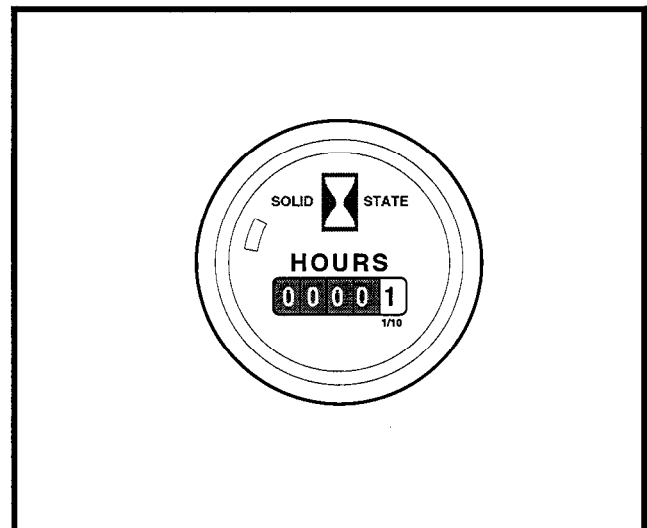

Group PS, Periodic Service

12. Check Steer Control Handle

- **Walkie Models**
- Be certain the control handle is mounted securely at the base of the drive unit.
- Make sure fasteners are tight and none are none missing.

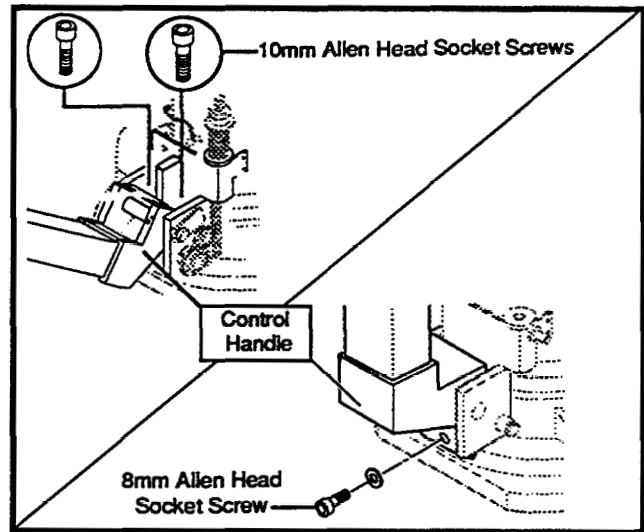

- **Rider Models**
- Check the mounting bracket to be sure it is securely mounted to the base of the drive unit.
- Make sure fasteners are tight and none are missing.

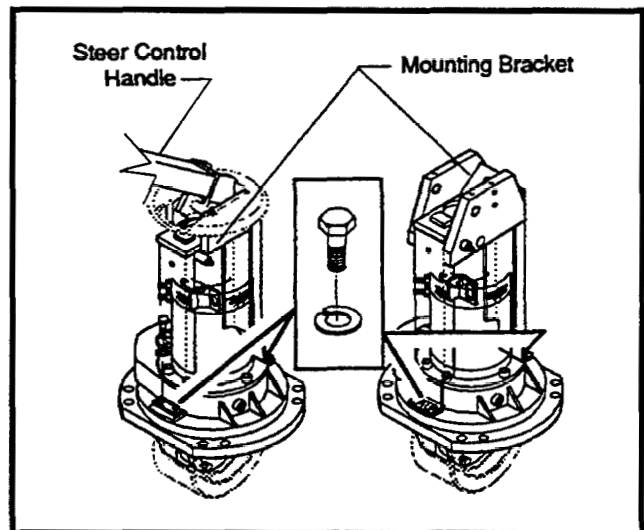

13. Check Steering

- Operate truck in reverse at a *slow rate of speed*. Move control handle through a full right and full left turn. Steering should be smooth without binding or hesitation.
- If there is binding, hard spots or movement appears to be stiff this indicates either lack of lubrication, misadjusted or damaged steering ring.
- Report condition on the P.M. check sheet.

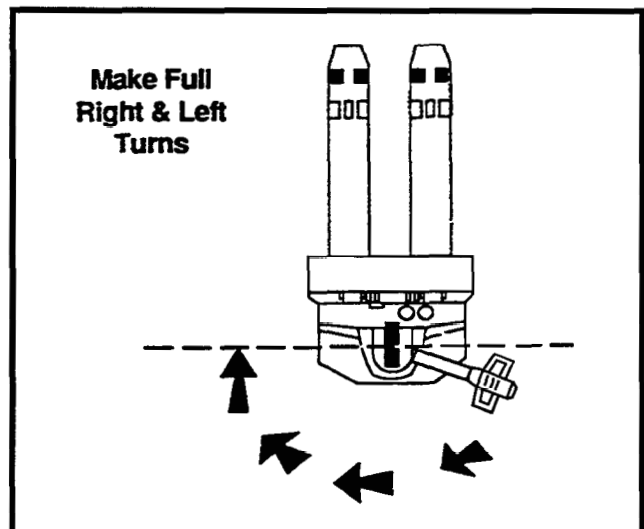

14. Check Brake Operation

- Move the steer control handle downward 10° degrees from vertical (brake on) position.
- Operate truck in reverse *at a slow rate of speed.*
- Slowly move control handle upward from the 10° travel (brake off) position.

As Control Handle approaches "Brake On" position:

1. The brake switch should operate shutting off the drive motor.
2. The brake should operate bringing the truck to a stop.

- Operate the truck in **forward** *at a slow rate of speed.*
- Slowly move control handle **upward** from the 10° (brake off) position. The brake should apply when handle reaches the full up (brake on) position.
- Now, check the brake at a high rate of speed in both forward and reverse directions.

14A. Next, check for proper brake operation by moving the handle **downward** from the 10° (brake off) position. The brake check should be done at Low and High Speeds, and in Forward & Reverse directions.

- If operation is not satisfactory, note condition on the P.M. check sheet. Report condition to designated authority for immediate attention.

NOTE

Plugging Control is normally used for gradual brake applications. **Braking with the steer control handle** is normally used in emergency situations and parking the truck.

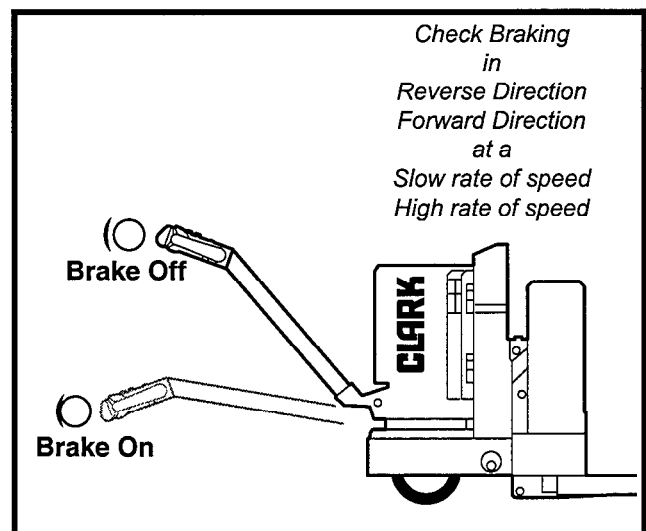
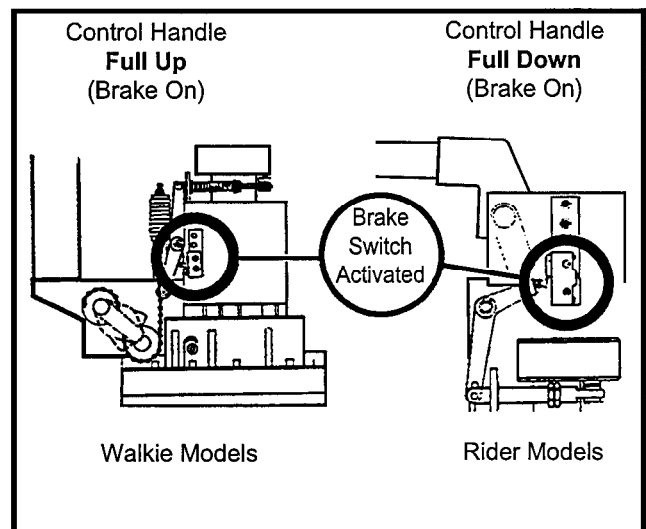
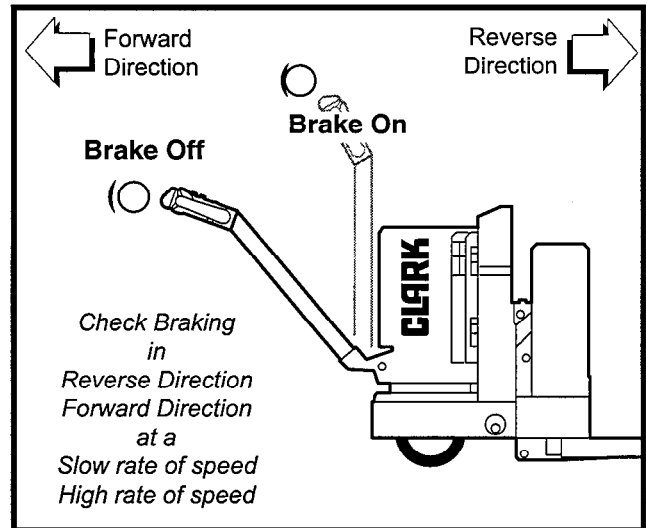



WARNING

After checking the coast control, be certain to return the coast control lever to the (brake on) position before resuming normal truck travel.

15. Check Coast Control Brake Operation (HWD MODELS)-(Optional)

- Move steer control handle past the full vertical position to partially compress a spring loaded rubber stop, see illustration.
- Now move the coast control out of the “brake on” position and into the “brake off” position.
- Release the steer control handle. The truck is now set up for a “coast mode” of operation allowing the operator to “jog” the truck with the F & R speed control.
- Slowly operate truck in a reverse direction of travel.
- Move steer control handle into vertical (brake on) position stopping truck.
- If brake operation is not satisfactory, note condition on P.M. check sheet. Report condition to designated authority for immediate attention.
- Return the coast control to the (brake on) position.

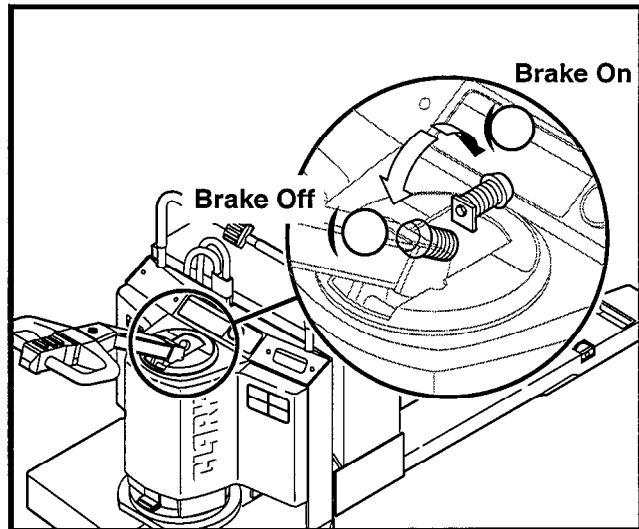

16. Check Travel Speeds

Check Acceleration

Check High Speed

- Drive truck in a straight line, looking in the direction of travel.
- Listen for any unusual drive train noise.
- Accelerate from low to high speed. Acceleration should be a smooth transition from creep through top speed. If transition is erratic, the *accelerator circuit* should be checked.

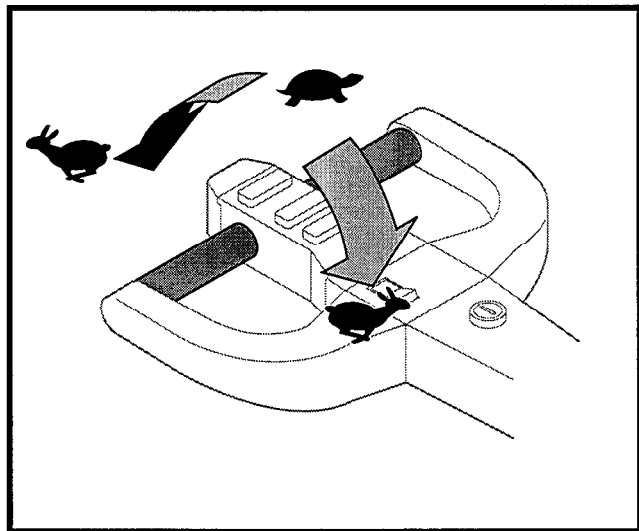

17. Check Hi-Speed Control

- Drive truck forward, in a straight line of travel.
- Fully rotate Directional Speed Control (1) until maximum (solid state control) speed is obtained
- Depress Hi-Speed Button (2). This transition should be smooth. If it is not, if it is erratic, jerky etc., the *accelerator* should be adjusted (Group 19). Note condition on the P.M. check sheet.

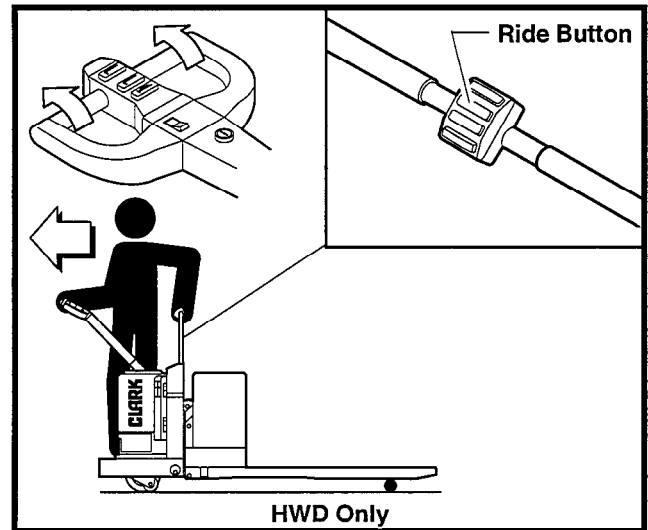

18. Override Control

- The override control is used to by-pass the emergency reversal switch circuit. This is desirable when the truck is operating in areas where plastic strip curtain doors (etc.) are used.

Example:

When moving a truck through this type door, pressure from the door strips can cause the emergency reversal switch to operate changing the direction of truck travel. By overriding the reversal switch, the truck can pass through the curtain door without miss hap.

- To simulate the above, operate truck in slow speed reverse. "Depress button to override" and then depress the reversal (belly) switch. Truck travel should remain in slow speed reverse. Note condition on the P.M. check sheet.

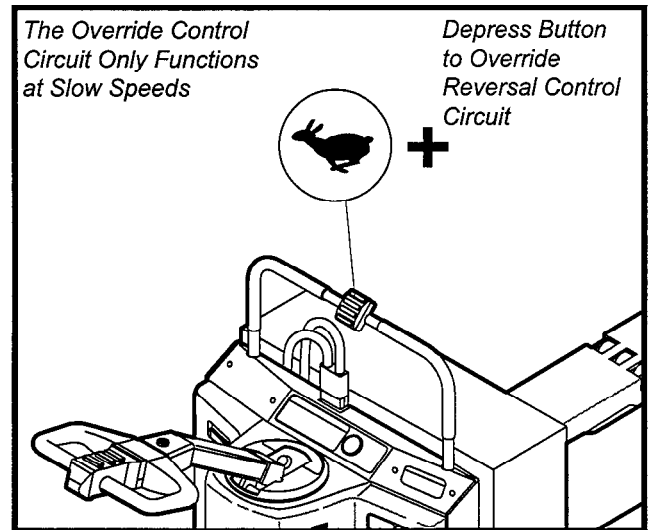

19. Elevate and Lower Pallet Forks

- Elevate pallet forks to maximum lift height. As the forks elevate, check to be sure they elevate smoothly and evenly without binding.
- Lower forks. Look for erratic motion as they lower. They should lower smoothly without hesitation.
- If there is erratic, jerking motion or binding of linkage as the forks elevate or lower, the lift linkage should be checked and adjusted (Group 35). Note condition on the P.M. check sheet.

Group PS, Periodic Service

20. Discharge the Capacitors

Be sure the battery is unplugged.

Discharge capacitors using a 100 ohm, 2 watt resistor connected between the Positive and Negative power terminals on the control. *Hold the resistor in place for 2 seconds before removing.*



CAUTION

Using a shorting device without a “resistor load” could cause damage to the control.



WARNING

Discharging the capacitors without using specified resistor could cause serious injury to yourself and bystanders.



WARNING

Prior to discharging the capacitors, make certain the cover is installed on the control panel power base.

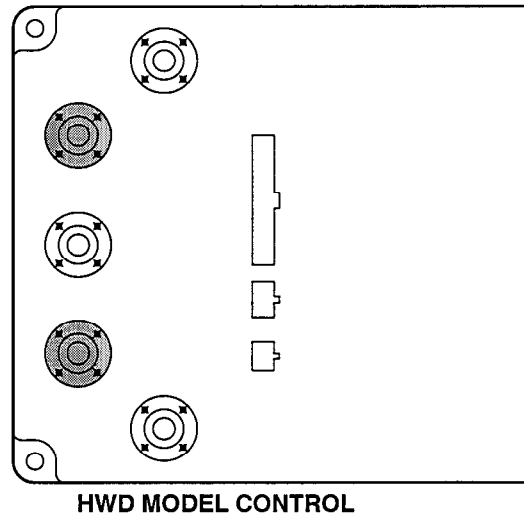
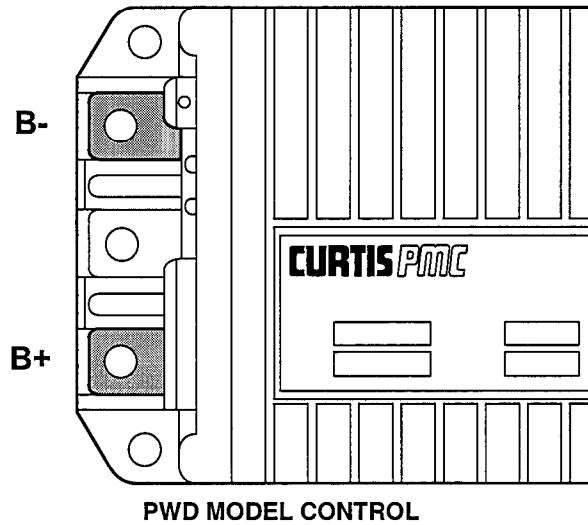

21. HWD Models

- **Inspect Operator Grab Rail**
- Check hand rail for security of mounting. Try moving hand rail fore and aft checking for loose connections and damage. The mounting bolts should be torqued to 100-120 lb. in.
- Make certain the switch housing is mounted securely and the switches are not damaged.
- Check wire harness condition. Check for loose connections and harness damage. Report condition on P.M. check sheet

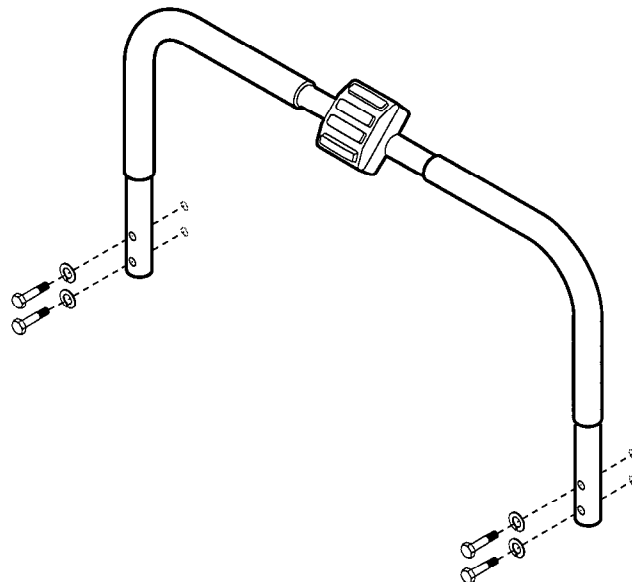

**Section 1.
Maintenance Schedule**

“Periodic Service” and “Planned Maintenance” 2
Determining Maintenance Intervals 2

“Periodic Service” and “Planned Maintenance”

The term “periodic service” includes all maintenance tasks that should be performed on a regularly scheduled basis.

The term “Planned Maintenance” indicates a formalized program of basic inspections, adjustments, and lubrications that the Clark service organization provides customers at a prescribed interval, usually 50-250 hours. The recommended basic “Planned Maintenance” procedure is given in Section 2 of this Group.

The current Section, “Maintenance Schedules,” specifies all maintenance tasks—including Planned Maintenance tasks—that should be performed periodically, and suggests intervals at which they should be performed.

Determining Maintenance Intervals

Time intervals on the charts on the next four pages and elsewhere in this manual relate to truck operating hours as recorded on the hourmeter, and are based on experience Clark has found to be convenient and suitable under **normal** operation. Standard operating condition classifications are:

Normal Operation: Eight-hour material handling, mostly in buildings or in clean, open air on clean, paved surfaces.

Severe Operation: Prolonged operating hours or constant usage.

Extreme Operation:

- In sandy or dusty locations, such as cement plants, lumber mills, and coal dust or stone crushing sites.
- High-temperature locations, such as steel mills and foundries.
- Sudden temperature changes, such as constant trips from buildings into the open air, or in refrigeration plants.

If the lift truck is used in *severe* or *extreme* operating conditions, the maintenance intervals should be shortened accordingly.

IMPORTANT

MAINTENANCE INTERVALS. If the lift truck is used in severe or extreme operating conditions, the maintenance intervals should be shortened accordingly.

Since the operating environments of lift trucks vary widely, the above descriptions are highly generalized and should be applied as actual conditions dictate.

P.M. CHECK SHEET

A special coding system on the P.M. Check Sheet allows truck condition to be reported with a minimum number of words. As the P.M. is performed, a check mark should be made in the appropriate box of the component being checked.

- (✓) indicates the particular truck component or system has been checked and is O.K.
- (x) indicates the component or system is in need of a minor adjustment or service (not part of the normal P.M.) that should be taken care of in the near future.
- (r) indicates there is a potential problem that could result in damage to a component or system and requires attention.
- (s) indicates the need for urgent repair or replacement of a component or system and the truck should be shut down as eminent damage or possible injury may result.

Visual Inspection			
A. Oil leaks	✓		
B. Switches	✓		
C. Drive Tire	✓		
D. Load Wheels	✓		
E. Caster Wheels	✓		
F. Control Linkage	✓		
Operational Tests			
A. Brakes			S
B. Brake Switch		r	
C. Horn	✓		
D. Steering	✓		
E. Speed Control	X		
F. Lift and Lower Control	✓		

CODE			
	✓	=	O.K.
O.K.	X	=	Adjust (Not P.M.)
Pontential	r	=	Repair or Replace
Urgent	s	=	Requires Shop Repair

The nature of problems found during a PM should be noted in the “comments” portion of the check sheet. **Whenever a system or component is faulty or unsafe**, it must be noted on the check sheet, and reported to the designated authority at the conclusion of the P.M.

WARNING

Remove all jewelry before examining electrical components.

Group PS, Periodic Service

Visual Inspection

1. Inspect Battery Plug & Truck Receptacle

- Disconnect battery from truck.
- Inspect the spring loaded connectors in the truck battery receptacle and check the battery plug connectors. Severely burned connectors should be noted on the P.M. check sheet.

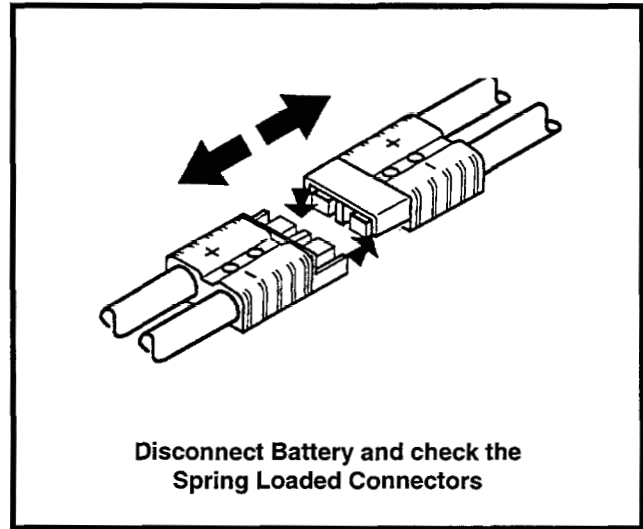

2. Inspect Battery Cover for damage

- The cover should not be dented. A badly dented Check Cover for Damage cover could short out across the battery cell connectors.
- The cover should be free to swing open and closed without binding.

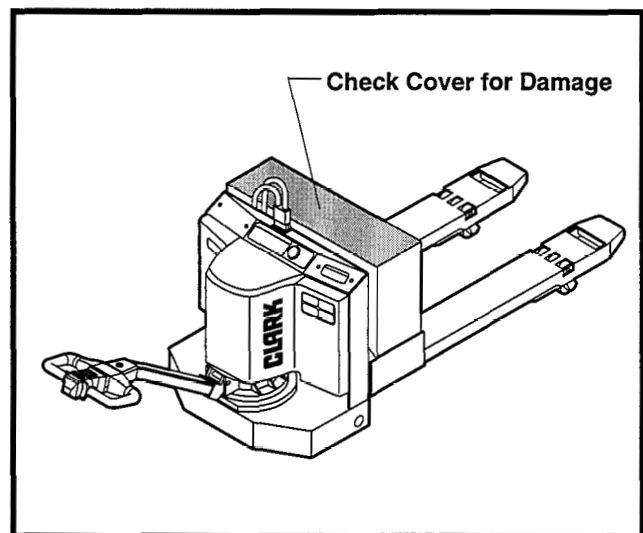

3. Inspect Pallet Forks for obvious damage

- Forks should not be bent or warped. If the forks are damaged, report condition to the designated authority.

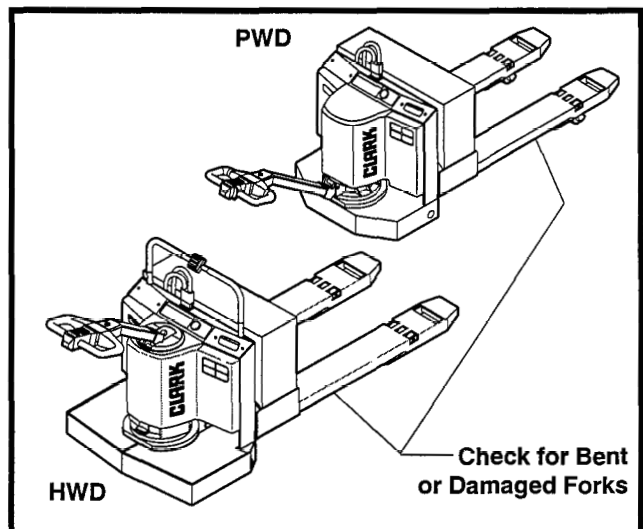

4. Rider Models

- Inspect Frame Components
- Check truck console, access cover and doors for damage.
- Inspect nameplates and decals for damage and to be sure they are not missing.

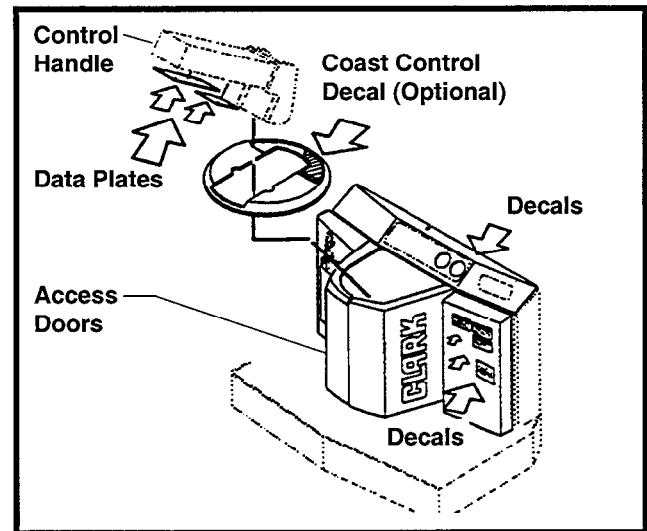

4A. Walkie Models

- Inspect Frame Components
- Check truck console, access cover and doors for damage.
- Inspect nameplates and decals for damage and to be sure they are not missing.

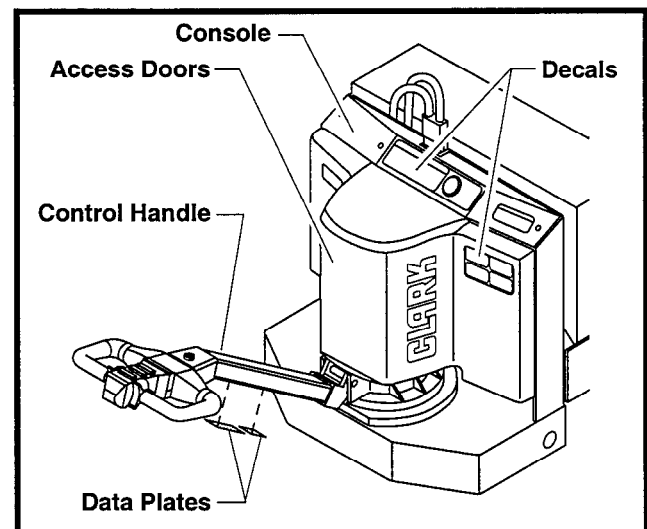

5. Check for obvious oil leaks

- Make a quick overall inspection for leakage. If an oil leak appears to be major, note condition on the check sheet for immediate attention. Minor leaks should be repaired during the P.M.

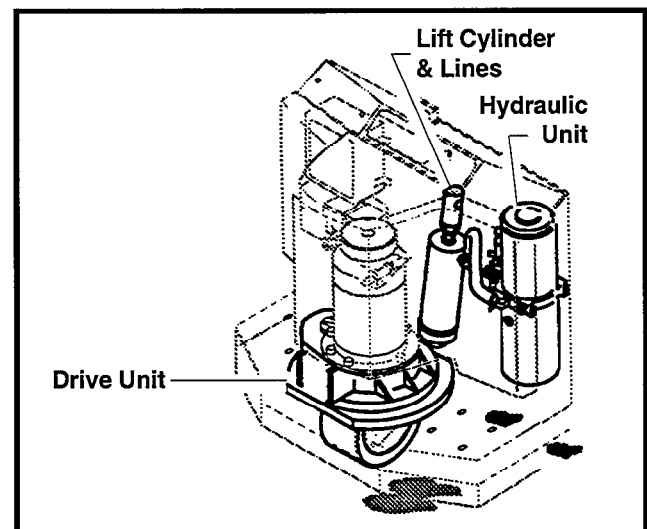

Group PS, Periodic Service

6. Inspect Tires & Wheels

- Check for obvious damage to tires on the load, caster and drive wheels.
- Look for excessive tire wear, cuts, breaks, chunking or bond failure between the tires and wheels. Note condition on the PM check sheet.
- Remove embedded objects from the tires.
- Be sure, wheel fasteners are secure and none are missing.
- Make certain grease fittings are not damaged or missing.

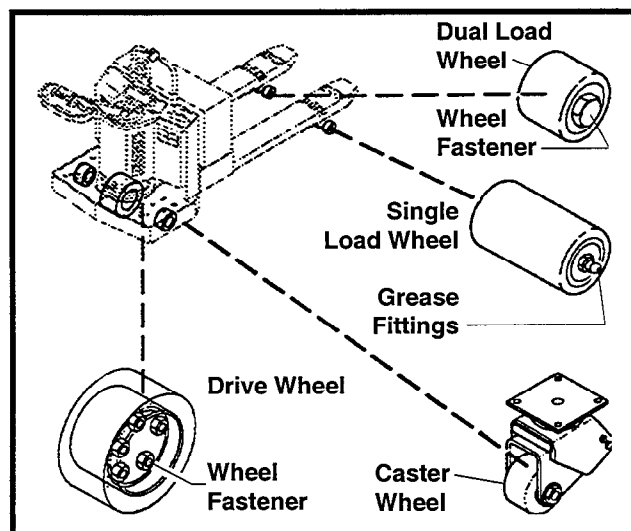

7. Expose Internal Components

- Open the access doors exposing the drive unit, brake, lift cylinder, hydraulic unit and SCR control. Each door hangs on a hinge pin. Lift the doors from their pins and set them to one side.

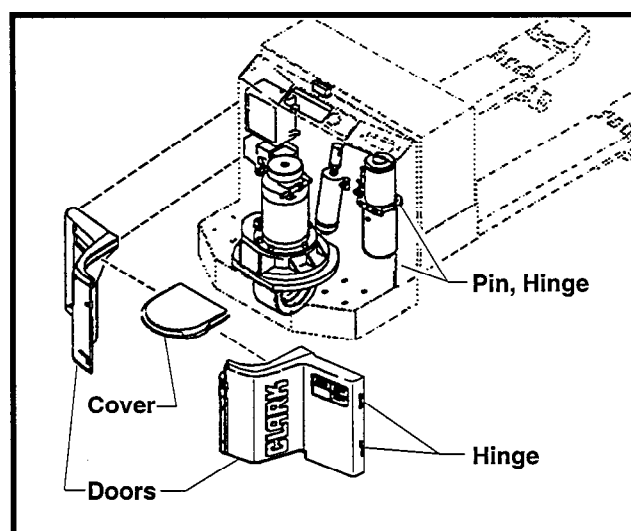

8. Connect Truck Battery

- Connect truck battery and check truck operation.

