

# SM-598S CGC, CGP, CDP 20-30 Shop Manual

VOLUME 1 OF 2, GROUPS 00 - 03

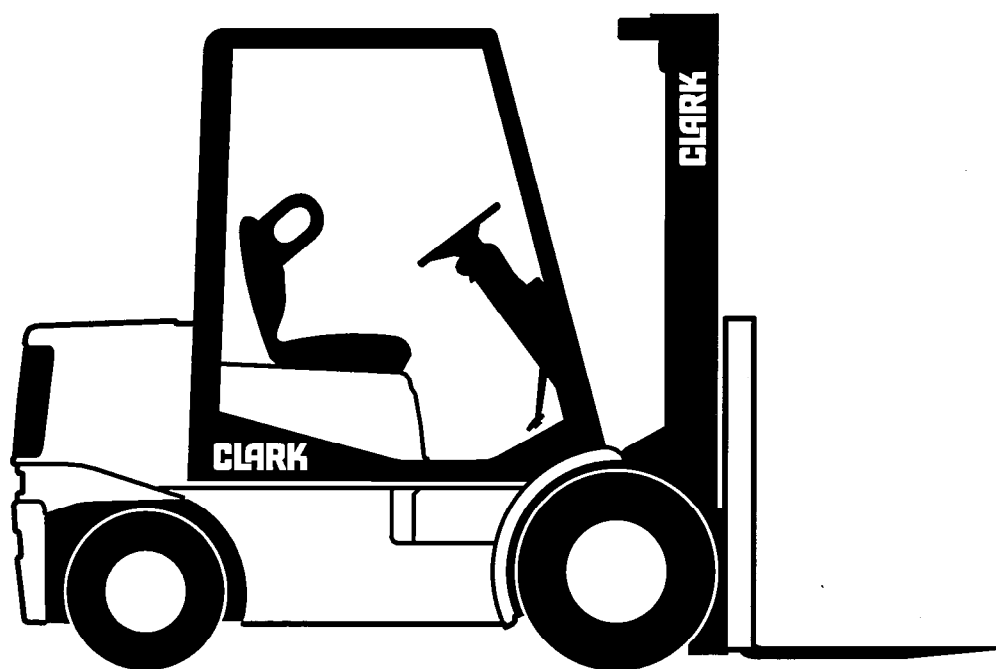

**CLARK** Technical  
Publications  
Lexington, KY  
40508

## Truck Models Covered by this Manual

This manual consists of a “base” module that pertains to all Genesis models and other modules that pertain only to specific models. Manuals shipped with the truck contain the base module and the modules specific to the purchased truck.

You may, however, purchase specific modules and expand your manual to fully cover multiple models. To do so, order the desired modules as you would any other Clark part.

## Arrangement and Use of this Manual

Clark arranges parts and service procedures by standardized *Groups*. In this manual, Groups are similar to “chapters.” Groups are listed in the indexes on the next page.

Each Group begins with a table of contents that shows the *Sections* contained within the Group. Lengthy Sections also begin with a table of contents.

Each Group and Section has an identifying name and number, or “ID.”

Each page also has a unique ID. The page ID consists of three numbers separated by hyphens. The three numbers represent the Group number, the Section number, and the page number. For example, “00-1-2” on the lower corner of the page indicates Group 00, Section 1, Page 2.

The Group number sometimes has a letter or letters added to it in parentheses if one or more variations of the Group exist. For example, if the truck has a standard transaxle, Group 06 is expressed as “06(S);” if the truck has a hydrostatic transmission, Group 06 is expressed as “06(H).”

You can quickly locate a specific point in the manual by using the headers and footers that appear on every Section page. The following illustration points out these areas.

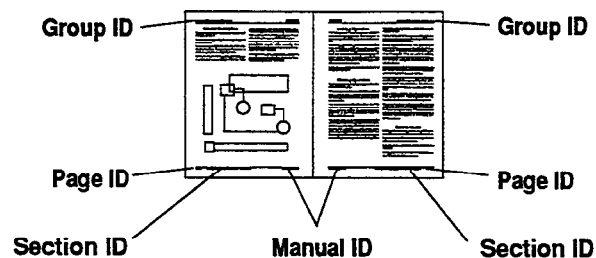

This manual is intended for the use of trained service personnel. Please read Group SA, “Safe Maintenance,” and the *Operator’s Manual* before working on or operating the truck.

## Contents of this Manual

### Group Index

Group SA. Safe Maintenance	Group 22. Wheels and Tires
Group PS. Periodic Service	Group 23. Brake System
Group 00. Engines	Group 25. Steering Column and Gear
Group 01. Cooling System	Group 26. Steer Axle
Group 02. Fuel System	Group 29. Hydraulic Pump, Sump, and Filters
Group 03. Air Induction System	Group 30. Hydraulic Control Valve/Lift Circuit
Group 06. Transmission	Group 32. Tilt Cylinders
Group 12. Ignition System	Group 34. Uprights
Group 13. Instrument Pod	Group 38. Counterweight, Sheet Metal, & Chassis
Group 14. Electrical System	Group 40. Specifications

### Alphabetical Index

(SEE NEXT PAGE)

### Pictorial Index

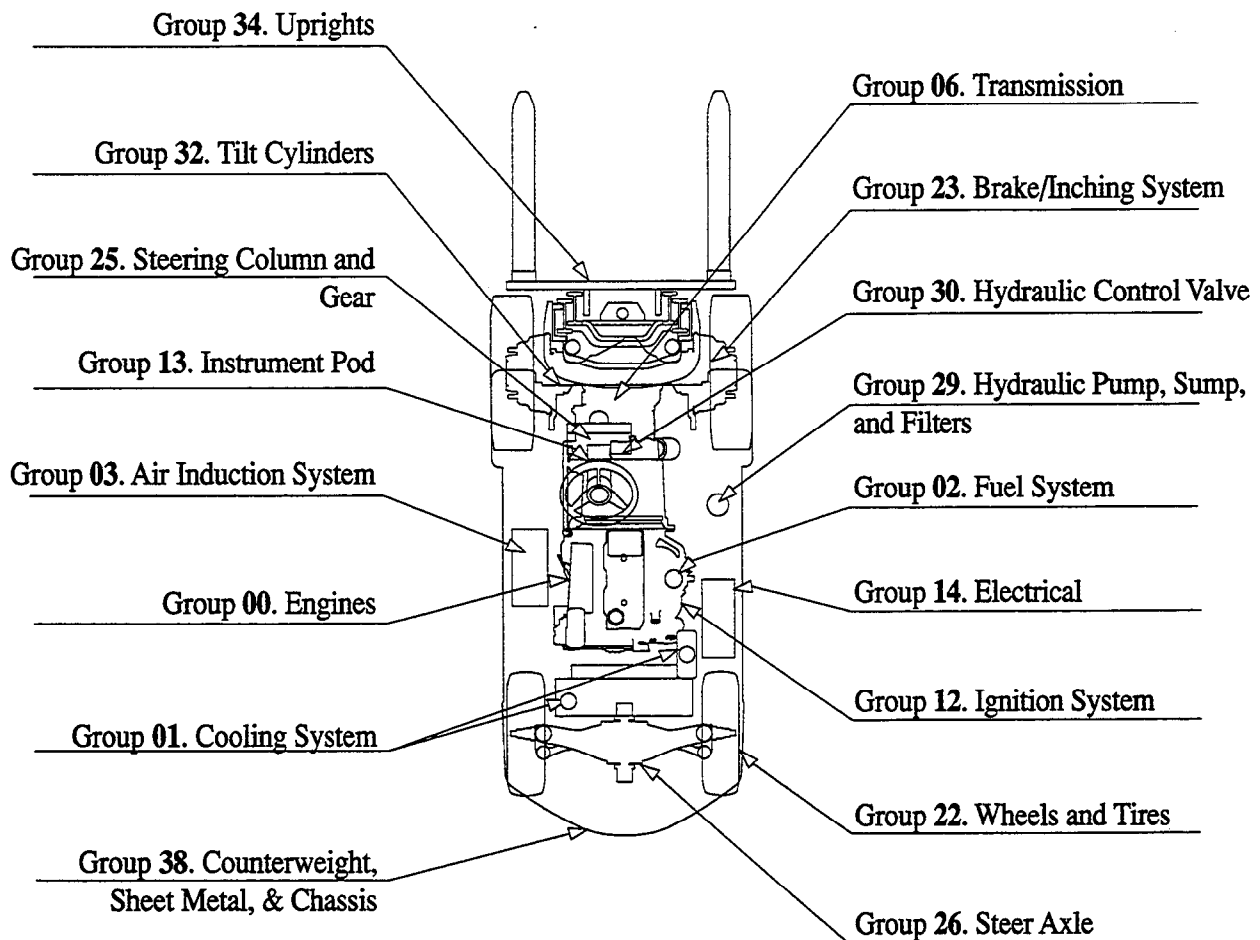

**GROUP SA**

**SAFE MAINTENANCE**

Safety ..... Section 1

Lifting, Jacking, and Blocking the Truck ..... Section 2

Towing..... Section 2

## Section 1. Safety

### Safety Signs and Messages

Safety signs and messages in this manual and on the lift truck provide instructions and identify specific areas where potential hazards exist and special precautions should be taken. Be sure you know and understand the meaning of these instructions, signs, and messages. Damage to the truck, death, or serious injury to you or other persons may result if these messages are not followed.

#### NOTE

**This message is used when special information, instructions or identification is required relating to procedures, equipment, tools, pressures, capacities, and other special data.**

#### IMPORTANT

**This message is used when special precautions should be taken to ensure a correct action or to avoid damage to, or malfunction of, the truck or a component.**

#### CAUTION

**This message is used as a reminder of safety hazards that can result in personal injury if proper precautions are not taken.**

#### WARNING

**This message is used when a hazard exists that can result in injury or death if proper precautions are not taken.**

#### DANGER

**This message is used when an extreme hazard exists that can result in injury or death or serious injury if proper precautions are not taken.**

The above terms have been adopted by Clark Material Handling Company. The same terms may be used in different context in service literature supplied directly or indirectly by vendors of truck components.

### Safe Maintenance Practices

The following instructions have been prepared from current industry and government safety standards applicable to industrial truck operation and maintenance. These recommended procedures specify conditions, methods, and accepted practices that aid in the safe maintenance of industrial trucks. They are listed here for the reference and safety of all workers during maintenance operations. Carefully read and understand these instructions and the specific maintenance procedures before attempting to do any repair work.

When in doubt of any maintenance procedure, please contact your local Clark dealer.

1. Powered industrial trucks can become hazardous if maintenance is neglected. Therefore, suitable maintenance facilities, trained personnel, and procedures must be provided.
2. Maintenance and inspection of all powered industrial trucks shall be done in conformance with the manufacturer's recommendations.
3. A scheduled planned maintenance, lubrication, and inspection program shall be followed.
4. Only trained and authorized personnel shall be permitted to maintain, repair, adjust, and inspect industrial trucks. Work should be performed in accordance with the manufacturer's specifications.
5. Properly ventilate work area, vent exhaust fumes, and keep shop clean and floor dry.
6. Avoid fire hazards and have fire protection equipment present in the work area. Do not use an open flame to check for level or leakage of fuel, electrolyte, or coolant. Do not use open pans of fuel or flammable cleaning fluids for cleaning parts.
7. Before starting work on truck:
  - a. Raise drive wheels off of floor or disconnect power source and use blocks or other positive truck positioning devices.
  - b. Disconnect battery before working on the electrical system.
8. Before working on engine fuel system of gasoline- or diesel-powered trucks, be sure the fuel shut-off valve is closed.

9. Operation of the truck to check performance must be conducted in an authorized, safe, clear area.
10. Before starting to drive truck:
  - a. Be in operating position.
  - b. Be sure parking brake is engaged.
  - c. Put direction control in neutral.
  - d. Start engine.
  - e. Check functioning of direction and speed controls, steering, brakes, warning devices, and any load handling attachments.
11. Before leaving truck
  - a. Stop truck.
  - b. Put directional control in neutral.
  - c. Apply the parking brake.
  - d. Stop the engine by turning off the ignition circuit.
  - e. Put blocks at the wheels if truck is on an incline.
12. Brakes, steering mechanisms, control mechanisms, warning devices, lights, governors, guards, safety devices, and frame members must be carefully and regularly inspected and maintained in a safe operating condition.
13. Special trucks or devices designed and approved for hazardous area operation must receive special attention to ensure that maintenance preserves the original, approved, safe-operating features.
14. Fuel systems must be checked for leaks and condition of parts. Extra special consideration must be given in the case of a leak in the fuel system. Action must be taken to prevent the use of the truck until the leak has been corrected.
15. The truck manufacturer's capacity, operation, and maintenance instruction plates, tags, or decals must be maintained in legible condition.
16. Batteries, motors, controllers, limit switches, protective devices, electrical conductors, and connections must be inspected and maintained in conformance with good practice. Special attention must be paid to the condition of electrical insulation.
17. To avoid injury to personnel or damage to the equipment, consult the manufacturer's procedures in replacing contacts on any battery connection.
18. Industrial trucks must be kept in a clean condition to minimize fire hazards and help in the detection of loose or defective parts.
19. Modifications and additions that affect capacity and safe truck operation must not be done without the manufacturer's prior written approval. Capacity, operation and maintenance instruction plates, tags, or decals must be changed accordingly. This is an OSHA requirement.
20. Care must be taken to assure that all replacement parts, including tires, are interchangeable with the original parts and of a quality at least equal to that provided in the original equipment. Parts, including tires, are to be installed per the manufacturer's procedures. Always use genuine CLARK or CLARK-approved parts.
21. Use special care when removing heavy components from the truck, such as counterweight, seat deck, upright, etc. Be sure that lifting and handling equipment is of the correct capacity and in good condition. Also, this removal may upset the stability of the truck. The frame must always be safely blocked for major component removal.

### NOTE

**You should also be familiar with additional operating and maintenance safety instructions contained in the following publications:**

ANSI/ASME B56.1 - 1988 Operator Control-Industrial Tow Tractors (Safety Standard For Powered Industrial Trucks). Published by: Society of Mechanical Engineers, United Engineering Center, 345 E. 47th Street, New York, NY 10017.

NFPA 505-1982: Fire Safety Standard for Powered Industrial Trucks: Type Designations, Areas of Use, Maintenance and Operation. Available from: National Fire Protection Assoc., Inc., Batterymarch Park, Quincy, MA 02269.

General Industrial Standards, OSHA 2206: OSHA Safety and Health Standards (29 CFR 1910), Subpart N-Materials Handling and Storage, Section 1910.178 Powered Industrial Trucks. For sale by: Superintendent of Documents, U.S. Government Printing Office, Washington, DC 20402.

## Section 2.

### Lifting, Jacking, and Blocking

Safe Parking .....	2
Lifting, Jacking, and Blocking Points .....	2
Raising Drive Wheels Off Floor .....	2
Raising Truck with A Hoist .....	3
Blocking the Upright in Raised Position .....	4
Raising Rear of Truck .....	4
Raising Entire Truck .....	5
Shipping Tie-Down Instructions .....	6

 **WARNING**

Lifting or jacking any large piece of equipment such as your fork truck presents obvious hazards. It must be done with great care and forethought. Consult the truck weight tabulations in Group 40, "Specifications" to ensure that your lifting equipment is of adequate capacity.

### Safe Parking

Before working on truck:

1. Park truck on a hard, level, and solid surface, such as a concrete floor with no gaps or breaks.
2. Put upright in vertical position and fully lower the forks or attachment.
3. Put all controls in neutral. Turn key switch OFF and remove key.
4. Apply the parking brake and block the wheels.

**! WARNING**

Defective equipment can cause accidents. All tools and lifting equipment must be in good condition, meet the load capacity requirements and have OSHA labels when required. Tools with defects can have failures causing severe injury or death.

### Lifting, Blocking, and Jacking Points

Use the following illustration to locate general lifting, blocking, and jacking points on the truck. Read the procedures for raising, blocking, or jacking specific components of the truck to make sure you understand the correct, safe procedures.

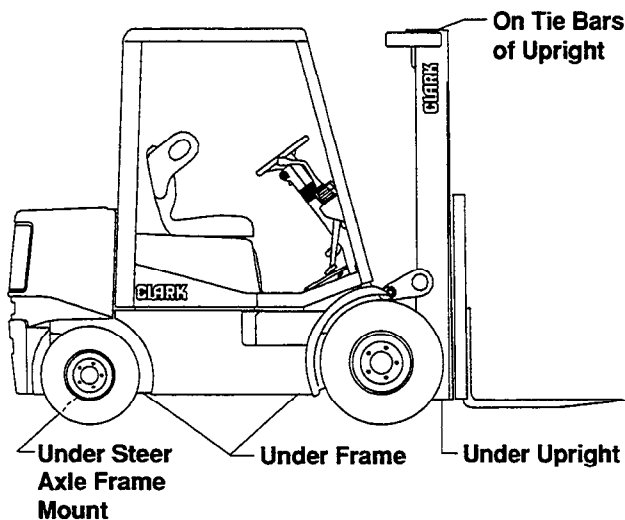

**! WARNING**

Do not attempt to lift the truck by the overhead guard or the counterweight. Severe injury may result and the truck can be damaged.

### Raising Drive Wheels Off Floor

This procedure uses the upright as a lever to lift the drive wheels off the floor and prevent accidents due to inadvertent powering of the drive wheels.

1. Park truck safely as described in "Safe Parking." Block steer wheels.
2. Be sure upright trunnion bolts are tight. Bolt torques must be 75-80 N•m (55-59 ft-lb).
3. Start the engine. Tilt the upright fully back. Adjust upright height as necessary to put blocking underneath the lower end of the upright.
4. Put a solid 100 x 100 mm (4 x 4 in) hardwood block under the front section of each upright rail. Put a 3-6 mm (.125-.250 in) steel plate on top of each block.

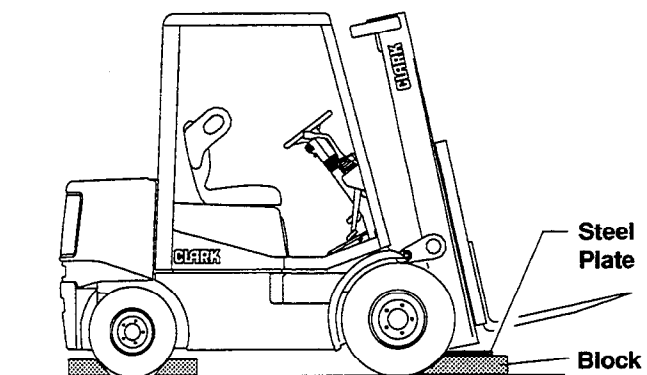

5. Tilt upright fully forward. This raises the drive wheels off the floor. Release the tilt control lever and turn engine OFF.

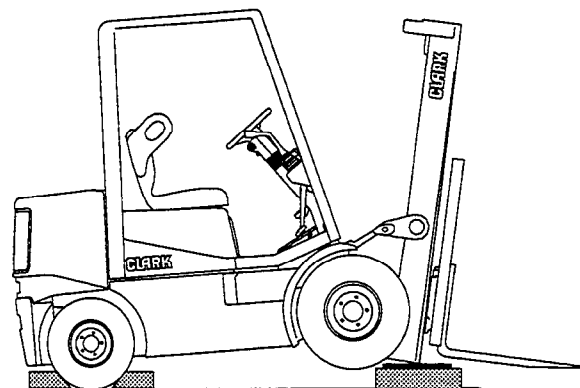



6. Insert blocking under the frame behind the drive wheels or slip wheel cradles under the drive wheels. If using blocking, check for safe clearance between drive wheels and floor and blocks.

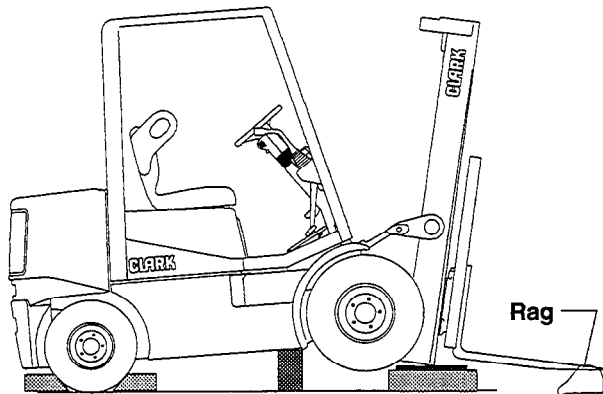

### NOTE

When forks are raised as in illustration above, use shop rags, paper, or bright tape on fork tips to signal the danger of tripping.

7. Check for stable condition of the truck. Be sure that the blocks are located securely under the truck frame before operating the drive or working on truck.
8. Lower the drive wheels to the floor and remove the blocks by reversing the above procedure.

### Raising Truck with A Hoist

When suitable equipment is available, the front of the truck may be raised by means of a hoist, with wheel cradles placed under the wheels or blocking placed under the frame.

### ! CAUTION

When lifting the front of the truck watch truck for signs of lateral instability. It may tip sideways. You may have to support or guide the side of the truck or overhead guard to prevent tipping.

1. Park truck safely as described in "Safe Parking." Block rear steer wheels.
2. Check trunnion bolts to make sure they are tightened to correct torque. Bolt torques must be 75-80 N•m (55-59 ft-lb).

3. To raise the front of the truck using the upright, spread two chains on the outer rail tiebar of the upright.

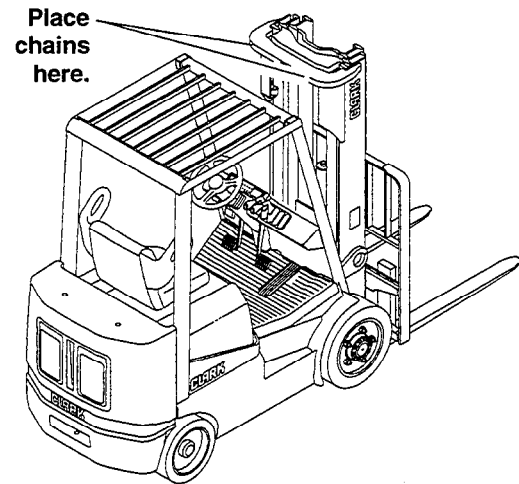

### ! WARNING

Chain and hoist used to lift truck should be checked to make sure they are of safe lifting capacity. See the truck data plate for information.

4. Slowly lift truck and lower drive wheels onto the cradles or place blocking under frame prop points.

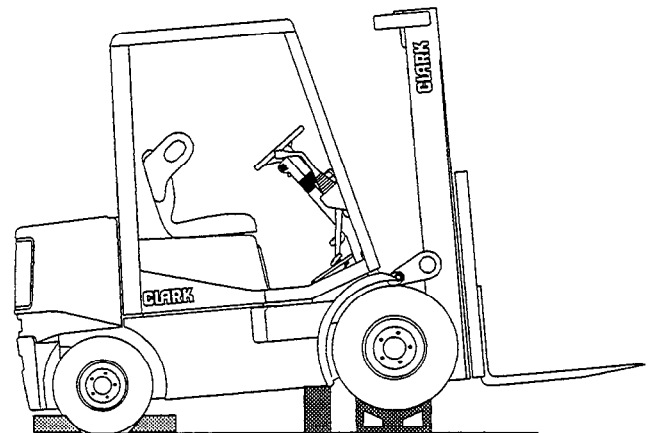

5. When maintenance work is completed, lower the truck to the floor by reversing the lifting procedure. Check to be sure no tools or equipment are under the truck or wheels.

### Blocking the Upright In Raised Position

This procedure is used to safely provide clearance for access from the front of truck to components on or near the drive axle. Illustrations show upright with forks removed however, fork removal is not necessary

1. Park truck safely as described in "Safe Parking."
2. Put blocks in front of and behind drive wheels.
3. Put wooden support blocks conveniently near upright rails before raising the upright. Use two 100 x 100 mm (4 x 4 in) hardwood blocks or equal, of about 300 x 300 mm (12 in) and 600 x 600 mm (24 in) length.

**NOTE**

**For standard uprights, block may need length cut to suit. For triple stage uprights, the carriage may be blocked up, as shown.**

4. Start engine and raise the upright carriage.
5. Hold the taller block against inner rail and lower the upright until carriage rests on block.

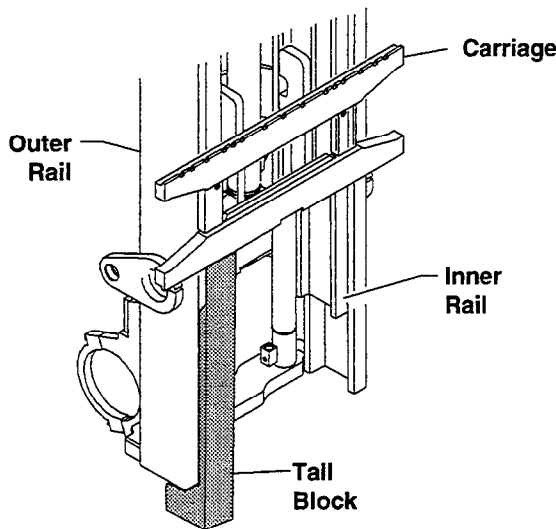

6. Hold the shorter block against the outer rail and lower the upright until inner rail rests on the block.

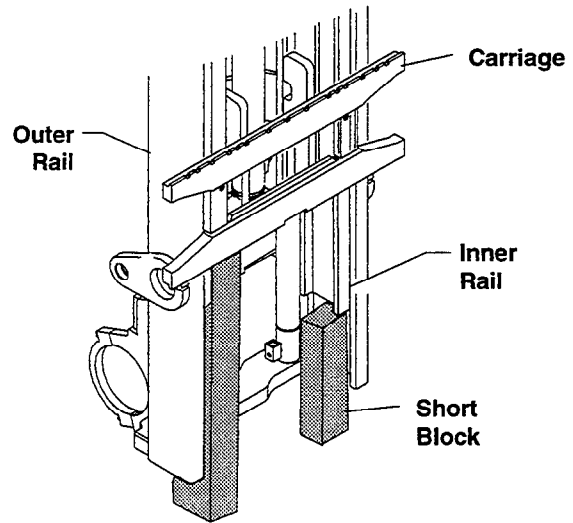

7. Reverse the procedure to remove blocking.

### Raising Rear of Truck

The truck may be raised at the rear by jacking and blocking under the center of the frame member at either the front or rear steer axle mounting, or under the center section of the steer axle.

Refer to truck data plate for truck weights.

**WARNING**

**An incorrectly installed counterweight can move or fall unexpectedly. Never lift or block a truck using the counterweight. Failure to follow procedures outlined in this manual can result in injury or death.**

1. Park truck safely as described in "Safe Parking." Put blocks at front and rear of drive wheels.

2. Put a floor jack under the steer axle mounting frame member, centered between the two wheels.

**! WARNING**

Never lift the truck by the counterweight.

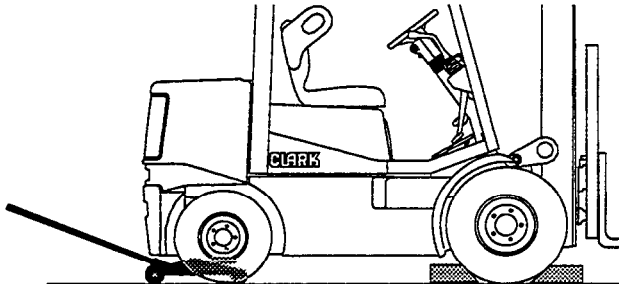

**NOTE**

If there is insufficient clearance under frame for your jack, the truck may first be driven onto shims, such as 25 x 150 x 300 mm (1 x 6 x 12 in) pieces of board, to increase the truck frame underclearance.

3. Raise the truck only as high as necessary to perform the maintenance work.
4. Put blocks at both sides of the truck, fully under the frame main side structure. Put the blocks in front of but close to the counterweight and steer wheels for best truck stability.

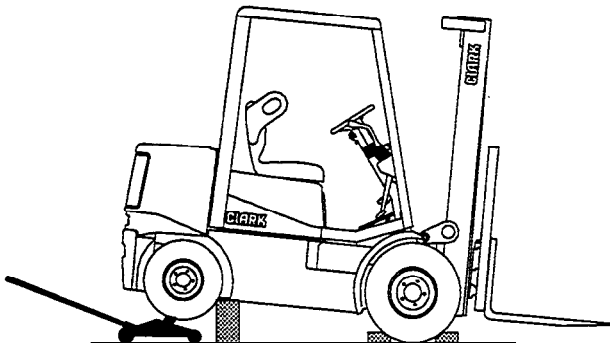

Put equal blocks under each side of the truck to provide a level working position.

5. Lower the truck onto the blocks and remove the jack.

**! CAUTION**

Before performing any maintenance, check the truck for stability on the blocks.

6. When maintenance work is completed, lower the rear of truck to the floor by reversing the above procedure and lowering each side of the truck 50 mm (2 in) at a time:

- Put jack under frame and raise truck.
- Carefully remove blocks and lower truck.
- Remove jack and blocks from drive wheels.

## Raising Entire Truck

Refer to truck data plate for truck weights.

1. Park truck safely as described in "Safe Parking." Lower upright fully.
2. If necessary, drive truck onto boards to increase underclearance.

**! WARNING**

**SIDE-TO-SIDE TIPOVER.** When jacking side of truck, be sure upright is lowered fully and do not raise one side of the truck more than about 50 mm (2 in) higher than the other, to avoid tipping truck over laterally.

**END-TO-END TIPOVER.** If the upright and transaxle are removed while the truck is blocked up, the truck will tip backwards due to the heavy counterweight. Both upright and counterweight must be removed before attempting to raise the truck for transaxle removal. The back of the truck must be supported by blocking under the steer axle to prevent movement.

The reverse is also true. If the counterweight is removed while the truck is up on blocks, the weight of the upright and transaxle will cause the truck to tip on the front blocks and fall forward.

3. Put the jack under side frame near the center of the truck.

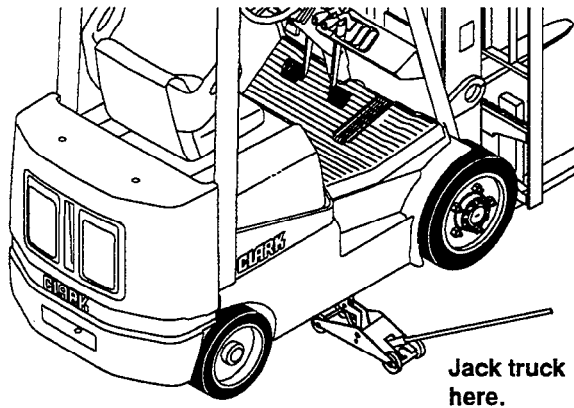

**IMPORTANT**

Be sure to put the jack squarely and fully under the main side structure of the frame. Do not put the jack under the outer covers which enclose the fuel and hydraulic sump tanks.

4. Carefully raise the truck one side at a time, only as high as necessary to do the maintenance work and not more than a maximum of 150 mm (6 in) total.
5. Put blocks under the side frame, at each side of the jack. Spread the blocks close to the steer and drive wheels for maximum stability.

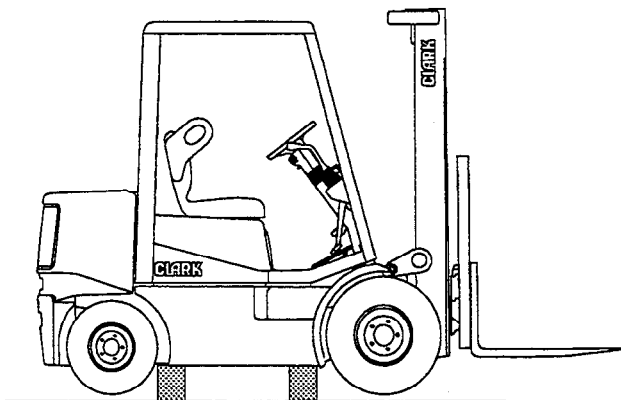

6. If using one jack, lower the truck onto the blocks and move the jack to the opposite side. Repeat the lifting procedure.
7. Put the same size blocks under each side of the truck so it will be level.

**CAUTION**

Before performing any maintenance work, check the truck for stable condition on the blocking.

8. When maintenance work is completed, lower the entire truck to the floor by reversing the lifting procedure. Lower the truck one side at a time, while carefully removing the blocks. Check to be sure no tools or equipment are under the truck or wheels.

**NOTE**

Depending on jack height, shims under the tires may be needed for clearance to allow removal of jack.

**Shipping Tie-Down Instructions**

1. Front of Truck
  - a. With Upright and Carriage Installed
    - Lower the carriage fully.
    - Put a tie down (e.g., chain) between the carriage fork bars.

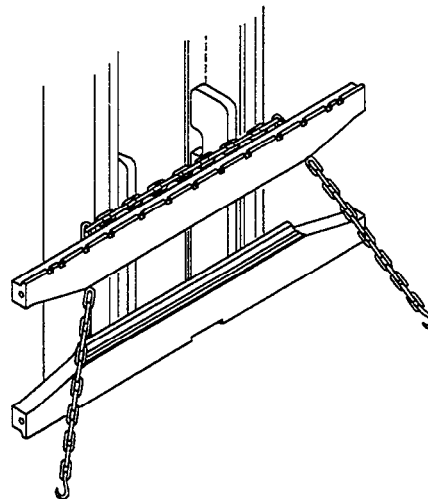

- b. Without an Upright and Carriage Installed
    - Put a chain across the truck floor plate. Protect truck from chain damage by using covered chain or protective material under the chain at contact points.

2. Rear of Truck
  - Attach the tie down to pocket in bottom of counterweight.

### Section 3.

### Towing

If your truck is disabled but can be moved freely on its own wheels without further damage, use the following procedures to tow the truck safely to a repair area.

#### **! WARNING**

**It is important for your safety and to the care of your lift truck to use the proper equipment and carefully follow these recommendations for safe towing.**

**Do not tow a lift truck if there is a problem with the brakes or tires, or if the steering cannot be operated.**

**Do not tow the disabled truck up or down ramps or steep inclines.**

**Do not attempt to tow the disabled truck if traction or weather conditions are poor.**

1. Be sure to apply the parking brake or block the drive wheels on the disabled truck while working around it.
2. When possible, raise the carriage (forks) on the disabled truck 300 mm (12 in) from the floor or ground. Secure the carriage on the upright with a chain.
3. Use a truck for towing that is of equal or larger capacity than the disabled truck. Carry a partial load on the tow truck for improved traction.

4. Check that the counterweight bolts on both trucks are in place and properly torqued to 340-380 N•m (250-280 ft-lb). These bolts are made of special, high-tensile steel and are not commercially available. When necessary, replace these bolts only with a genuine Clark replacement part.
5. Use an approved, solid metal tow bar with towing couplers that connect to the towing pins in the counterweights.

#### **NOTE**

**DOT-approved towing equipment is available from your Clark dealer.**

6. Release the parking brake on the towed vehicle. Place directional control lever in neutral.
7. Tow the disabled truck backwards. An operator must be on the disabled truck.

#### **! CAUTION**

**The power steering will not operate on the disabled truck when the engine is not running. The steering handwheel will be difficult to turn.**

8. Tow the truck slowly. Careful towing is necessary to prevent injury to personnel or damage to the disabled truck. The truck should be towed at a speed of less than 8 kph (5 mph, or a moderate walking speed) with a driver in place and steering the disabled truck.

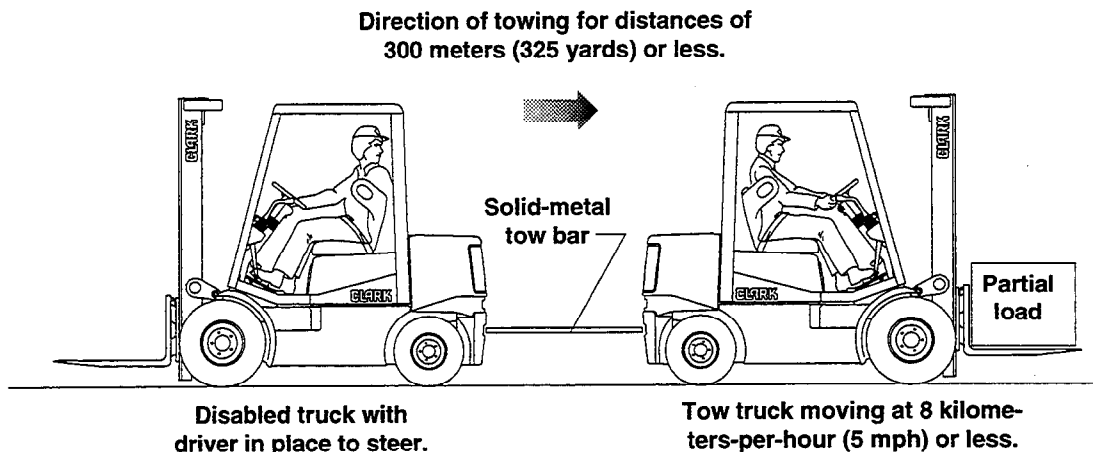

**IMPORTANT**

**Do not lift the disabled truck or any wheels off the floor while the truck is being towed.**

- 9. Park the disabled truck in authorized areas only. Fully lower the forks on the floor, leave the directional control in neutral, turn the ignition switch to OFF, and engage the parking brake. Remove the ignition key and, when necessary, block the wheels to prevent the truck from rolling.

**! WARNING**

**Always engage the parking brake when parking a lift truck. The truck can roll and cause injury or death to personnel near it.**

LIFT TRUCK PARKING

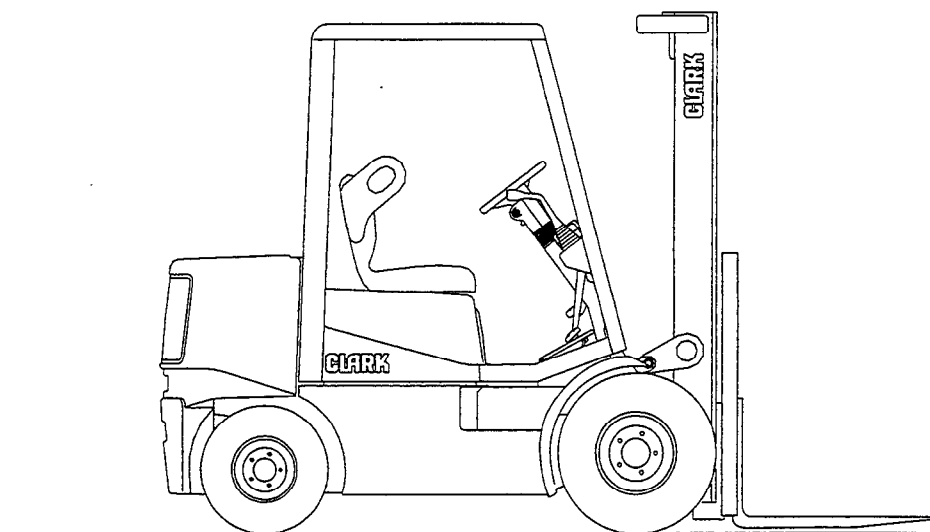

## **PERIODIC SERVICE**

<b>Maintenance Schedules .....</b>	<b>Section 1</b>
<b>The Planned Maintenance Program .....</b>	<b>Section 2</b>
<b>The PM Inspection Form .....</b>	<b>Section 3</b>

## Section 1. Maintenance Schedules

### “Periodic Service” and “Planned Maintenance”

The term “periodic service” includes all maintenance tasks that should be performed on a regularly scheduled basis.

The term “Planned Maintenance” indicates a formalized program of basic inspections, adjustments, and lubrications that the Clark service organization provides customers at a prescribed interval, usually 50-250 hours. The recommended basic “Planned Maintenance” procedure is given in Section 2 of this Group.

The current Section, “Maintenance Schedules,” specifies all maintenance tasks—including Planned Maintenance tasks—that should be performed periodically, and suggests intervals at which they should be performed.

### Determining Maintenance Intervals

Time intervals on the charts on the next four pages and elsewhere in this manual relate to truck operating hours as recorded on the hourmeter, and are based on experience Clark has found to be convenient and suitable under **normal** operation. Standard operating condition classifications are:

**Normal Operation:** Eight-hour material handling, mostly in buildings or in clean, open air on clean, paved surfaces.

**Severe Operation:** Prolonged operating hours or constant usage.

**Extreme Operation:**

- In sandy or dusty locations, such as cement plants, lumber mills, and coal dust or stone crushing sites.
- High-temperature locations, such as steel mills and foundries.
- Sudden temperature changes, such as constant trips from buildings into the open air, or in refrigeration plants.

If the lift truck is used in *severe* or *extreme* operating conditions, the maintenance intervals should be shortened accordingly.

### IMPORTANT

**MAINTENANCE INTERVALS.** If the lift truck is used in severe or extreme operating conditions, the maintenance intervals should be shortened accordingly.

Since the operating environments of lift trucks vary widely, the above descriptions are highly generalized and should be applied as actual conditions dictate.



**Service Chart/Lubrication Points**

A decal, similar to the illustration below, is located on the underside of the truck's engine cover. This decal is a basic guide to periodic maintenance intervals and tasks. A more detailed chart is supplied on the next page.

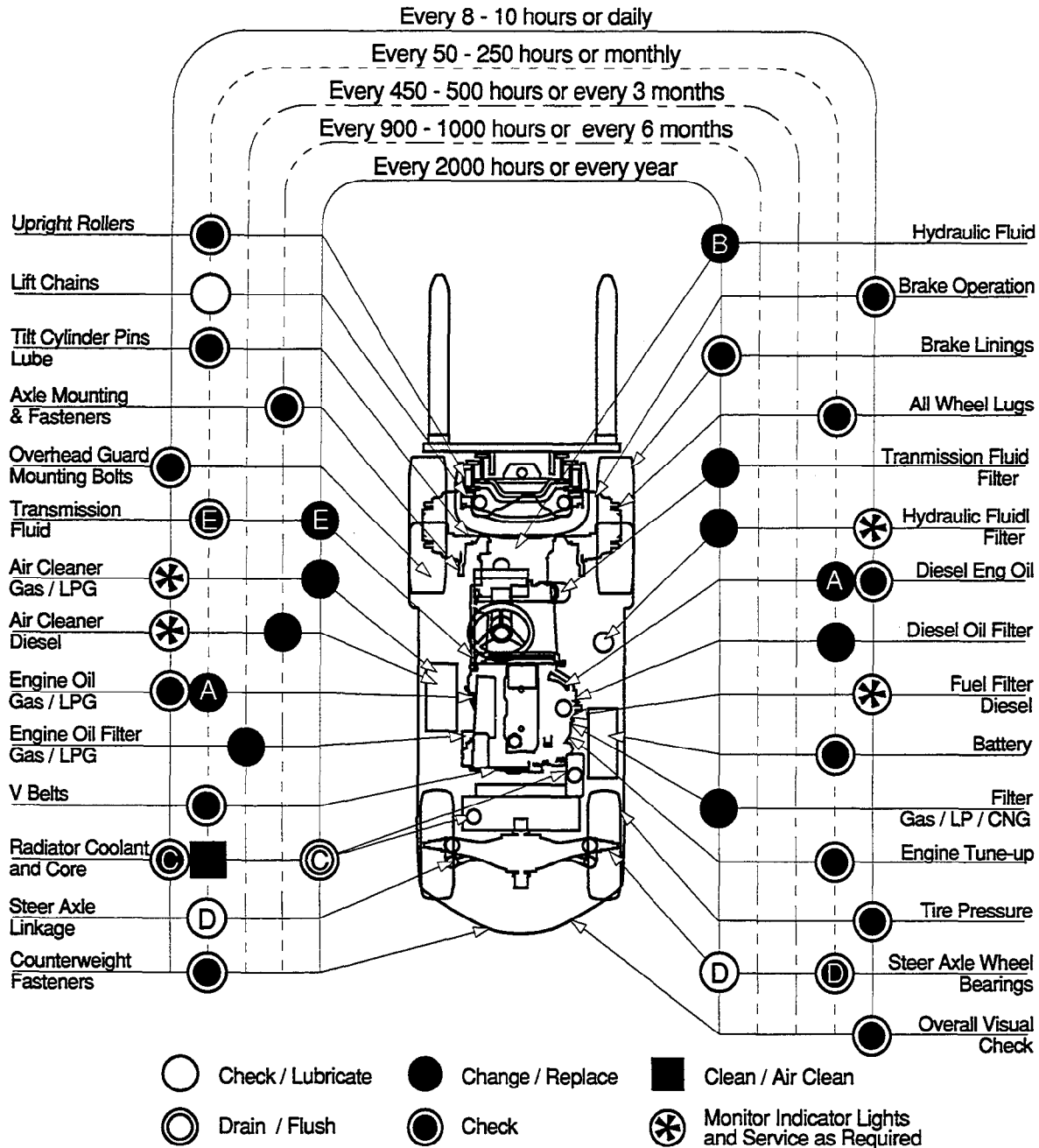

**A - Diesel Engine Oil:** 15W40  
API, CC, CD / SG, SF  
  
Gas/LPG Engine Oil: 10W30  
API, CC, CD / SG, SF

**B - Hydraulic Fluid**  
Clark # 1802155

**C - Engine Coolant**  
50 / 50 Mixture

**D - MP Grease**  
NLG # 2

**E - Transaxle Fluid**  
Clark # 2776236 used in standard transaxle. Hydrostatic transmission shares hydraulic system fluid (note B).

### Recommended Periodic Service Schedule

This chart lists maintenance tasks that should be done periodically, the suggested time intervals, and the service manual Group in which the task is covered. Apply as

appropriate for diesel, gas, and LPG trucks. Refer to Operator's Manual for Daily Checks.

TASKS	1st 50 Hours	Every 50-250 Hours	Every 450-500 Hours (or 3 months)	Every 900-1000 Hours (or 6 months)	Every 2000 Hours (or 1 year)
<b>Group PS - Periodic Maintenance</b>					
Perform Planned Maintenance inspections, lubrications, and adjustments		•			
<b>Group 00 - Engine</b>					
Exhaust smoke from gas engine- inspect (blue-oil; black-fuel)		•			
Idle/governed rpm - check/adjust		•			
Mounts / brackets - inspect/tighten		•			
Oil change - drain/fill *	•	•			
Oil filler cap & seal - clean/check		•			
Oil filter - replace	•	• (Diesel)	• (Gas/LPG)		
Oil level / condition - check	•	•			
Stall rpm - check on standard transaxle truck		•			
Tune up - determine if needed by stall check and/or functional test		•			
Valve tappet adjustment - diesel engine		•			
<b>Group 01 - Cooling System</b>					
Coolant level / condition - check/sample		•			
Coolant protection level - hydrometer test				•	
Coolant change - drain & flush					•
Coolant hoses - inspect/replace		•			•
Fan blades - inspect loose/damaged		•			
Fan belt(s) - check tension, wear	•	•			
Radiator cap - inspect/test		•			
Thermostat - test/replace					•
Water pump - check leaks/wear		•			
<b>Group 02 - Fuel System</b>					
Carburetor idle/air - check/adjust		•			
CO level - check/adjust					•
Diesel injectors/lines - clean/inspect				•	
Filler cap/screen - clean/inspect		•			
Fuel filter, diesel - replace				•	
Fuel filter, gas - replace					•
LPG lock-off valve filter - inspect/replace					•
LPG tank mounting/guard - inspect		•			
LPG tank shut-off valve - inspect/test		•			
LPG vaporizer/regulator/hoses - inspect		•			
Throttle linkage - check/adjust		•			

\* Oil change interval may be determined by laboratory analysis

# Group PS, Periodic Service



TASKS	1st 50 Hours	Every 50-250 Hours	Every 450-500 Hours (or 3 months)	Every 900-1000 Hours (or 6 months)	Every 2000 Hours (or 1 year)
<b>Group 02 - Air Intake &amp; Exhaust</b>					
Air filter element - replace				• (Diesel)	• (Gas/LPG)
Air hoses/clamps - inspect		•			
Exhaust pipe/muffler - inspect		•			
<b>Group 06 - Transaxle</b>					
Air vent - inspect, clean or replace on standard transaxle		•			
Axle end lube - clean/repack	During brake repairs				
Axle mounting bolts - inspect/tighten				•	
Charging pump - stall test standard transaxle		•			
Clutch pack operation - stall test standard transaxle		•			
Pressure checks					•
Fluid change - drain/fill					•
Fluid filter - replace	•				•
Fluid level/condition - check/sample	•	•			
Inching operation - check/test		•			
Oil cooler / lines - inspect		•			
Transmission strainer - clean on standard transaxle					•
<b>Group 12 - Ignition and Starting System</b>					
Diesel cold starting plug - test					•
Distributor cap/rotor - inspect		•			
Electronic ignition - test					•
Ignition timing - check/adjust			•		
Ignition wiring - inspect		•			
Neutral start - check		•			
Parking brake interlock - check		•			
Spark plugs - regap/replace			•		
Starter motor - inspect/test					•
Starter solenoid - inspect/test					•
<b>Group 13 - Gauges, Indicators</b>					
Hourmeter - check		•			
Lamp check - at start-up		•			
Wiring harness - inspect				•	
<b>Group 14 - Electrical: Alternator, Regulator, Battery</b>					
Alternator - inspect/test					•
Alternator drive belts - inspect/adjust	•	•			
Alternator output - test					•
Battery electrolyte level - check/add		•			
Battery condition - cranking voltage test		•			
Battery terminals/cables - clean/tighten		•			
<b>Group 22 - Wheels And Tires</b>					
Wheel mounting bolts - tighten	•	•			
Tire pressure/condition - check	•	•			



TASKS	1st 50 Hours	Every 50-250 Hours	Every 450-500 Hours (or 3 months)	Every 900-1000 Hours (or 6 months)	Every 2000 Hours (or 1 year)
<b>Group 23 - Brakes</b>					
Operation - check		•			
Service brake - check wear					•
Brake lines - check	•	•			
Parking brake - check/adjust	•	•			
<b>Group 26 - Steer Axle and Lines</b>					
Operation - check					
Power steering relief pressure - check		•			•
Steer axle mounting - inspect		•			
Steer wheel bearings - check		•			
Steer wheel bearings - lubricate/adjust					•
Steering cylinder seals - check leakage		•			
Steering linkage - lubricate		•			
<b>Group 29 - Hydraulic Pump, Sump, and Filter</b>					
Hydraulic fluid level/condition - check/sample		•			
Hydraulic fluid change - drain/fill					•
Hydraulic suction screen - clean					•
Hydraulic fluid filter - replace	•				•
Hydraulic tank breather - clean/replace	•				•
<b>Group 30 - Hydraulic Valve &amp; Linkage</b>					
Hydraulic system relief pressure - test/adjust					•
<b>Group 32 - Tilt Cylinders</b>					
Tilt cylinder adjustment - check/adjust		•			
Tilt cylinder drift - test		•			
Tilt cylinder mounting - check/tighten		•			
Tilt cylinder rod ends - check/tighten/lubricate		•			
Tilt cylinder rod/seals - check for leaks		•			
<b>Group 34 - Upright, Lift Cylinders, Carriage, Forks</b>					
Operation - check		•			
Carriage and lift chain - lubricate		•			
Carriage chain condition - inspect/adjust		•			
Forks, latches, stop pin - inspect/check wear		•			
Lift chain condition - inspect/adjust		•			
Load backrest		•			
Upright cylinder/mounting - inspect/tighten		•			
Upright lift cylinder downdrift - test		•			
Upright rollers - check		•			
Upright trunnion bolts - tighten		•			