

Maintenance and Service Manual

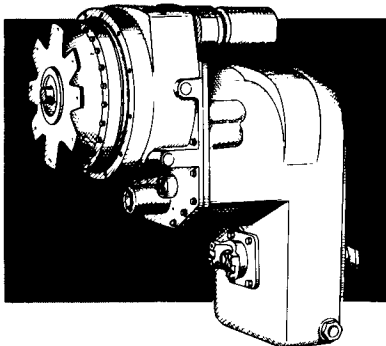
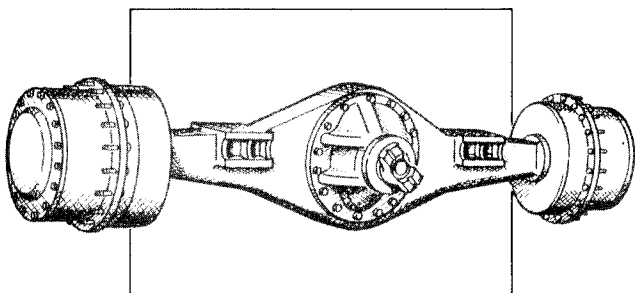
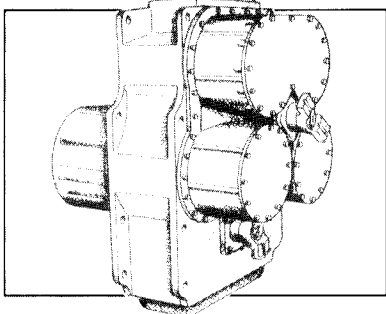
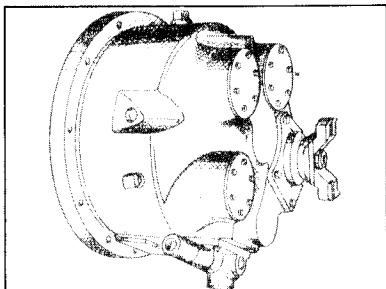

28000 Powershift Transmission

R-HR & MHR MODEL
4 SPEED LONG DROP

CLARK-HURTH →



FOREWORD

This manual has been prepared to provide the customer and the maintenance personnel with information and instructions on the maintenance and repair of the **CLARK-HURTH COMPONENTS** product.

Extreme care has been exercised in the design, selection of materials and manufacturing of these units. The slight outlay in personal attention and cost required to provide regular and proper lubrication, inspection at stated intervals, and such adjustments as may be indicated will be reimbursed many times in low cost operation and trouble free service.

In order to become familiar with the various parts of the product, its principle of operation, trouble shooting and adjustments, it is urged that the mechanic study the instructions in this manual carefully and use it as a reference when performing maintenance and repair operations.

Whenever repair or replacement of component parts is required, only **Clark-Hurth Components**-approved parts as listed in the applicable parts manual should be used. Use of "will-fit" or non-approved parts may endanger proper operation and performance of the equipment. **Clark-Hurth Components** does not warrant repair or replacement parts, nor failures resulting from the use of parts which are not supplied by or approved by **Clark-Hurth Components**. **IMPORTANT: Always furnish the Distributor with the serial and model number when ordering parts.**

TABLE OF CONTENTS

HOW THE UNITS OPERATE

SECTIONAL VIEWS AND PARTS IDENTIFICATION

Basic Design Silhouette	Fig. A
Converter Assembly	Fig. B
Converter and Transmission Case Group	Fig. C
Four Speed Case and Clutch Group	Fig. D
Clutch Group	Fig. E
Regulating Valve, Charging Pump and Filter Group	Fig. F
Control Valve Assembly	Fig. G
Axle Disconnect and Mechanical Parking Brake	Fig. H
Typical 28,000 Cross Section	Fig. I
External Plumbing Diagram	Fig. J
Typical Four Speed Power Flow	Fig. K
Clutch and Gear Arrangement	Fig. L
Shielded Bearing Installation	Fig. M
DISASSEMBLY OF TRANSMISSION	1
CLEANING AND INSPECTION	14-15
REASSEMBLY OF TRANSMISSION	15
SERVICING MACHINE AFTER TRANSMISSION OVERHAUL	30
SPECIFICATION AND SERVICE DATA	31
LUBRICATION	31
TROUBLE SHOOTING GUIDE	32
RING GEAR INSTALLATION	35-36-37-38
R MODEL SECTION	39
LF MHR MODEL SECTION	47
DRIVE PLATE INSTALLATION	69-70
SPEED SENSOR BUSHING INSTALLATION	71

NOTE: Metric Dimensions Shown in Brackets [].

TRANSMISSION ASSEMBLY

The transmission and hydraulic torque portion of the power train enacts an important role in transmitting engine power to the driving wheels. In order to properly maintain and service these units it is important to first understand their function and how they operate.

The transmission and torque converter function together and operate through a common hydraulic system. It is necessary to consider both units in the study of their function and operation.

To supplement the text below, and for reference use therewith, the following illustrations are provided:

- Basic Design Silhouette
- Converter Assembly
- Converter and Transmission Case Group
- Four Speed Case and Clutch Group
- Clutch Group
- Regulating Valve, Charging Pump and Filter Group
- Control Valve
- Axle Disconnect and Mechanical Parking Brake
- Typical 28000 Cross Section
- External Plumbing Diagram
- Typical Four Speed Power Flow
- Clutch and Gear Arrangement
- Shielded Bearing Installation
- Ring Gear Installation

The R, HR, and MHR Model Transmissions are of three basic designs.

The R Model consists of a separate torque converter, mounted to the engine with the powershift transmission remotely mounted and connected to the torque converter with a drive shaft.

The HR Model consists of a torque converter and powershifted transmission in one package mounted directly to the engine.

The MHR version is a mid-mount torque converter and transmission assembly connected to the engine by means of a drive shaft. (See Fig. A for basic design silhouette.)

The shift control valve assembly may be mounted directly on the side of the converter housing or front transmission cover, or remote mounted and connected to the transmission by means of flexible hoses. The function of the control valve assembly is to direct oil under pressure to the desired directional and speed clutch. A provision is made on certain models to neutralize the transmission when the brakes are applied. This is accomplished through use of a brake actuated shutoff valve. The speed and direction clutch assemblies are mounted inside the transmission case and are connected to the output shaft of the converter either by direct gearing or drive shaft. The purpose of the speed or directional clutches is to direct the power flow through the gear train to provide the desired speed range and direction.

An axle disconnect is optional and is located on the output shaft. The drive to the front or rear axle can be disconnected or connected by manual shifting.

HOW THE UNITS OPERATE

With the engine running, the converter charging pump draws oil from the transmission sump through the removable oil suction screen and directs it through the pressure regulating valve and oil filter.

The pressure regulating valve maintains pressure to the transmission control cover for actuating the direction and speed clutches. This requires a small portion of the total volume of oil used in the system. The remaining volume of oil is directed through the torque converter circuit to the oil cooler and returns to the transmission for positive lubrication. This regulator valve consists of a hardened valve spool operating in a closely fitted bore. The valve spool is spring loaded to hold the valve in a closed position. When a specific pressure is achieved, the valve spool works against the spring until a port is exposed along the side of the bore. This sequence of events provides the proper system pressure.

After entering the converter housing the oil is directed through the stator support to the converter blade cavity and exits in the passage between the turbine shaft and converter support. The oil then flows out of the converter to the oil cooler. After leaving the cooler, the oil is directed to a fitting on the transmission. Then through a series of tubes and passages lubricates the transmission bearings and clutches. The oil then gravity drains to the transmission sump.

The hydraulic torque converter consists basically of three elements and their related parts to multiply engine torque. The engine power is transmitted from the engine flywheel to the impeller element through the impeller cover. This element is the pump portion of the hydraulic torque converter and is the primary component which starts the oil flowing to the other components which results in torque multiplication. This element can be compared to a centrifugal pump in that it picks up fluid at its center and discharges at its outer diameter.

The torque converter turbine is mounted opposite the impeller and is connected to the output shaft of the torque converter. This element receives fluid at its outer diameter and discharges at its center. Fluid directed by the impeller out into the particular design of blading in the turbine and reaction member is the means by which the hydraulic torque converter multiplies torque.

The reaction member of the torque converter is located between and at the center or inner diameters of the impeller and turbine elements. Its function is to take the fluid which is exhausting from the inner portion of the turbine and change its direction to allow correct entry for recirculation into the impeller element.

The torque converter will multiply engine torque to its designed maximum multiplication ratio when the output shaft is at zero RPM. Therefore, we can say that as the output shaft is decreasing in speed the torque multiplication is increasing.

The shift control valve assembly consists of a valve body with selector valve spools. A detent ball and spring in the selector spool provides one position for each speed range. A detent ball and spring in the direction spool provides three positions, one each for forward, neutral and reverse.

With the engine running and the directional control lever in neutral position, oil pressure from the regulating valve is blocked at the control valve, and the transmission is in neutral. Movement of the forward and reverse spool will direct oil, under pressure to either the forward or reverse direction clutch as desired.

When either directional clutch is selected the opposite clutch is relieved of pressure and vents back through the direction selector spool. The same procedure is used in the speed selector.

The direction or speed clutch assembly consists of a drum with internal splines and a bore to receive a hydraulically actuated piston. The piston is "oil tight" by the use of sealing rings. A steel disc with external splines is inserted into the drum and rests against the piston. Next, a friction disc with splines at the inner diameter is inserted. Discs are alternated until the required total is achieved. A heavy back-up plate is then inserted and secured with a snap ring. A Hub with O.D. splines is inserted into the splines of discs with teeth on the inner diameter. The discs and hub are free to increase in speed or rotate in the opposite direction as long as no pressure is present in that specific clutch.

To engage the clutch, as previously stated, the control valve is placed in the desired position. This allows oil under pressure to flow from the control valve, through a tube, to a chosen clutch shaft. This shaft has a drilled passageway for oil under pressure to enter the shaft. Oil pressure sealing rings are located on the clutch shaft. These rings direct oil under pressure to a desired clutch. Pressure of the oil forces the piston and discs against the heavy back-up plate. The discs, with teeth on the outer diameter, clamping against discs with teeth on the inner diameter, enables the hub and clutch shaft to be locked together and allows them to drive as a unit.

There are bleed balls in the clutch piston which allow quick escape for oil when the pressure to the piston is released.

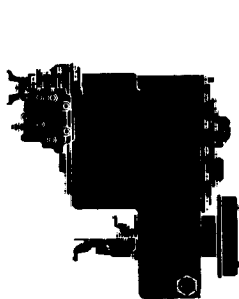

R-28000



HR-28000



MHR-28000

FIG. A

Clark 28000 Powershift Transmission 4 Speed Maintenance And Service Manual

Full download: <http://manualplace.com/download/clark-28000-powershift-transmission-4-speed-maintenance-and-service-manual>

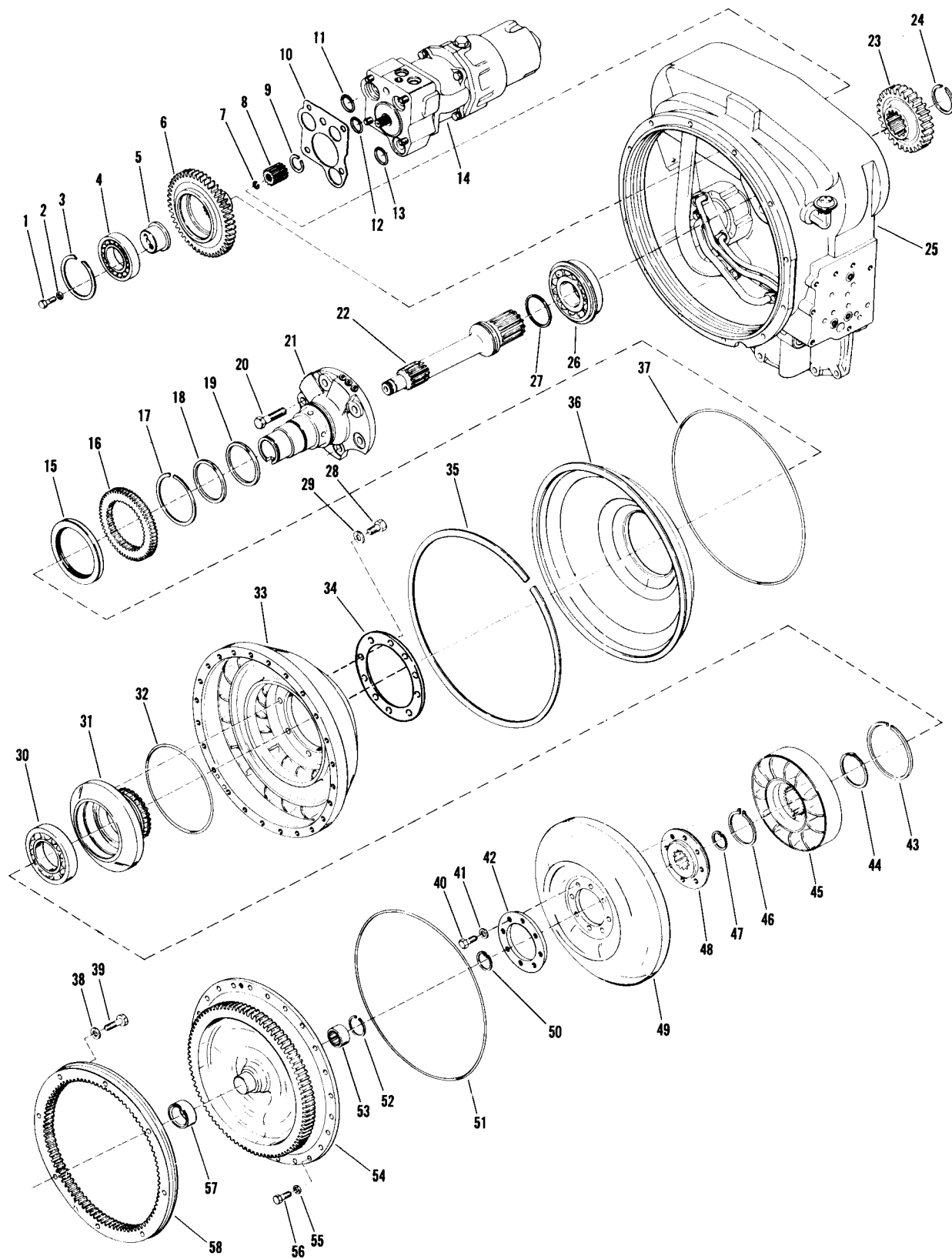

Figure B