

GROUP TAB LOCATOR

Introduction
0 Lubrication & Maintenance
2 Suspension
3 Differential & Driveline
5 Brakes
6 Clutch
7 Cooling
8A Audio
8B Chime/Buzzer
8E Electronic Control Modules
8F Engine Systems
8G Heated Systems
8H Horn
8I Ignition Control
8J Instrument Cluster
8L Lamps
8M Message Systems
8N Power Systems
8O Restraints
8P Speed Control
8Q Vehicle Theft Security
8R Wipers/Washers
8W Wiring
9 Engine
11 Exhaust System and Turbocharger
13 Frame & Bumpers
14 Fuel System
19 Steering
21 Transaxle
22 Tires/Wheels
23 Body
24 Heating & Air Conditioning
25 Emissions Control
Component and System Index

Service Manual Comment Forms (Rear of Manual)

INTRODUCTION

TABLE OF CONTENTS

	page		page
BODY CODE PLATE		VEHICLE IDENTIFICATION NUMBER	
DESCRIPTION	1	DESCRIPTION - VEHICLE IDENTIFICATION NUMBER	9
FASTENER IDENTIFICATION		VEHICLE SAFETY CERTIFICATION LABEL	
DESCRIPTION	2	DESCRIPTION	10
FASTENER USAGE		E-MARK LABEL	
DESCRIPTION		DESCRIPTION	10
DESCRIPTION - FASTENER USAGE	5	VECI LABEL	
DESCRIPTION - THREADED HOLE REPAIR ..	5	DESCRIPTION	10
INTERNATIONAL SYMBOLS		MANUFACTURER PLATE	
DESCRIPTION	5	DESCRIPTION	10
METRIC SYSTEM			
DESCRIPTION	6		
TORQUE REFERENCES			
DESCRIPTION	8		

BODY CODE PLATE

DESCRIPTION

The Body Code Plate (Fig. 1) is located in the engine compartment on the plenum behind the right side strut tower (Fig. 2). There are seven lines of information on the body code plate. Lines 4, 5, 6, and 7 are not used to define service information. Information reads from left to right, starting with line 3 in the center of the plate to line 1 at the bottom of the plate.

BODY CODE PLATE LINE 2

DIGITS 1, 2, AND 3

Paint procedure

DIGIT 4

Open Space

DIGITS 5 THROUGH 7

Primary paint

(Refer to 23 - BODY/PAINT - SPECIFICATIONS)

for Body Color Codes.

DIGIT 8 AND 9

Open Space

DIGITS 10 THROUGH 12

Secondary Paint

DIGIT 13 AND 14

Open Space

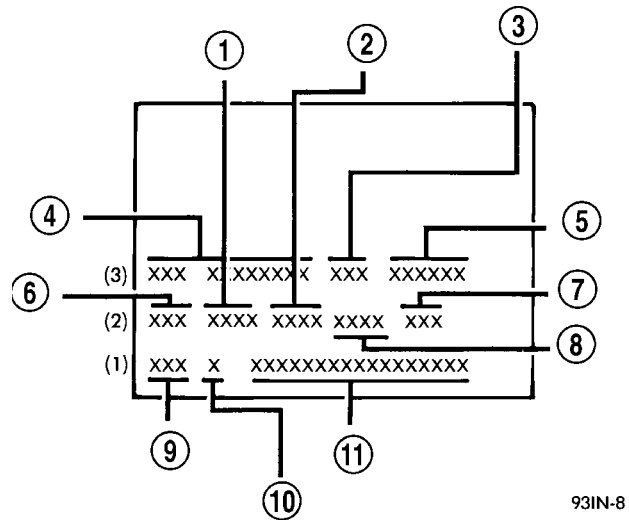

93IN-8

Fig. 1 BODY CODE PLATE

- 1 - PRIMARY PAINT
- 2 - SECONDARY PAINT
- 3 - VINYL ROOF
- 4 - VEHICLE ORDER NUMBER
- 5 - CAR LINE SHELL
- 6 - PAINT PROCEDURE
- 7 - ENGINE
- 8 - TRIM
- 9 - TRANSMISSION
- 10 - MARKET
- 11 - VIN

DIGITS 15 THROUGH 18

Interior Trim Code

DIGIT 19

Open Space

BODY CODE PLATE (Continued)

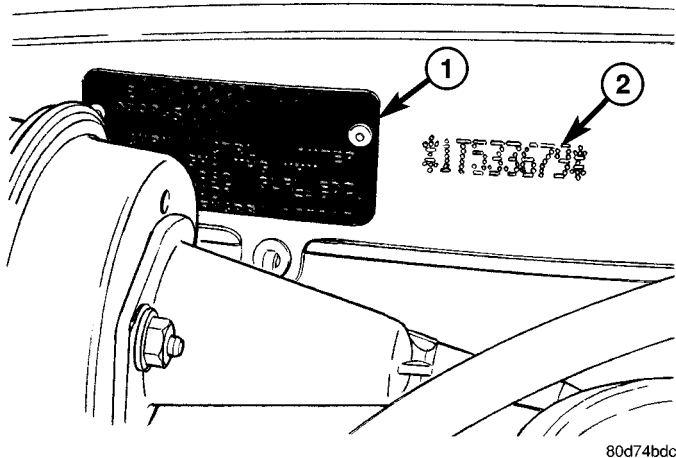

Fig. 2 BODY CODE PLATE 2

- 1 - BODY CODE PLATE
2 - BODY CODE EMBOSS

DIGITS 20, 21, AND 22

Engine Code

- EJD = 1.6L Four Cylinder 16 Valves SOHC Gasoline
- ECC = 2.0L Four Cylinder 16 Valves DOHC Gasoline
- EDJ = 2.2L Four Cylinder Turbo Diesel Engine
- EDZ = 2.4L Four Cylinder 16 Valves DOHC Gasoline
- EDV = 2.4L Four Cylinder 16 Valves DOHC H.O. Turbo Gasoline

DIGIT 23

Open Space

BODY CODE PLATE LINE 1

DIGITS 1, 2, AND 3

Transaxle Codes

- DGL = 41TE 4-Speed Electronic Automatic Transaxle
- DD5 = NV T350 5-Speed Manual Transaxle
- DDD = GETRAG 288 5-Speed Manual Transaxle

DIGIT 4

Open Space

DIGIT 5

Market Code

- C = Canada
- B = International
- M = Mexico
- U = United States

DIGIT 6

Open Space

DIGITS 7 THROUGH 23

Vehicle Identification Number

- (Refer to VEHICLE DATA/VEHICLE INFORMATION/VEHICLE IDENTIFICATION NUMBER - DESCRIPTION) for proper breakdown of VIN code.

IF TWO BODY CODE PLATES ARE REQUIRED

The last code shown on either plate will be followed by END. When two plates are required, the last code space on the first plate will indicate (CTD)

When a second plate is required, the first four spaces of each line will not be used due to overlap of the plates.

FASTENER IDENTIFICATION

DESCRIPTION

The SAE bolt strength grades range from grade 2 to grade 8. The higher the grade number, the greater the bolt strength. Identification is determined by the line marks on the top of each bolt head. The actual bolt strength grade corresponds to the number of line marks plus 2. The most commonly used metric bolt strength classes are 9.8 and 10.9. The metric strength class identification number is imprinted on the head of the bolt. The higher the class number, the greater the bolt strength. Some metric nuts are imprinted with a single-digit strength class on the nut face. Refer to the Fastener Identification and Fastener Strength Charts (Fig. 3) and (Fig. 4).

FASTENER IDENTIFICATION (Continued)

Bolt Markings and Torque - Metric

Commercial Steel Class

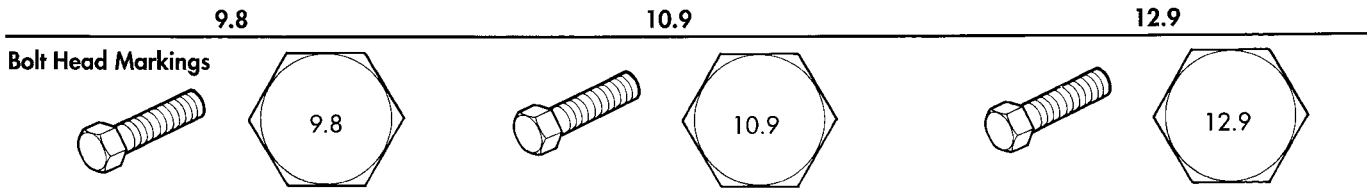

Body Size	Torque				Torque				Torque			
	Cast Iron		Aluminum		Cast Iron		Aluminum		Cast Iron		Aluminum	
	Diam. mm	N•m	ft-lb	N•m	ft-lb	N•m	ft-lb	N•m	ft-lb	N•m	ft-lb	N•m
6	9	5	7	4	14	9	11	7	14	9	11	7
7	14	9	11	7	18	14	14	11	23	18	18	14
8	25	18	18	14	32	23	25	18	36	27	28	21
10	40	30	30	25	60	45	45	35	70	50	55	40
12	70	55	55	40	105	75	80	60	125	95	100	75
14	115	85	90	65	160	120	125	95	195	145	150	110
16	180	130	140	100	240	175	190	135	290	210	220	165
18	230	170	180	135	320	240	250	185	400	290	310	230

Bolt Markings and Torque Values - U.S. Customary

SAE Grade Number

5

8

Bolt Head Markings

These are all SAE Grade 5 (3) line

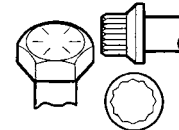

Bolt Torque - Grade 5 Bolt

Bolt Torque - Grade 8 Bolt

Body Size	Cast Iron		Aluminum		Cast Iron		Aluminum	
	N•m	ft-lb	N•m	ft-lb	N•m	ft-lb	N•m	ft-lb
1/4 - 20	9	7	8	6	15	11	12	9
- 28	12	9	9	7	18	13	14	10
5/16 - 18	20	15	16	12	30	22	24	18
- 24	23	17	19	14	33	24	25	19
3/8 - 16	40	30	25	20	55	40	40	30
- 24	40	30	35	25	60	45	45	35
7/16 - 14	60	45	45	35	90	65	65	50
- 20	65	50	55	40	95	70	75	55
1/2 - 13	95	70	75	55	130	95	100	75
- 20	100	75	80	60	150	110	120	90
9/16 - 12	135	100	110	80	190	140	150	110
- 18	150	110	115	85	210	155	170	125
5/8 - 11	180	135	150	110	255	190	205	150
- 18	210	155	160	120	290	215	230	170
3/4 - 10	325	240	255	190	460	340	365	270
- 16	365	270	285	210	515	380	410	300
7/8 - 9	490	360	380	280	745	550	600	440
- 14	530	390	420	310	825	610	660	490
1 - 8	720	530	570	420	1100	820	890	660
- 14	800	590	650	480	1200	890	960	710

Fig. 3 FASTENER IDENTIFICATION

FASTENER IDENTIFICATION (Continued)

HOW TO DETERMINE BOLT STRENGTH









	Mark	Class		Mark	Class
Hexagon head bolt	 <p>Bolt head No.</p> <p>4 — 4T 5 — 5T 6 — 6T 7 — 7T 8 — 8T 9 — 9T 10 — 10T 11 — 11T</p>		Stud bolt	 <p>No mark</p>	4T
	 <p>No mark</p>	4T			
Hexagon flange bolt w/washer hexagon bolt	 <p>No mark</p>	4T	Welded bolt	 <p>Grooved</p>	6T
Hexagon head bolt	 <p>Two protruding lines</p>	5T			
Hexagon flange bolt w/washer hexagon bolt	 <p>Two protruding lines</p>	6T		4T	
Hexagon head bolt	 <p>Three protruding lines</p>	7T			
Hexagon head bolt	 <p>Four protruding lines</p>	8T			

Fig. 4 FASTENER STRENGTH

FASTENER USAGE

DESCRIPTION

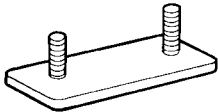
DESCRIPTION - FASTENER USAGE

WARNING: USE OF AN INCORRECT FASTENER MAY RESULT IN COMPONENT DAMAGE OR PERSONAL INJURY.

Fasteners and torque specifications references in this Service Manual are identified in metric and SAE format.

During any maintenance or repair procedures, it is important to salvage all fasteners (nuts, bolts, etc.) for reassembly. If the fastener is not salvageable, a fastener of equivalent specification must be used.

























DESCRIPTION - THREADED HOLE REPAIR

Most stripped threaded holes can be repaired using a Helicoil®. Follow the vehicle or Helicoil® recommendations for application and repair procedures.

INTERNATIONAL SYMBOLS

DESCRIPTION

The graphic symbols illustrated in the following International Control and Display Symbols Chart (Fig. 5) are used to identify various instrument controls. The symbols correspond to the controls and displays that are located on the instrument panel.

 1	 2	 3	 4	 5	 6
 7	 8	 9	 10	 11	 12
 13	 14	 15	 16	 17	 18
 19	 20	 21	 22	 23	 24

80be4788

Fig. 5 INTERNATIONAL CONTROL AND DISPLAY SYMBOLS

- | | | | |
|----|--------------------------------------|----|----------------------------|
| 1 | High Beam | 13 | Rear Window Washer |
| 2 | Fog Lamps | 14 | Fuel |
| 3 | Headlamp, Parking Lamps, Panel Lamps | 15 | Engine Coolant Temperature |
| 4 | Turn Warning | 16 | Battery Charging Condition |
| 5 | Hazard Warning | 17 | Engine Oil |
| 6 | Windshield Washer | 18 | Seat Belt |
| 7 | Windshield Wiper | 19 | Brake Failure |
| 8 | Windshield Wiper and Washer | 20 | Parking Brake |
| 9 | Windscreen Demisting and Defrosting | 21 | Front Hood |
| 10 | Ventilating Fan | 22 | Rear hood (Decklid) |
| 11 | Rear Window Defogger | 23 | Horn |
| 12 | Rear Window Wiper | 24 | Lighter |

METRIC SYSTEM

The following chart will assist in converting metric units to equivalent English and SAE units, or vice versa.

DESCRIPTION

The metric system is based on quantities of one, ten, one hundred, one thousand and one million.

CONVERSION FORMULAS AND EQUIVALENT VALUES

MULTIPLY	BY	TO GET	MULTIPLY	BY	TO GET
in-lbs	x 0.11298	= Newton Meters (N·m)	N·m	x 8.851	= in-lbs
ft-lbs	x 1.3558	= Newton Meters (N·m)	N·m	x 0.7376	= ft-lbs
Inches Hg (60° F)	x 3.377	= Kilopascals (kPa)	kPa	x 0.2961	= Inches Hg
psi	x 6.895	= Kilopascals (kPa)	kPa	x 0.145	= psi
Inches	x 25.4	= Millimeters (mm)	mm	x 0.03937	= Inches
Feet	x 0.3048	= Meters (M)	M	x 3.281	= Feet
Yards	x 0.9144	= Meters	M	x 1.0936	= Yards
mph	x 1.6093	= Kilometers/Hr. (Km/h)	Km/h	x 0.6214	= mph
Feet/Sec	x 0.3048	= Meters/Sec (M/S)	M/S	x 3.281	= Feet/Sec
mph	x 0.4470	= Meters/Sec (M/S)	M/S	x 2.237	= mph
Kilometers/Hr. (Km/h)	x 0.27778	= Meters/Sec (M/S)	M/S	x 3.600	Kilometers/Hr. (Km/h)

COMMON METRIC EQUIVALENTS

1 inch = 25 Millimeters	1 Cubic Inch = 16 Cubic Centimeters
1 Foot = 0.3 Meter	1 Cubic Foot = 0.03 Cubic Meter
1 Yard = 0.9 Meter	1 Cubic Yard = 0.8 Cubic Meter
1 Mile = 1.6 Kilometers	

Refer to the Metric Conversion Chart to convert torque values listed in metric Newton- meters (N·m).

Also, use the chart to convert between millimeters (mm) and inches (in.) (Fig. 6).

METRIC SYSTEM (Continued)

in-lbs to N•m

N•m to in-lbs

in-lb	N•m	in-lb	N•m	in-lb	N•m	in-lb	N•m	in-lb	N•m	N•m	in-lb	N•m	in-lb	N•m	in-lb	N•m	in-lb	N•m	in-lb	N•m
2	.2260	42	4.7453	82	9.2646	122	13.7839	162	18.3032	.2	1.7702	4.2	37.1747	8.2	72.5792	12.2	107.9837	16.2	143.3882	
4	.4519	44	4.9713	84	9.4906	124	14.0099	164	18.5292	.4	3.5404	4.4	38.9449	8.4	74.3494	12.4	109.7539	16.4	145.1584	
6	.6779	46	5.1972	86	9.7165	126	14.2359	166	18.7552	.6	5.3107	4.6	40.7152	8.6	76.1197	12.6	111.5242	16.6	146.9287	
8	.9039	48	5.4232	88	9.9425	128	14.4618	168	18.9811	.8	7.0809	4.8	42.4854	8.8	77.8899	12.8	113.2944	16.8	148.6989	
10	1.1298	50	5.6492	90	10.1685	130	14.6878	170	19.2071	1	8.8511	5	44.2556	9	79.6601	13	115.0646	17	150.4691	
12	1.3558	52	5.8751	92	10.3944	132	14.9138	172	19.4331	1.2	10.6213	5.2	46.0258	9.2	81.4303	13.2	116.8348	17.2	152.2393	
14	1.5818	54	6.1011	94	10.6204	134	15.1397	174	19.6590	1.4	12.3916	5.4	47.7961	9.4	83.2006	13.4	118.6051	17.4	154.0096	
16	1.8077	56	6.3270	96	10.8464	136	15.3657	176	19.8850	1.6	14.1618	5.6	49.5663	9.6	84.9708	13.6	120.3753	17.6	155.7798	
18	2.0337	58	6.5530	98	11.0723	138	15.5917	178	20.1110	1.8	15.9320	5.8	51.3365	9.8	86.7410	13.8	122.1455	17.8	157.5500	
20	2.2597	60	6.7790	100	11.2983	140	15.8176	180	20.3369	2	17.7022	6	53.1067	10	88.5112	14	123.9157	18	159.3202	
22	2.4856	62	7.0049	102	11.5243	142	16.0436	182	20.5629	2.2	19.4725	6.2	54.8770	10.2	90.2815	14.2	125.6860	18.5	163.7458	
24	2.7116	64	7.2309	104	11.7502	144	16.2696	184	20.7889	2.4	21.2427	6.4	56.6472	10.4	92.0517	14.4	127.4562	19	168.1714	
26	2.9376	66	7.4569	106	11.9762	146	16.4955	186	21.0148	2.6	23.0129	6.6	58.4174	10.6	93.8219	14.6	129.2264	19.5	172.5970	
28	3.1635	68	7.6828	108	12.2022	148	16.7215	188	21.2408	2.8	24.7831	6.8	60.1876	10.8	95.5921	14.8	131.0066	20	177.0225	
30	3.3895	70	7.9088	110	12.4281	150	16.9475	190	21.4668	3	26.5534	7	61.9579	11	97.3624	15	132.7669	20.5	181.4480	
32	3.6155	72	8.1348	112	12.6541	152	17.1734	192	21.6927	3.2	28.3236	7.2	63.7281	11.2	99.1326	15.2	134.5371	21	185.8736	
34	3.8414	74	8.3607	114	12.8801	154	17.3994	194	21.9187	3.4	30.0938	7.4	65.4983	11.4	100.9028	15.4	136.3073	22	194.7247	
36	4.0674	76	8.5867	116	13.1060	156	17.6253	196	22.1447	3.6	31.8640	7.6	67.2685	11.6	102.6730	15.6	138.0775	23	203.5759	
38	4.2934	78	8.8127	118	13.3320	158	17.8513	198	22.3706	3.8	33.6342	7.8	69.0388	11.8	104.4433	15.8	139.8478	24	212.4270	
40	4.5193	80	9.0386	120	13.5580	160	18.0773	200	22.5966	4	35.4045	8	70.8090	12	106.2135	16	141.6180	25	221.2781	

ft-lbs to N•m

N•m to ft-lbs

ft-lb	N•m	ft-lb	N•m	ft-lb	N•m	ft-lb	N•m	ft-lb	N•m	N•m	ft-lb	N•m	ft-lb	N•m	ft-lb	N•m	ft-lb	N•m	ft-lb	N•m
1	1.3558	21	28.4722	41	55.5885	61	82.7049	81	109.8212	1	.7376	21	15.9888	41	30.2400	61	44.9913	81	59.7425	
2	2.7116	22	29.8280	42	56.9444	62	84.0607	82	111.1770	2	1.4751	22	16.2264	42	30.9776	62	45.7289	82	60.4801	
3	4.0675	23	31.1838	43	58.3002	63	85.4165	83	112.5328	3	2.2127	23	16.9639	43	31.7152	63	46.4664	83	61.2177	
4	5.4233	24	32.5396	44	59.6560	64	86.7723	84	113.8888	4	2.9502	24	17.7015	44	32.4527	64	47.2040	84	61.9552	
5	6.7791	25	33.8954	45	61.0118	65	88.1281	85	115.2446	5	3.6878	25	18.4391	45	33.1903	65	47.9415	85	62.6928	
6	8.1349	26	35.2513	46	62.3676	66	89.4840	86	116.6004	6	4.4254	26	19.1766	46	33.9279	66	48.6791	86	63.4303	
7	9.4907	27	36.6071	47	63.7234	67	90.8398	87	117.9562	7	5.1629	27	19.9142	47	34.6654	67	49.4167	87	64.1679	
8	10.8465	28	37.9629	48	65.0793	68	92.1956	88	119.3120	8	5.9005	28	20.6517	48	35.4030	68	50.1542	88	64.9545	
9	12.2024	29	39.3187	49	66.4351	69	93.5514	89	120.6678	9	6.6381	29	21.3893	49	36.1405	69	50.8918	89	65.6430	
10	13.5582	30	40.6745	50	67.7909	70	94.9073	90	122.0236	10	7.3756	30	22.1269	50	36.8781	70	51.6293	90	66.3806	
11	14.9140	31	42.0304	51	69.1467	71	96.2631	91	123.3794	11	8.1132	31	22.8644	51	37.6157	71	52.3669	91	67.1181	
12	16.2698	32	43.3862	52	70.5025	72	97.6189	92	124.7352	12	8.8507	32	23.6020	52	38.3532	72	53.1045	92	67.8557	
13	17.6256	33	44.7420	53	71.8583	73	98.9747	93	126.0910	13	9.5883	33	24.3395	53	39.0908	73	53.8420	93	68.5933	
14	18.9815	34	46.0978	54	73.2142	74	100.3316	94	127.4468	14	10.3259	34	25.0771	54	39.8284	74	54.5720	94	69.3308	
15	20.3373	35	47.4536	55	74.5700	75	101.6862	95	128.8026	15	11.0634	35	25.8147	55	40.5659	75	55.3172	95	70.0684	
16	21.6931	36	48.8094	56	75.9258	76	103.0422	96	130.1586	16	11.8010	36	26.5522	56	41.3035	76	56.0547	96	70.8060	
17	23.0489	37	50.1653	57	77.2816	77	104.3980	97	131.5144	17	12.5386	37	27.2898	57	42.0410	77	56.7923	97	71.5435	
18	24.4047	38	51.5211	58	78.6374	78	105.7538	98	132.8702	18	13.2761	38	28.0274	58	42.7786	78	57.5298	98	72.2811	
19	25.7605	39	52.8769	59	79.9933	79	107.1196	99	134.2260	19	14.0137	39	28.7649	59	43.5162	79	58.2674	99	73.0187	
20	27.1164	40	54.2327	60	81.3491	80	108.4654	100	135.5820	20	14.7512	40	29.5025	60	44.2537	80	59.0050	100	73.7562	

in. to mm

mm to in.

in.	mm	in.	mm	in.	mm	in.	mm	in.	mm	mm	in.	mm	in.	mm	in.	mm	in.	mm	in.	mm	in.
.01	.254	.21	5.334	.41	10.414	.61	15.494	.81	20.574	.01	.00039	.21	.00827	.41	.01614	.61	.02402	.81	.03189		
.02	.508	.22	5.588	.42	10.668	.62	15.748	.82	20.828	.02	.00079	.22	.00866	.42	.01654	.62	.02441	.82	.03228		
.03	.762	.23	5.842	.43	10.922	.63	16.002	.83	21.082	.03	.00118	.23	.00906	.43	.01693	.63	.02480	.83	.03268		
.04	1.016	.24	6.096	.44	11.176	.64	16.256	.84	21.336	.04	.00157	.24	.00945	.44	.01732	.64	.02520	.84	.03307		
.05	1.270	.25	6.350	.45	11.430	.65	16.510	.85	21.590	.05	.00197	.25	.00984	.45	.01772	.65	.02559	.85	.03346		
.06	1.524	.26	6.604	.46	11.684	.66	16.764	.86	21.844	.06	.00236	.26	.01024	.46	.01811	.66	.02598	.86	.03386		
.07	1.778	.27	6.858	.47	11.938	.67	17.018	.87	22.098	.07	.00276	.27	.01063	.47	.01850	.67	.02638	.87	.03425		
.08	2.032	.28	7.112	.48	12.192	.68	17.272	.88	22.352	.08	.00315	.28	.01102	.48	.01890	.68	.02677	.88	.03465		
.09	2.286	.29	7.366	.49	12.446	.69	17.526	.89	22.606	.09	.00354	.29	.01142	.49	.01929	.69	.02717	.89	.03504		
.10	2.540	.30	7.620	.50	12.700	.70	17.780	.90	22.860	.10	.00394	.30	.01181	.50	.01969	.70	.02756	.90	.03543		
.11	2.794	.31	7.874	.51	12.954	.71	18.034	.91	23.114	.11	.00433	.31	.01220	.51	.02008	.71	.02795	.91	.03583		
.12	3.048	.32	8.128	.52	13.208	.72	18.288	.92	23.368	.12	.00472	.32	.01260	.52	.02047	.72	.02835	.92	.03622		
.13	3.302	.33	8.382	.53	13.462	.73	18.542	.93	23.622	.13	.00512	.33	.01299	.53	.02087	.73	.02874	.93	.03661		
.14	3.556	.34	8.636	.54	13.716	.74	18.796	.94	23.876	.14	.00551	.34	.01339	.54	.02126	.74	.02913	.94	.03701		
.15	3.810	.35	8.890	.55	13.970	.75	19.050	.95	24.130	.15	.00591	.35	.01378	.55	.02165	.75	.02953	.95	.03740		
.16	4.064	.36	9.144	.56	14.224	.76	19.304	.96	24.384	.16	.00630	.36	.01417	.56	.02205	.76	.02992	.96	.03780		
.17	4.318	.37	9.398	.57	14.478	.77	19.558	.97	24.638	.17	.00669	.37	.01457	.57	.02244	.77	.03032	.97	.03819		
.18	4.572	.38	9.652	.58	14.732	.78	19.812	.98	24.892	.18	.00709	.38	.01496	.58	.02283	.78	.03071	.98	.03858		
.19	4.826	.39	9.906	.59	14.986	.79	20.066	.99	25.146	.19	.00748	.39	.01535	.59	.02323	.79	.03110	.99	.03898		
.20	5.080	.40	10.160	.60	15.240	.80	20.320	1.00	25.400	.20	.00787</										

TORQUE REFERENCES

tions Chart for torque references not listed in the individual torque charts (Fig. 7).

DESCRIPTION

Individual Torque Charts appear within many of the Groups. Refer to the Standard Torque Specifica-

SPECIFIED TORQUE FOR STANDARD BOLTS

Class	Diameter mm	Pitch mm	Specified torque					
			Hexagon head bolt			Hexagon flange bolt		
			N•m	kgf-cm	ft-lbf	N•m	kgf-cm	ft-lbf
4T	6	1	5	55	48 in.-lbf	6	60	52 in.-lbf
	8	1.25	12.5	130	9	14	145	10
	10	1.25	26	260	19	29	290	21
	12	1.25	47	480	35	53	540	39
	14	1.5	74	760	55	84	850	61
	16	1.5	115	1,150	83	—	—	—
5T	6	1	6.5	65	56 in.-lbf	7.5	75	65 in.-lbf
	8	1.25	15.5	160	12	17.5	175	13
	10	1.25	32	330	24	36	360	26
	12	1.25	59	600	43	65	670	48
	14	1.5	91	930	67	100	1,050	76
	16	1.5	140	1,400	101	—	—	—
6T	6	1	8	80	69 in.-lbf	9	90	78 in.-lbf
	8	1.25	19	195	14	21	210	15
	10	1.25	39	400	29	44	440	32
	12	1.25	71	730	53	80	810	59
	14	1.5	110	1,100	80	125	1,250	90
	16	1.5	170	1,750	127	—	—	—
7T	6	1	10.5	110	8	12	120	9
	8	1.25	25	260	19	28	290	21
	10	1.25	52	530	38	58	590	43
	12	1.25	95	970	70	105	1,050	76
	14	1.5	145	1,500	108	165	1,700	123
	16	1.5	230	2,300	166	—	—	—
8T	8	1.25	29	300	22	33	330	24
	10	1.25	61	620	45	68	690	50
	12	1.25	110	1,100	80	120	1,250	90
9T	8	1.25	34	340	25	37	380	27
	10	1.25	70	710	51	78	790	57
	12	1.25	125	1,300	94	140	1,450	105
10T	8	1.25	38	390	28	42	430	31
	10	1.25	78	800	58	88	890	64
	12	1.25	140	1,450	105	155	1,600	116
11T	8	1.25	42	430	31	47	480	35
	10	1.25	87	890	64	97	990	72
	12	1.25	155	1,600	116	175	1,800	130

Fig. 7 TORQUE SPECIFICATIONS

VEHICLE IDENTIFICATION NUMBER

DESCRIPTION - VEHICLE IDENTIFICATION NUMBER

The Vehicle Identification Number (VIN) is located on the upper left corner of the instrument panel, near the left A-Pillar. The VIN consists of 17 characters in a combination of letters and numbers that provide specific information about the vehicle (Fig. 8). Refer to VIN Code Decoding Chart.

To protect the consumer from theft and possible fraud the manufacturer is required to include a Check Digit at the ninth position of the Vehicle Identification Number. The check digit is used by the manufacturer and government agencies to verify the authenticity of the vehicle and official documentation. The formula to use the check digit is not released to the general public.

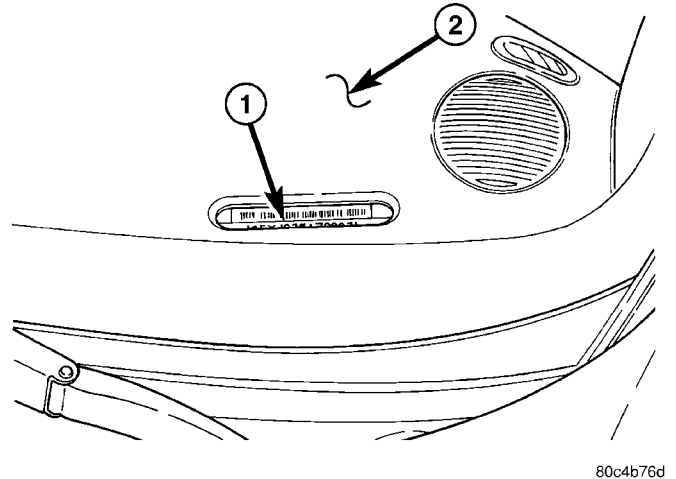

Fig. 8 VEHICLE IDENTIFICATION NUMBER LOCATION

- 1 - Vehicle Identification Number (VIN)
2 - Instrument Panel

VIN CODE DECODING

POSITION	INTERPRETATION	CODE = DESCRIPTION
1	Country of Origin	1 = Built in United States by DiamlerChrysler 3 = Built in Mexico by DiamlerChrysler De Mexico
2	Make	C = Chrysler
3	Vehicle Type	4 = Multi-purpose Passenger Vehicle Less Side Air Bags 8 = Multi-purpose Passenger Vehicle with Side Air Bags
4	Other	F = 1815 - 2267 KG (4000 - 5000 lbs.)
5	Line	Y = Cruiser (LHD)
5 - Export	Line	E = Cruiser (LHD) Z = Cruiser (RHD)
6	Series	4 = High Line 5 = Premium 6 = Sport X = Special
6 - Export	Transmission	B = 4-Speed Automatic N = 5-Speed Manual
7	Body Style	8 = Hatchback
8	Engine	9 = 2.0L 4 Cyl. Gasoline DOHC (MPI) B = 2.4 L 4 Cyl. 16 Valve Gasoline DOHC G = 2.4 L 4 Cyl. 16 Valve Gasoline DOHC H.O.
8 - Export	Engine	F = 1.6L 4 Cyl. 16V Gasoline SOHC 9 = 2.0L 4 Cyl. Gasoline DOHC (MPI) U = 2.2L 4 Cyl. Turbo Diesel Engine (MPI)
9	Check Digit	See explanation in this section.
10	Model Year	3 = 2003
11	Assembly Plant	T = Toluca Assembly U = Graz Assembly
12 Though 17	Vehicle Build Sequence	6 digit number assigned by assembly plant.

VEHICLE SAFETY CERTIFICATION LABEL

DESCRIPTION

A vehicle safety certification label is attached to the rear shutface of the driver's door (Fig. 9). This label indicates date of manufacture (month and year), Gross Vehicle Weight Rating (GVWR), Gross Axle Weight Rating (GAWR) front, Gross Axle Weight Rating (GAWR) rear and the Vehicle Identification Number (VIN). The Month, Day and Hour of manufacture is also included.

All communications or inquiries regarding the vehicle should include the Month-Day-Hour and Vehicle Identification Number.

MFD BY	DAIMLER CHRYSLER CORPORATION	DATE OF MFR	1-96 C	GVWR	2268 KG (05000 LB)
GAWR FRONT	WITH TIRES	RIMS AT	COLD		
1203 KG (2650 LB)	P195/75R14	14 X 5.5	380 KPA(35 PSI)		
GAWR REAR	WITH TIRES	RIMS AT	COLD		
1225 KG (2700 LB)	P195/75R14	14 X 5.5	380 KPA(35 PSI)		

THIS VEHICLE CONFORMS TO ALL APPLICABLE FEDERAL MOTOR VEHICLE SAFETY STANDARDS IN EFFECT ON THE DATE OF MANUFACTURE SHOWN ABOVE.

VIN: XXXXXXXXXXXXXXXX TYPE: SINGLE X DUAL



MDH: 010615 021 PAINT:POP VEHICLE MADE IN CANADA TRIM:C5C3 4848505

Fig. 9 VEHICLE SAFETY CERTIFICATION LABEL - TYPICAL

E-MARK LABEL

DESCRIPTION

An E-mark Label (Fig. 10) is located on the rear shut face of the driver's door. The label contains the following information:

- Date of Manufacture
- Month-Day-Hour (MDH)
- Vehicle Identification Number (VIN)
- Country Codes
- Regulation Number
- Regulation Amendment Number
- Approval Number

VECI LABEL

DESCRIPTION

All models have a Vehicle Emission Control Information (VECI) Label. Chrysler permanently attaches

Date of Manufacture: 05-95 MDH: 052915
VIN: XXXXXXXXXXXXXXXX

E4	21	0195002	E11	13	063098
	26	0195001		14	030169
E5	10	010035	E11	17	040212
	11	020011		39	00155
	18	010010		44	0244038
	28	010016		51	011082
	46	010019		79	00155
	85	000044			
E11	12	030263	E11	48	005003

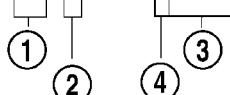

Fig. 10 E-MARK LABEL

- 1 - COUNTRY CODE
- 2 - REGULATION NUMBER
- 3 - APPROVAL NUMBER
- 4 - AMENDMENT NUMBER

the label in the engine compartment. It cannot be removed without defacing information and destroying the label.

The label contains the vehicle's emission specifications and vacuum hose routings. All hoses must be connected and routed according to the label.

MANUFACTURER PLATE

DESCRIPTION

The Manufacturer Plate (Fig. 11) is located in the engine compartment on the passenger side rear corner of the hood. The plate contains five lines of information:

1. Vehicle Identification Number (VIN)
2. Gross Vehicle Mass (GVM)
3. Gross Train Mass (GTM)
4. Gross Front Axle Rating (GFAR)
5. Gross Rear Axle Rating (GRAR)

DAIMLERCHRYSLER CORPORATION

XXXXXXXXXXXXXXXXXXXX

XXXX KG

XXXX KG

1 XXXX KG

2 XXXX KG

Fig. 11 MANUFACTURER PLATE

LUBRICATION & MAINTENANCE







TABLE OF CONTENTS

	page		page
INTERNATIONAL SYMBOLS		LUBRICATION POINTS	
DESCRIPTION	1	DESCRIPTION	5
FLUID TYPES		MAINTENANCE SCHEDULES	
DESCRIPTION		DESCRIPTION	5
DESCRIPTION - ENGINE OIL AND LUBRICANTS	1	HOISTING	
DESCRIPTION - ENGINE COOLANT	3	STANDARD PROCEDURE - HOISTING	14
DESCRIPTION - TRANSMISSION FLUID	3	JUMP STARTING	
DESCRIPTION - FUEL REQUIREMENTS	3	STANDARD PROCEDURE - JUMP STARTING	14
FLUID CAPACITIES		TOWING	
SPECIFICATIONS - FLUID CAPACITIES	5	STANDARD PROCEDURE - TOWING	15
FLUID FILL/CHECK LOCATIONS			
DESCRIPTION	5		

INTERNATIONAL SYMBOLS

DESCRIPTION

DaimlerChrysler Corporation uses international symbols to identify engine compartment lubricant and fluid inspection and fill locations (Fig. 1).

	ENGINE OIL		BRAKE FLUID
	AUTOMATIC TRANSMISSION FLUID		POWER STEERING FLUID
	ENGINE COOLANT		WINDSHIELD WASHER FLUID

8097ddb

Fig. 1 INTERNATIONAL SYMBOLS

FLUID TYPES

DESCRIPTION

DESCRIPTION - ENGINE OIL AND LUBRICANTS

WARNING: NEW OR USED ENGINE OIL CAN BE IRRITATING TO THE SKIN. AVOID PROLONGED OR REPEATED SKIN CONTACT WITH ENGINE OIL.

CONTAMINANTS IN USED ENGINE OIL, CAUSED BY INTERNAL COMBUSTION, CAN BE HAZARDOUS TO YOUR HEALTH. THOROUGHLY WASH EXPOSED SKIN WITH SOAP AND WATER. DO NOT WASH SKIN WITH GASOLINE, DIESEL FUEL, THINNER, OR SOLVENTS, HEALTH PROBLEMS CAN RESULT. DO NOT POLLUTE, DISPOSE OF USED ENGINE OIL PROPERLY. CONTACT YOUR DEALER OR GOVERNMENT AGENCY FOR LOCATION OF COLLECTION CENTER IN YOUR AREA.

When service is required, DaimlerChrysler Corporation recommends that only Mopar® brand parts, lubricants and chemicals be used. Mopar® provides the best engineered products for servicing DaimlerChrysler Corporation vehicles.

Only lubricants bearing designations defined by the following organization should be used.

- Society of Automotive Engineers (SAE)
- American Petroleum Institute (API)
- National Lubricating Grease Institute (NLGI)

API SERVICE GRADE CERTIFIED

Use an engine oil that is API Certified (GF-3). MOPAR® provides engine oils, meeting Material Standard MS-6395, that meet or exceed this requirement.

FLUID TYPES (Continued)

SAE VISCOSITY

An SAE viscosity grade is used to specify the viscosity of engine oil. Use only engine oils with multiple viscosities such as 5W-30 or 10W-30. These are specified with a dual SAE viscosity grade which indicates the cold-to-hot temperature viscosity range. Select an engine oil that is best suited to your particular temperature range and variation (Fig. 2).

- **SAE 5W-30** engine oil is preferred. SAE 5W-30 engine oils improve low temperature starting and helps vehicle fuel economy.

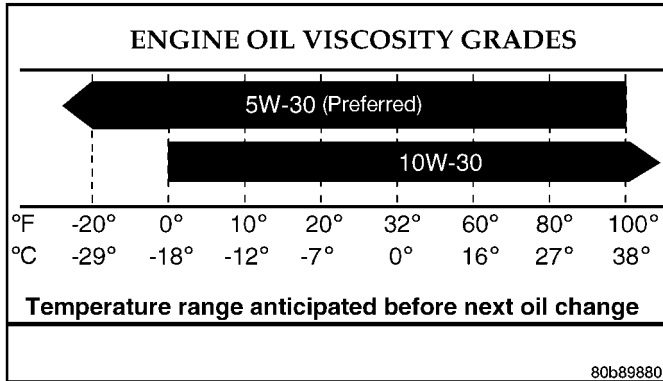

Fig. 2 TEMPERATURE/ENGINE OIL VISCOSITY

ENERGY CONSERVING OIL

An Energy Conserving type oil is recommended for gasoline engines. The designation of ENERGY CONSERVING is located on the label of an engine oil container.

CONTAINER IDENTIFICATION

Standard engine oil identification notations have been adopted to aid in the proper selection of engine oil. The identifying notations are located on the front label of engine oil plastic bottles and the top of engine oil cans (Fig. 3).

This symbol means that the oil has been certified by the American Petroleum Institute (API). Diamler-Chrysler only recommends API Certified (GF-3) engine oils that meet the requirements of Material Standard MS-6395. Use Mopar or an equivalent oil meeting the specification MS-6395.



Fig. 3 API SYMBOL

9400-9

SYNTHETIC ENGINE OILS

There are a number of engine oils being promoted as either synthetic or semi-synthetic. If you chose to use such a product, use **only** those oils that meet the American Petroleum Institute (API) and SAE viscosity standard. Follow the service schedule that describes your driving type.

MATERIALS ADDED TO ENGINE OIL

The manufacturer **does not recommend** the addition of any additive to the specified engine oil.

GEAR LUBRICANTS

SAE ratings also apply to multigrade gear lubricants. In addition, API classification defines the lubricants usage. Such as API GL-5 and SAE 75W-90.

LUBRICANTS AND GREASES

Lubricating grease is rated for quality and usage by the NLGI. All approved products have the NLGI symbol (Fig. 4) on the label. At the bottom NLGI symbol is the usage and quality identification letters. Wheel bearing lubricant is identified by the letter "G". Chassis lubricant is identified by the latter "L". The letter following the usage letter indicates the quality of the lubricant. The following symbols indicate the highest quality.

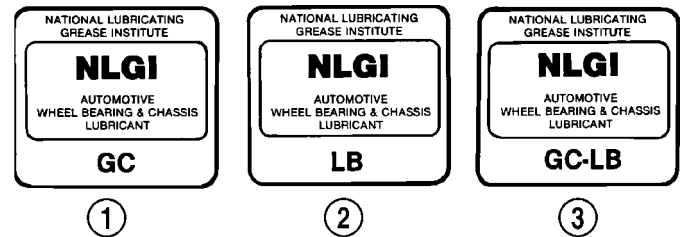

9200-7

Fig. 4 NLGI SYMBOL

- 1 - WHEEL BEARINGS
- 2 - CHASSIS LUBRICATION
- 3 - CHASSIS AND WHEEL BEARINGS

SPECIALIZED LUBRICANTS AND OILS

Some maintenance or repair procedures may require the use of specialized lubricants or oils. Consult the appropriate sections in this manual for the correct application of these lubricants.

FLUID TYPES (Continued)

DESCRIPTION - ENGINE COOLANT

WARNING: ANTIFREEZE IS AN ETHYLENE GLYCOL BASE COOLANT AND IS HARMFUL IF SWALLOWED OR INHALED. IF SWALLOWED, DRINK TWO GLASSES OF WATER AND INDUCE VOMITING. IF INHALED, MOVE TO FRESH AIR AREA. SEEK MEDICAL ATTENTION IMMEDIATELY. DO NOT STORE IN OPEN OR UNMARKED CONTAINERS. WASH SKIN AND CLOTHING THOROUGHLY AFTER COMING IN CONTACT WITH ETHYLENE GLYCOL. KEEP OUT OF REACH OF CHILDREN. DISPOSE OF GLYCOL BASE COOLANT PROPERLY, CONTACT YOUR DEALER OR GOVERNMENT AGENCY FOR LOCATION OF COLLECTION CENTER IN YOUR AREA. DO NOT OPEN A COOLING SYSTEM WHEN THE ENGINE IS AT OPERATING TEMPERATURE OR HOT UNDER PRESSURE, PERSONAL INJURY CAN RESULT. AVOID RADIATOR COOLING FAN WHEN ENGINE COMPARTMENT RELATED SERVICE IS PERFORMED, PERSONAL INJURY CAN RESULT.

CAUTION: Use of Propylene Glycol based coolants is not recommended, as they provide less freeze protection and less boiling protection.

The cooling system is designed around the coolant. The coolant must accept heat from engine metal, in the cylinder head area near the exhaust valves and engine block. Then coolant carries the heat to the radiator where the tube/fin radiator can transfer the heat to the air.

The use of aluminum cylinder blocks, cylinder heads, and water pumps requires special corrosion protection. Mopar® Antifreeze/Coolant, 5 Year/100,000 Mile Formula (MS-9769), or the equivalent ethylene glycol base coolant with hybrid organic corrosion inhibitors (called HOAT, for Hybrid Organic Additive Technology) is recommended. This coolant offers the best engine cooling without corrosion when mixed with 50% Ethylene Glycol and 50% distilled water to obtain a freeze point of -37°C (-35°F). If it loses color or becomes contaminated, drain, flush, and replace with fresh properly mixed coolant solution.

The green coolant **MUST NOT BE MIXED** with the orange or magenta coolants. When replacing coolant the complete system flush must be performed before using the replacement coolant.

CAUTION: Mopar® Antifreeze/Coolant, 5 Year/100,000 Mile Formula (MS-9769) may not be mixed with any other type of antifreeze. Doing so will reduce the corrosion protection and may result in premature water pump seal failure. If non-HOAT coolant is introduced into the cooling system in an

emergency, it should be replaced with the specified coolant as soon as possible.

DESCRIPTION - TRANSMISSION FLUID

NOTE: Refer to the maintenance schedules in the Owner's Manual for the recommended maintenance (fluid/filter change) intervals for this transaxle.

NOTE: All transaxles have a common transmission and differential sump. Filling the transaxle accommodates the differential as well.

TRANSMISSION FLUID

Mopar® ATF+4 (Automatic Transmission Fluid-Type 9602) is required in the 41TE automatic. Substitute fluids can induce torque converter clutch shudder.

Mopar® ATF+4 (Automatic Transmission Fluid-Type 9602) when new is red in color. The ATF is dyed red so it can be identified from other fluids used in the vehicle such as engine oil or antifreeze. The red color is not permanent and is not an indicator of fluid condition. As the vehicle is driven, the ATF will begin to look darker in color and may eventually become brown. **This is normal.** A dark brown/black fluid accompanied with a burnt odor and/or deterioration in shift quality may indicate fluid deterioration or transmission component failure.

G288 and T350 Manual transaxles require the use of Mopar® ATF+4 (Automatic Transmission Fluid)

FLUID ADDITIVES

DaimlerChrysler strongly recommends against the addition of any fluids to the transmission, other than those automatic transmission fluids listed above. Exceptions to this policy are the use of special dyes to aid in detecting fluid leaks.

Various "special" additives and supplements exist that claim to improve shift feel and/or quality. These additives and others also claim to improve converter clutch operation and inhibit overheating, oxidation, varnish, and sludge. These claims have not been supported to the satisfaction of DaimlerChrysler and these additives **must not be used.** The use of transmission "sealers" should also be avoided, since they may adversely affect the integrity of transmission seals.

DESCRIPTION - FUEL REQUIREMENTS

Your engine is designed to meet all emissions regulations and provide excellent fuel economy and performance when using high quality unleaded gasoline having an octane rating of 87. The use of premium gasoline is not recommended. The use of premium

FLUID TYPES (Continued)

gasoline will provide no benefit over high quality regular gasoline, and in some circumstances may result in poorer performance.

Light spark knock at low engine speeds is not harmful to your engine. However, continued heavy spark knock at high speeds can cause damage and immediate service is required. Engine damage resulting from operation with a heavy spark knock may not be covered by the new vehicle warranty.

Poor quality gasoline can cause problems such as hard starting, stalling and hesitations. If you experience these symptoms, try another brand of gasoline before considering service for the vehicle.

Over 40 auto manufacturers world-wide have issued and endorsed consistent gasoline specifications (the Worldwide Fuel Charter, WWFC) to define fuel properties necessary to deliver enhanced emissions, performance and durability for your vehicle. We recommend the use of gasolines that meet the WWFC specifications if they are available.

REFORMULATED GASOLINE

Many areas of the country require the use of cleaner burning gasoline referred to as "reformulated" gasoline. Reformulated gasoline contain oxygenates, and are specifically blended to reduce vehicle emissions and improve air quality.

We strongly support the use of reformulated gasoline. Properly blended reformulated gasoline will provide excellent performance and durability for the engine and fuel system components.

GASOLINE/OXYGENATE BLENDS

Some fuel suppliers blend unleaded gasoline with oxygenates such as 10% ethanol, MTBE, and ETBE. Oxygenates are required in some areas of the country during the winter months to reduce carbon monoxide emissions. Fuels blended with these oxygenates may be used in your vehicle.

CAUTION: DO NOT use gasoline containing METHANOL. Gasoline containing methanol may damage critical fuel system components.

MMT IN GASOLINE

MMT is a manganese-containing metallic additive that is blended into some gasoline to increase octane. Gasoline blended with MMT provide no performance advantage beyond gasoline of the same octane number without MMT. Gasoline blended with MMT reduce spark plug life and reduce emission system performance in some vehicles. We recommend that gasoline free of MMT be used in your vehicle. The MMT content of gasoline may not be indicated on the gasoline pump; therefore, you should ask your gaso-

line retailer whether or not his/her gasoline contains MMT.

It is even more important to look for gasoline without MMT in Canada because MMT can be used at levels higher than allowed in the United States. MMT is prohibited in Federal and California reformulated gasoline.

SULFUR IN GASOLINE

If you live in the northeast United States, your vehicle may have been designed to meet California low emission standards with Cleaner-Burning California reformulated gasoline with low sulfur. If such fuels are not available in states adopting California emission standards, your vehicles will operate satisfactorily on fuels meeting federal specifications, but emission control system performance may be adversely affected. Gasoline sold outside of California is permitted to have higher sulfur levels which may affect the performance of the vehicle's catalytic converter. This may cause the Malfunction Indicator Lamp (MIL), Check Engine or Service Engine Soon light to illuminate. We recommend that you try a different brand of unleaded gasoline having lower sulfur to determine if the problem is fuel related prior to returning your vehicle to an authorized dealer for service.

CAUTION: If the Malfunction Indicator Lamp (MIL), Check Engine or Service Engine Soon light is flashing, immediate service is required; see on-board diagnostics system section.

MATERIALS ADDED TO FUEL

All gasoline sold in the United States and Canada are required to contain effective detergent additives. Use of additional detergents or other additives is not needed under normal conditions.

FUEL SYSTEM CAUTIONS

CAUTION: Follow these guidelines to maintain your vehicle's performance:

- The use of leaded gas is prohibited by Federal law. Using leaded gasoline can impair engine performance, damage the emission control system, and could result in loss of warranty coverage.
- An out-of-tune engine, or certain fuel or ignition malfunctions, can cause the catalytic converter to overheat. If you notice a pungent burning odor or some light smoke, your engine may be out of tune or malfunctioning and may require immediate service. Contact your dealer for service assistance.
- When pulling a heavy load or driving a fully loaded vehicle when the humidity is low and the tem-

FLUID TYPES (Continued)

perature is high, use a premium unleaded fuel to help prevent spark knock. If spark knock persists, lighten the load, or engine piston damage may result.

- The use of fuel additives which are now being sold as octane enhancers is not recommended. Most of these products contain high concentrations of methanol. Fuel system damage or vehicle performance problems resulting from the use of such fuels or additives is not the responsibility of DaimlerChrysler Corporation and may not be covered under the new vehicle warranty.

NOTE: Intentional tampering with emissions control systems can result in civil penalties being assessed against you.

FLUID CAPACITIES

SPECIFICATIONS - FLUID CAPACITIES

DESCRIPTION	SPECIFICATION
Fuel Tank	57L (15 gal.)
Engine Oil* - 1.6L	4.3L (4.5 qts.)
Engine Oil* - 2.0L	4.3L (4.5 qts.)
Engine Oil* - 2.2L Diesel	7.0L (7.4 qts.)
Engine Oil* - 2.4L	4.8L (5.0 qts.)
Cooling System** - 1.6L, 2.0L, and 2.4L	6.2L (6.5 qts.)
Cooling System** - 2.2L Diesel	9.0L (9.5 qts.)
Automatic Transaxle - Estimated Service Fill	3.8L (4.0 qts.)
Automatic Transaxle - Overhaul Fill Capacity with Torque Converter Empty	8.1L (8.6 qts.)
Manual Transaxle - NV T350	2.4 - 2.7L (2.5 - 2.8 qts.)
Manual Transaxle - Getrag 288	2.2L Turbo Diesel: 2.0L (2.1 qts.)
	2.4L Turbo: 1.8L (1.9 qts.)
*(includes new filter)	
**(Includes heater and coolant recovery bottle filled to MAX level.)	

FLUID FILL/CHECK LOCATIONS

DESCRIPTION

The fluid check/fill point locations are located in each applicable service manual section.

LUBRICATION POINTS

DESCRIPTION

Lubrication point locations are located in each applicable Sections.

MAINTENANCE SCHEDULES

DESCRIPTION

Maintenance Schedule Information not included in this section, is located in the appropriate Owner's Manual.

There are three maintenance schedules that show **required** service for your vehicle.

First is Schedule "B"—**ALL ENGINES**. It is for vehicles that are operated under the conditions that are listed below and at the beginning of the schedule.

- Day or night temperatures are below 0° C (32° F).
- Stop and go driving.
- Extensive engine idling.
- Driving in dusty conditions.
- Short trips of less than 16 km (10 miles).
- More than 50% of your driving is at sustained high speeds during hot weather, above 32° C (90° F).†
- Trailer towing.†◇
- Taxi, police, or delivery service (commercial service).†◇
- Off-road or desert operation.
- **If equipped for and operating with E-85 (ethanol) fuel.**

NOTE: Most vehicles are operated under the conditions listed for Schedule "B".

Second is Schedule "A"—**NON TURBO CHARGED ENGINES**. It is for vehicles that are not operated under any of the conditions listed under Schedule "B"—**ALL ENGINES**.

Second is Schedule "A"—**TURBO CHARGED ENGINES**. It is for vehicles that are not operated under any of the conditions listed under Schedule "B"—**ALL ENGINES**.

Use the schedule that best describes your driving conditions. Where time and mileage are listed, follow the interval that occurs first.

MAINTENANCE SCHEDULES (Continued)

CAUTION: Failure to perform the required maintenance items may result in damage to the vehicle.

At Each Stop for Fuel

- Check the engine oil level about 5 minutes after a fully warmed engine is shut off. Checking the oil level while the vehicle is on level ground will improve the accuracy of the oil level reading. Add oil only when the level is at or below the ADD or MIN mark.
- Check the windshield washer solvent and add if required.

Once a Month

- Check tire pressure and look for unusual wear or damage.
- Inspect the battery and clean and tighten the terminals as required.
- Check the fluid levels of coolant reservoir, brake master cylinder, power steering and transaxle and add as needed.
- Check all lights and all other electrical items for correct operation.
- Check rubber seals on each side of the radiator for proper fit.

At Each Oil Change

- Change the engine oil filter.
- Inspect the exhaust system.
- Inspect the brake hoses.
- Inspect the CV joints and front suspension components.
- Check the automatic transaxle fluid level.
- Check the manual transaxle fluid level and fill plug condition.

- Check the coolant level, hoses, and clamps.
- Rotate the tires at each oil change interval shown on Schedule "A"—NON TURBO CHARGED ENGINES 10 000 km (6,000 miles), Schedule "A"—TURBO CHARGED ENGINES 8 000 km (5,000 miles), or every other interval shown on Schedule "B"—ALL ENGINES 10 000 km (6,000 miles).

SCHEDULE "B"—ALL ENGINES

Follow schedule "B"—All Engines if you usually operate your vehicle under one or more of the following conditions. Change the automatic transmission fluid and filter every 77 000 km (48,000 miles) if the vehicle is usually operated under one or more of the conditions marked with an \diamond .

Change the manual transaxle fluid every 77 000 km (48,000 miles) if the vehicle is usually operated under one or more of the conditions marked with an \dagger .

- Day or night temperatures are below 0° C (32° F).
- Stop and go driving.
- Extensive engine idling.
- Driving in dusty conditions.
- Short trips of less than 16.2 km (10 miles).
- More than 50% of your driving is at sustained high speeds during hot weather, above 32° C (90° F). \dagger
- Trailer towing. $\dagger\diamond$
- Taxi, police, or delivery service (commercial service). $\dagger\diamond$
- Off-road or desert operation.
- **If equipped for and operating with E-85 (ethanol) fuel.**

Miles (Kilometers)	3,000 (5 000)	6,000 (10 000)	9,000 (14 000)	12,000 (19 000)	15,000 (24 000)	18,000 (29 000)
Change engine oil and engine oil filter.	X	X	X	X	X	X
Inspect the brake linings.				X		
Inspect the engine air cleaner filter . Replace as necessary.*					X	
Inspect the PCV make-up air filter . Replace as necessary.					X	
Inspect the generator belt, and replace as necessary.					X	
Inspect and adjust the power steering pump belt tension.					X	

MAINTENANCE SCHEDULES (Continued)

Miles (Kilometers)	21,000 (34 000)	24,000 (38 000)	27,000 (43 000)	30,000 (48 000)	33,000 (53 000)	36,000 (58 000)
Change engine oil and engine oil filter.	X	X	X	X	X	X
Inspect the brake linings.		X				X
Replace the engine air cleaner filter .				X		
Replace the spark plugs .				X		
Inspect the tie rod ends and boot seals.				X		
Inspect the PCV valve and replace as necessary.*				X		
Replace the PCV make-up air filter .				X		
Inspect and adjust the power steering pump belt tension.				X		
Inspect the generator belt, and replace as necessary.				X		

Miles (Kilometers)	39,000 (62 000)	42,000 (67 000)	45,000 (72 000)	48,000 (77 000)	51,000 (82 000)	54,000 (86 000)
Change engine oil and engine oil filter.	X	X	X	X	X	X
Inspect the brake linings.				X		
Change the brake fluid. If vehicle is used for trailer towing.				X		
Inspect the engine air cleaner filter . Replace as necessary.*			X			
Change the automatic transaxle fluid and filter.				X		
Change the manual transaxle fluid.				X		
Inspect the PCV make-up air filter . Replace as necessary.			X			
Inspect and adjust the power steering pump belt tension.			X			
Inspect the generator belt, and replace as necessary.			X			

MAINTENANCE SCHEDULES (Continued)

Miles (Kilometers)	57,000 (91 000)	60,000 (96 000)	63,000 (101 000)	66,000 (106 000)	69,000 (110 000)	72,000 (115 000)
Change engine oil and engine oil filter.	X	X	X	X	X	X
Inspect the brake linings.		X				X
Replace the engine air cleaner filter .		X				
Replace the spark plugs and ignition cables .		X				
Inspect the tie rod ends and boot seals.		X				
Inspect the PCV valve and replace if necessary. Not required if previously changed. * ‡		X				
Inspect the PCV make-up air filter . Replace as necessary.		X				
Inspect and adjust the power steering pump belt tension.		X				
Inspect the generator belt, and replace as necessary.		X				

Miles (Kilometers)	75,000 (120 000)	78,000 (125 000)	81,000 (130 000)	84,000 (134 000)	87,000 (139 000)	90,000 (144 000)
Change engine oil and engine oil filter.	X	X	X	X	X	X
Inspect the brake linings.				X		
Inspect the engine air cleaner filter and replace as necessary.*	X					
Replace the engine air cleaner filter .						X
Replace the spark plugs .						X
Inspect the tie rod ends and boot seals.						X
Inspect the PCV valve and replace if necessary. Not required if previously changed. * ‡						X
Replace the engine timing belt .*						X
Inspect the PCV make-up air filter . Replace as necessary.	X					X
Inspect and adjust the power steering pump belt tension.	X					X
Inspect the generator belt, and replace as necessary.	X					X