



# Service Manual

## Chassis & Mast

|                |                |               |                |
|----------------|----------------|---------------|----------------|
| <b>P30001</b>  | AT34-10121-up  | <b>P40001</b> | AT18C-10121-up |
| <b>P35001</b>  | AT34-10121-up  | <b>P50001</b> | AT18C-10121-up |
| <b>PC40001</b> | AT34-60121-up  | <b>P55001</b> | AT37-10121-up  |
| <b>P40001</b>  | AT35-10121-up  | <b>P60001</b> | AT14E-10121-up |
| <b>P50001</b>  | AT35-10121-up  | <b>P65001</b> | AT14E-60121-up |
| <b>P55001</b>  | AT36-10121-up  | <b>P70001</b> | AT14E-60121-up |
| <b>P60001</b>  | AT13F-10121-up |               |                |
| <b>P65001</b>  | AT13F-60121-up |               |                |
| <b>P70001</b>  | AT13F-60121-up |               |                |

For use with K21/K25 and S4S Engine Service Manuals.

99719-89120



## FOREWORD

This service manual is a guide for servicing Cat® Lift Trucks. For your convenience the instructions are grouped by systems as a ready reference.

Long productive life of your lift truck(s) depends on regular and proper servicing. Servicing consistent with what you will learn by reading this service manual. Read the respective sections of this manual carefully and familiarize yourself with all of the components before attempting to start a test, repair or rebuild job.

The descriptions, illustrations and specifications contained in this manual are for trucks with serial numbers in effect at the time of printing. Cat Lift Trucks reserves the right to change specifications or design without notice and without incurring obligation.

The trucks listed in this manual are powered by K21/K25 gasoline engines or S4S diesel engines. For the engine servicing, please refer to the applicable engine service manual.

### Safety Related Signs

The following safety related signs are used in this service manual to emphasize important and critical instructions:

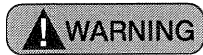

Indicate a potentially hazardous situation which, if not avoided, could result in death or serious injury.

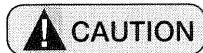

Indicate a potentially hazardous situation which, if not avoided, may result in minor or moderate injury, or damage to your machine.

(NOTE)

Indicates a condition that can cause damage to, or shorten service life of, the machine.

 **WARNING**

## SAFETY

 **WARNING**

The proper and safe lubrication and maintenance for these lift trucks, recommended by Cat Lift Trucks, are outlined in the OPERATION & MAINTENANCE MANUAL. Improper performance of lubrication or maintenance procedures is dangerous and could result in injury or death. Read and understand the OPERATION & MAINTENANCE MANUAL before performing any lubrication or maintenance on these trucks.

The serviceman or mechanic may be unfamiliar with many of the systems on this truck. This makes it important to use caution when performing service work. A knowledge of the system and/or components is important before the removal or disassembly of any component.

Because of the size of some of the truck components, the serviceman or mechanic should check the weights noted in this Manual. Use proper lifting procedures when removing any components.

Following is a list of basic precautions that should always be observed.

1. Read and understand all warning plates and decals on the truck before operating, lubricating or repairing the product.
2. Always wear protective glasses and protective shoes when working around trucks. In particular, wear protective glasses when pounding on any part of the truck or its attachments with a hammer or sledge. Use welders gloves, hood/goggles, apron and other protective clothing appropriate to the welding job being performed. Do not wear loose-fitting or torn clothing. Remove all rings from fingers when working on machinery.
3. Do not work on any truck that is supported only by lift jacks or a hoist. Always use blocks or jack stands to support the truck before performing any disassembly.

 **WARNING**

Do not operate these trucks unless you have read and understood the instructions in the OPERATION & MAINTENANCE MANUAL. Improper truck operation is dangerous and could result in injury or death.

4. Lower the forks or other implements to the ground before performing any work on the truck. If this cannot be done, make sure the forks or other implements are blocked correctly to prevent them from dropping unexpectedly.
5. Use steps and grab handles (if applicable) when mounting or dismounting a truck. Clean any mud or debris from steps, walkways or work platforms before using. Always face truck when using steps, ladders and walkways. When it is not possible to use the designed access system, provide ladders, scaffolds, or work platforms to perform safe repair operations.
6. To avoid back injury, use a hoist when lifting components which weigh 23 kg (50 lb.) or more. Make sure all chains, hooks, slings, etc., are in good condition and are of the correct capacity. Be sure hooks are positioned correctly. Lifting eyes are not to be side loaded during a lifting operation.
7. To avoid burns, be alert for hot parts on trucks which have just been stopped and hot fluids in lines, tubes and compartments.
8. Be careful when removing cover plates. Gradually back off the last two bolts or nuts located at opposite ends of the cover or device and pry cover loose to relieve any spring or other pressure, before removing the last two bolts or nuts completely.
9. Be careful when removing filler caps, breathers and plugs on the truck. Hold a rag over the cap or plug to prevent being sprayed or splashed by liquids under pressure. The danger is even greater if the truck has just been stopped because fluids can be hot.

10. Always use tools that are in good condition and be sure you understand how to use them before performing any service work.
11. Reinstall all fasteners with same part number. Do not use a lesser quality fastener if replacements are necessary.
12. If possible, make all repairs with the truck parked on a level, hard surface. Block truck so it does not roll while working on or under truck.
13. Disconnect battery and discharge any capacitors (electric trucks) before starting to work on truck. Hang "Do not Operate" tag in the Operator's Compartment.
14. Repairs, which require welding, should be performed only with the benefit of the appropriate reference information and by personnel adequately trained and knowledgeable in welding procedures. Determine type of metal being welded and select correct welding procedure and electrodes, rods or wire to provide a weld metal strength equivalent at least to that of parent metal.
15. Do not damage wiring during removal operations. Reinstall the wiring so it is not damaged nor will it be damaged in operation by contacting sharp corners, or by rubbing against some object or hot surface. Place wiring away from oil pipe.
16. Be sure all protective devices including guards and shields are properly installed and functioning correctly before starting a repair. If a guard or shield must be removed to perform the repair work, use extra caution.
17. Always support the mast and carriage to keep carriage or attachments raised when maintenance or repair work is performed, which requires the mast in the raised position.
18. Loose or damaged fuel, lubricant and hydraulic lines, tubes and hoses can cause fires. Do not bend or strike high pressure lines or install ones which have been bent or damaged. Inspect lines, tubes and hoses carefully. Do not check for leaks with your hands. Pin hole (very small) leaks can result in a high velocity oil stream that will be invisible close to the hose. This oil can penetrate the skin and cause personal injury. Use cardboard or paper to locate pin hole leaks.
19. Tighten connections to the correct torque. Make sure that all heat shields, clamps and guards are installed correctly to avoid excessive heat, vibration or rubbing against other parts during operation. Shields that protect against oil spray onto hot exhaust components in event of a line, tube or seal failure, must be installed correctly.
20. Relieve all pressure in air, oil or water systems before any lines, fittings or related items are disconnected or removed. Always make sure all raised components are blocked correctly and be alert for possible pressure when disconnecting any device from a system that utilizes pressure.
21. Do not operate a truck if any rotating part is damaged or contacts any other part during operation. Any high speed rotating component that has been damaged or altered should be checked for balance before reusing.

# HOW TO USE THIS MANUAL (Removal, Installation, Assembly and Disassembly)

Disassembly diagram (example)

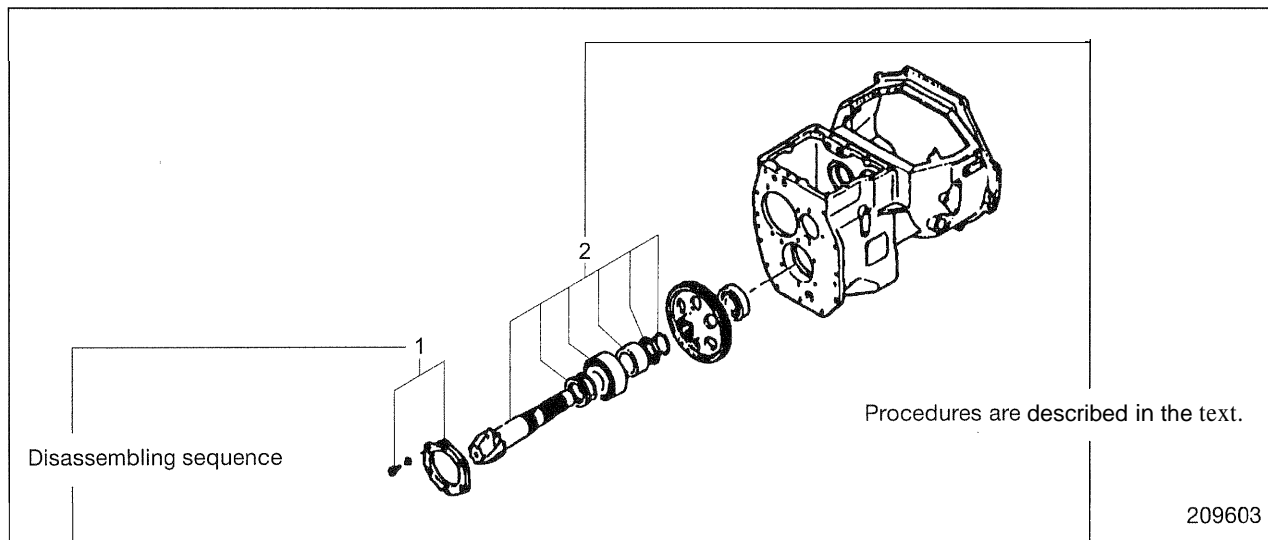

**Sequence**

- 1 Cover, Bolt, Washer (part name)
- 2 Snap ring ..... (part name)

**Suggestion for disassembling**

- 1. Output shaft, Removing  
Remove output shaft using a special tool.

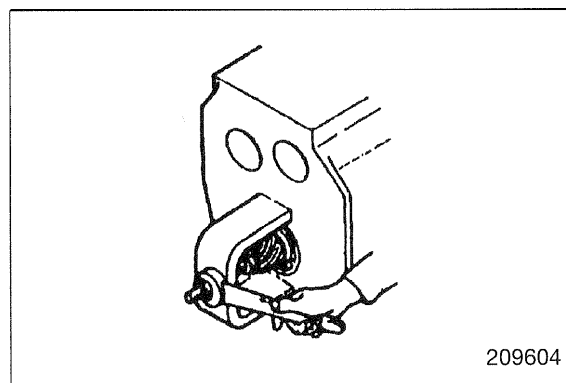

**Service Data**

|               |   |   |
|---------------|---|---|
| Gear Backlash | A | 0.11 to 0.28 mm<br>(0.0043 to 0.0110 in.) |
|               | B | 0.5 mm (0.020 in.)                        |

A: Standard Value  
B: Repair or Service Limit'

## Symbols or abbreviation

|       |   |
|-------|---|
| OP    | Option  |
| R1/4  | Taper pipe thread (external) 1/4 inch (formerly PT1/4)      |
| Rc1/8 | Taper pipe thread (internal) 1/8 inch (formerly PT1/8)      |
| G1/4A | Straight pipe thread (external) 1/4 inch (formerly PF1/4-A) |
| Rp1/8 | Straight pipe thread (internal) 1/8 inch (formerly PS1/8)   |

## Units

1. SI Units are used in this manual.
2. The following table shows the conversion of SI unit and customary unit.

| Item     | SI unit | Customary unit             |
|----------|---------|----------------------------|
| Force    | 1 N     | 0.1012 kgf                 |
| Pressure | 1 kPa   | 0.0102 kgf/cm <sup>2</sup> |
| Torque   | 1 N·m   | 0.1012 kfg·m               |





# GROUP INDEX

| GROUP INDEX                           | Items  |
|---------------------------------------|--|
| GENERAL INFORMATION                   | Model view, Truck models covered, Serial number locations, Dimensions, Technical data                              |
| COOLING SYSTEM                        | Fan removal and installation, Fan belt inspection and adjustment   |
| ELECTRICAL SYSTEM                     | Console box, Chassis electrical devices, Battery maintenance, Electrical system schematic                          |
| CONTROLLERS                           | Main functions, Service tool functions, Input/output monitor, Error codes and troubleshooting                      |
| POWER TRAIN                           | Removal and installation   |
| POWERSHIFT TRANSMISSION               | Torque converter, 1-speed transmission, Control valve, Automatic 2-speed transmission                              |
| FRONT AXLE AND REDUCTION DIFFERENTIAL | Front tires, Front axle, Reduction and differential  |
| REAR AXLE                             | Rear tires, Rear axle, Toe-in, Minimum turning radius  |
| BRAKE SYSTEM                          | Master cylinder, Wheel cylinders, Wheel brakes, Brake booster  |
| STEERING SYSTEM                       | Steering gear, Power cylinder, Flow divider  |
| HYDRAULIC SYSTEM                      | Hydraulic tank, Gear pump, Control valve, Lift and tilt cylinders, Flow regulator valve, Down safety valve         |
| MAST AND FORKS                        | Simplex mast, Duplex mast, Triplex mast  |
| SERVICE DATA                          | Maintenance standards, Periodic service chart, Periodic replacement parts, Lubrication instructions, Special tools |

**1**

**2**

**3**

**4**

**5**

**6**

**7**

**8**

**9**

**10**

**11**

**12**

**13**

# GENERAL INFORMATION

Model View ..... 1 - 1

Truck Models Covered ..... 1 - 2

Serial Number Locations ..... 1 - 3

Dimensions ..... 1 - 4

Technical Data ..... 1 - 5



**Model View**

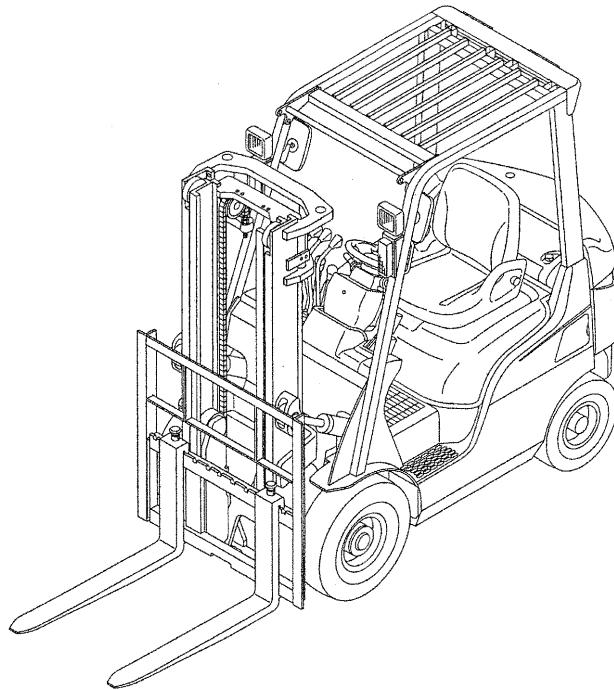

209605

## Truck Models Covered

This Service Manual contains servicing and maintenance information for the following trucks:

| Truck class | Gasoline-engine models |                |                | Dual fuel gasoline-engine models |                |                |
|-------------|------------------------|----------------|----------------|----------------------------------|----------------|----------------|
|             | Truck model            | Serial number  | Engine mounted | Truck model                      | Serial number  | Engine mounted |
| 1 ton class | P30001                 | AT34-10121-up  | K21            | P30001                           | AT34-10121-up  | K21            |
|             | P35001                 | AT34-10121-up  | K21            | P35001                           | AT34-10121-up  | K21            |
|             | PC40001                | AT34-60121-up  | K21            | PC40001                          | AT34-60121-up  | K21            |
| 2 ton class | P40001                 | AT35-10121-up  | K25            | P40001                           | AT35-10121-up  | K25            |
|             | P50001                 | AT35-10121-up  | K25            | P50001                           | AT35-10121-up  | K25            |
|             | P55001                 | AT36-10121-up  | K25            | P55001                           | AT36-10121-up  | K25            |
| 3 ton class | P60001                 | AT13F-10121-up | K25            | P60001                           | AT13F-10121-up | K25            |
|             | P65001                 | AT13F-60121-up | K25            | P65001                           | AT13F-60121-up | K25            |
|             | P70001                 | AT13F-60121-up | K25            | P70001                           | AT13F-60121-up | K25            |

| Truck class | LPG-engine models |                |                | Diesel-engine models |                |                |
|-------------|-------------------|----------------|----------------|----------------------|----------------|----------------|
|             | Truck model       | Serial number  | Engine mounted | Truck model          | Serial number  | Engine mounted |
| 1 ton class | P30001            | AT34-10121-up  | K21            | —                    | —              | —              |
|             | P35001            | AT34-10121-up  | K21            |                      |                |                |
|             | PC40001           | AT34-60121-up  | K21            |                      |                |                |
| 2 ton class | P40001            | AT35-10121-UP  | K25            | P40001               | AT18C-10121-up | S4S            |
|             | P50001            | AT35-10121-up  | K25            | P50001               | AT18C-10121-up | S4S            |
|             | P55001            | AT36-10121-up  | K25            | P55001               | AT37-10121-up  | S4S            |
| 3 ton class | P60001            | AT13F-10121-up | K25            | P60001               | AT14E-10121-up | S4S            |
|             | P65001            | AT13F-60121-up | K25            | P65001               | AT14E-60121-up | S4S            |
|             | P70001            | AT13F-60121-up | K25            | P70001               | AT14E-60121-up | S4S            |

Note: Characters at the end of truck model should be read as follows:

C: Short body model

# Serial Number Locations

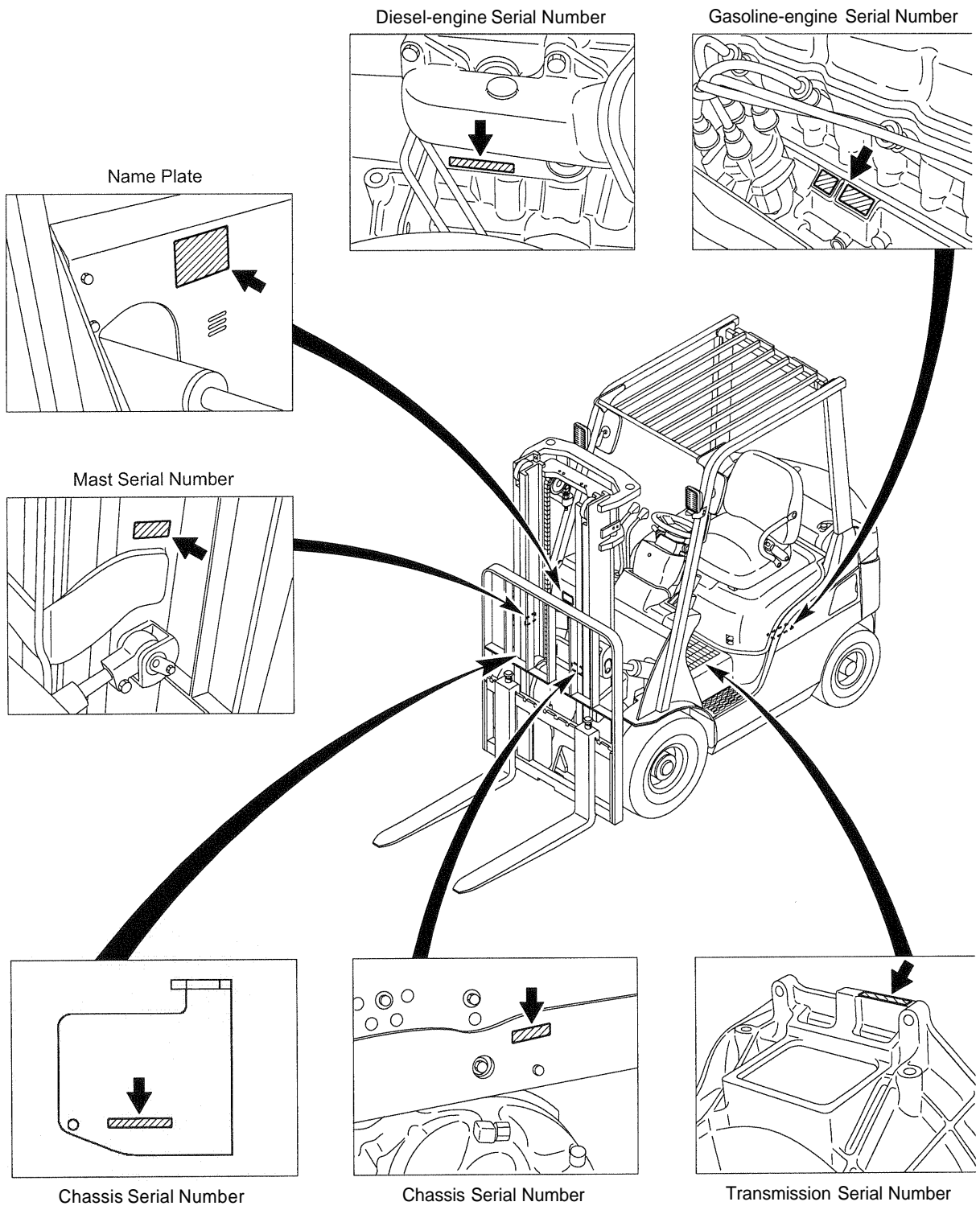

210066

**Dimensions**

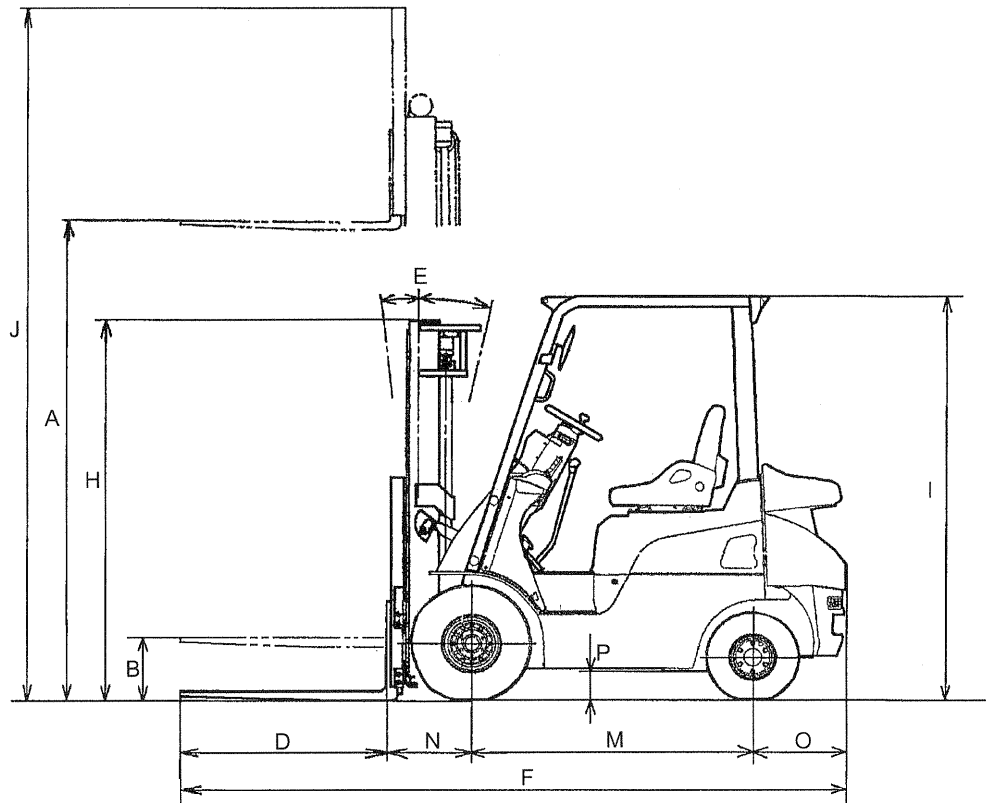
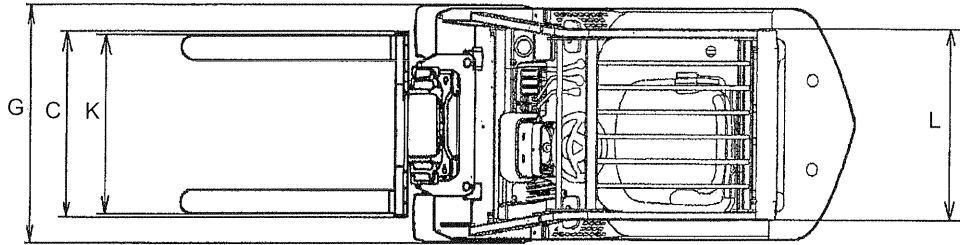

## Technical Data

Unit: mm (in.)

| Ref. No. | Model                                     | Gasoline-engine Truck    | P30001       | P35001       | PC40001                   |
|----------|---|--------------------------|--------------|--------------|---------------------------|
|          |   | Diesel-engine Truck      |              |              |                           |
| Item     |   |                          |              |              |                           |
| A        | Maximum lift                              | 3000 (118)               |              |              |                           |
| B        | Free lift                                 | 115 (4.5)                |              |              |                           |
| C        | Fork spread (outside)                     | 200 to 920 (7.9 to 36.2) |              |              | 220 to 1000 (8.7 to 39.4) |
| D        | Fork length                               | 920 (36.2)               |              |              |                           |
| E        | Tilt angle (forward – backward)           | 6° – 12°                 |              |              |                           |
| F        | Overall length                            | 3180 (125.2)             | 3321 (126.8) | 3279 (129.1) |                           |
| G        | Overall width (outside of tires)          | Single tire              | 1065 (41.9)  |              |                           |
|          |   | Dual tire                | 1330 (52.4)  |              | —                         |
| H        | Overall height (to top of mast lowered)   | 1995 (78.5)              |              |              |                           |
| I        | Overall height (to top of overhead guard) | 2065 (81.3)              |              |              |                           |
| J        | Overall height (mast extended)            | 4055 (159.6)             |              |              |                           |
| K        | Tread (front)                             | Single tire              | 890 (35)     |              |                           |
|          |   | Dual tire                | 1025 (40.4)  |              | —                         |
| L        | Tread (rear)                              | 900 (35.4)               |              |              |                           |
| M        | Wheelbase                                 | 1400 (55.1)              |              |              |                           |
| N        | Front overhang                            | 400 (15.7)               |              |              | 415 (16.3)                |
| O        | Rear overhang                             | 460 (18.1)               | 501 (19.7)   | 544 (21.4)   |                           |
| P        | Underclearance (at frame)                 | 150 (5.9)                |              |              |                           |



GENERAL INFORMATION

Unit: mm (in.)

| P40001                    | P50001       | P55001                    | P60001       | P65001       | P70001       |
|---------------------------|--------------|---------------------------|--------------|--------------|--------------|
| P40001                    | P50001       | P55001                    | P60001       | P65001       | P70001       |
| 3000 (118)                |              |                           |              |              |              |
| 140 (5.5)                 |              | 150 (5.9)                 |              |              |              |
| 220 to 1000 (8.7 to 39.4) |              | 250 to 1000 (9.8 to 39.4) |              |              |              |
| 920 (36.2)                | 1070 (42)    |                           |              |              |              |
| 6° – 12°                  |              |                           |              |              |              |
| 3408 (134.3)              | 3625 (142.8) | 3720 (146.6)              | 3795 (149.5) | 3827 (150.8) | 3860 (152.1) |
| 1150 (45.3)               |              | 1275 (50.2)               |              | 1290 (50.8)  |              |
| 1480 (58.3)               |              | 1490 (58.7)               |              |              |              |
| 1995 (78.5)               |              | 2045 (80.6)               |              | 1280 (50.4)  |              |
| 2070 (81.6)               |              | 2095 (82.5)               |              | 2105 (82.9)  |              |
| 4055 (159.8)              |              | 4085 (160.9)              |              | 4055 (159.8) |              |
| 960 (37.8)                |              | 1060 (41.8)               |              |              |              |
| 1140 (44.9)               |              |                           |              |              |              |
| 980 (38.6)                |              |                           |              |              |              |
| 1600 (63)                 |              | 1620 (63.8)               | 1700 (67)    |              |              |
| 455 (117.9)               |              | 490 (19.3)                |              |              |              |
| 433 (17)                  | 500 (19.7)   | 540 (21.3)                | 535 (21)     | 567 (22.3)   | 600 (23.6)   |
| 160 (6.3)                 |              | 190 (7.5)                 |              | 200 (7.9)    |              |

# COOLING SYSTEM

|                                 |       |
|---------------------------------|-------|
| Specification .....             | 2 - 1 |
| Structure .....                 | 2 - 2 |
| Removal and Installation .....  | 2 - 3 |
| Inspection and Adjustment ..... | 2 - 5 |
| Fan Belt Inspection .....       | 2 - 5 |
| Fan Belt Tension .....          | 2 - 5 |
| Connecting Radiator Hoses ..... | 2 - 5 |
| Unit Layout .....               | 2 - 5 |
| Coolant .....                   | 2 - 6 |
| Radiator Cap .....              | 2 - 6 |



**Specification**

| Items          |            | Truck Models                     | 1 ton class | 2 ton class | 3 ton class |
|----------------|------------|----------------------------------|-------------|-------------|-------------|
|                |            |                                  |             |             |             |
| Cooling System | Type       | Water-cooled, forced circulation |             |             |             |
|                | Radiator   | Corrugated fin (pressure) type   |             |             |             |
|                | Water pump | Centrifugal type                 |             |             |             |
|                | Thermostat | Wax Pellet Type                  |             |             |             |