

62IF
72IF
Tier 4

Wheel Loader

from PIN NBF213602 and above

SERVICE MANUAL

Part number 84605841

1st edition English

May 2012



Contents

INTRODUCTION

Engine.....	10
Engine and crankcase.....	10.001
Air cleaners and lines.....	10.202
Engine lubrication system	10.304
Aftercooler.....	10.310
Engine cooling system	10.400
Fan and drive.....	10.414
Selective Catalytic Reduction (SCR) exhaust treatment	10.500
Engine generic sub-group	10.AAA
Transmission.....	21
Powershift transmission	21.113
Powershift transmission external controls	21.135
Powershift transmission internal components.....	21.155
Four-Wheel Drive (4WD) system	23
Drive shaft.....	23.314
Front axle system	25
Powered front axle	25.100
Front bevel gear set and differential.....	25.102
Final drive hub, steering knuckles, and shafts	25.108
Rear axle system.....	27
Powered rear axle	27.100
Rear bevel gear set and differential	27.106
Planetary and final drives.....	27.120
Brakes and controls	33
Hydraulic service brakes	33.202
Hydraulic systems.....	35

Hydraulic systems	35.000
Variable displacement pump	35.106
Pilot system.....	35.357
Main control valve	35.359
Auxiliary hydraulic valves and lines	35.525
Front loader arm hydraulic system	35.701
Steering.....	41
Auxiliary steering	41.910
Wheels	44
Front wheels.....	44.511
Cab climate control	50
Air conditioning	50.200
Electrical systems	55
Electrical system	55.000
Fuel tank system	55.011
Engine cooling system	55.012
Engine control system.....	55.015
Service brake electrical system	55.030
Parking brake electrical system	55.031
Hydraulic system control	55.036
Steering control system	55.047
Heating, Ventilation, and Air-Conditioning (HVAC) control system.....	55.050
Cab Heating, Ventilation, and Air-Conditioning (HVAC) controls.....	55.051
Harnesses and connectors	55.100
Engine starting system	55.201
Cold start aid	55.202
Alternator	55.301
Battery.....	55.302
External lighting	55.404

External lighting switches and relays	55.405
Warning indicators, alarms, and instruments	55.408
Loader arm and bucket control system	55.415
Cab/Platform harnesses and connectors	55.510
Cab controls	55.512
Cab lighting	55.514
Wiper/Washer system	55.518
Cab brake controls	55.519
Cab controls (Lift arm, Boom, Dipper, Bucket)	55.524
Selective Catalytic Reduction (SCR) electrical system	55.988
FAULT CODES	55.DTC
Platform, cab, bodywork, and decals	90
Pneumatically-adjusted operator seat	90.124
Cab	90.150



INTRODUCTION

Contents

INTRODUCTION

Torque – 621F Torque Specifications 3 621F WE, 621F NA	3
Torque – 721F Torque Specifications 5 721F WE, 721F NA	5
Capacities 7 621F WE, 621F NA, 721F WE, 721F NA	7
Consumables - Biodiesel Fuel 12	12
Hydraulic contamination 13	13

Torque – 621F Torque Specifications

621F WE, 621F NA

Axle

Wheel mounting nuts	640 - 720 N·m (472 - 531 lb ft)
Front axle mounting bolts	651 - 678 N·m (480 - 500 lb ft)
Rear axle trunnion pin bolts	325 - 353 N·m (240 - 260 lb ft)

Chassis

Cab mounts	773 - 854 N·m (570 - 630 lb ft)
Exhaust stack to hood	36 - 44 N·m (27 - 32 lb ft)
Counterweight mounting bolts	955 - 1075 N·m (704 - 793 lb ft)
Articulation pivot pin bolts	224 - 278 N·m (165 - 205 lb ft)
Articulation mount pin retainer bolts	69 N·m (51 lb ft)
Seat mounting bolts	73 - 87 N·m (54 - 64 lb ft)
Steering wheel retaining nut	50 N·m (37 lb ft)
Hydraulic oil filter mounting bolts	23 - 27 N·m (17 - 20 lb ft)
Steering cylinder base end pin retaining bolt	290 - 375 N·m (214 - 277 lb ft)
Steering cylinder rod end pin retaining bolt	Bolts must turn freely
Horn mounting bolt	53 - 62 N·m (39 - 46 lb ft)
Hood - rear grill bolts	9 - 11 N·m (7 - 8 lb ft)
Hood hinge bolts	65 - 79 N·m (48 - 58 lb ft)
Steps - lower entry strap bolts	27 - 31 N·m (20 - 23 lb ft)

Cooling

Fan to fan hub	40 - 48 N·m (30 - 35 lb ft)
Fan hub to motor shaft (no impact tools)	67 - 74 N·m (49 - 55 lb ft)
Radiator hose clamps	10.1 - 11.3 N·m (7.4 - 8.3 lb ft)
Hydraulic tank cover nuts	14 - 18 N·m (10 - 13 lb ft)
Hydraulic tank sight gauge	2.7 - 5.5 N·m (2.0 - 4.1 lb ft)

Diesel Exhaust Fluid (DEF) System

Heater valve bolts	17 - 19 N·m (13 - 14 lb ft)
Dosing module bolts	7 - 8 N·m (58 - 68 lb in)
DEF control module/pump assembly mounting bolts	20 - 28 N·m (15 - 21 lb ft)

Driveshafts

Coupling to flywheel	53 - 62 N·m (39 - 46 lb ft)
Driveshaft to coupling	53 - 62 N·m (39 - 46 lb ft)
Front driveshaft yoke nut	339 - 373 N·m (250 - 275 lb ft)
Carrier bearing mounting bolts	99 - 128 N·m (73 - 94 lb ft)
550R U-joints	75 - 81 N·m (55 - 60 lb ft)
410R U-joints	61 - 81 N·m (45 - 60 lb ft)
Dust cover mounting bolts	20 - 27 N·m (15 - 20 lb ft)

INTRODUCTION

Engine

Engine mounting brackets	118 - 133 N·m (87 - 98 lb ft)
Engine rubber isolator mounts (Qty 4)	244 - 298 N·m (180 - 220 lb ft)
Brake pump to engine mounting	57 - 65 N·m (42 - 48 lb ft)
Brake pump gear nut (no impact tools)	70 - 79 N·m (52 - 58 lb ft)
Turbo to turbo exhaust elbow clamp	5 N·m (4 lb ft)
Muffler to turbo elbow exhaust clamp	20 - 25 N·m (15 - 18 lb ft)
Front muffler bracket to engine block	118 - 133 N·m (87 - 98 lb ft)
Muffler brackets to muffler	114 - 128 N·m (84 - 94 lb ft)
Charge Air Cooler (CAC) hose clamps (Qty 8)	10.1 - 11.3 N·m (7.4 - 8.3 lb ft)
Air cleaner to turbo hose clamp	10.1 - 11.3 N·m (7.4 - 8.3 lb ft)
Alternator pulley (no impact tools)	60 - 70 N·m (44 - 52 lb ft)
Starter mounting nuts	40 - 50 N·m (30 - 37 lb ft)

Loader

XT loader linkage bolts	650 - 732 N·m (479 - 540 lb ft)
XT guide link nuts	240 - 305 N·m (177 - 225 lb ft)
Loader link pin keeper	325 - 373 N·m (240 - 275 lb ft)

Transmission

Transmission rubber isolator mounts (Qty 3)	890 - 1000 N·m (656 - 738 lb ft)
Transmission upper mounting bracket bolts	251 - 319 N·m (185 - 235 lb ft)
Transmission lower mounting bracket bolts (Qty 2)	481 - 590 N·m (355 - 435 lb ft)
Hydraulic pump to transmission mounting	335 - 375 N·m (247 - 277 lb ft)
Cooler clamps	10.1 - 11.3 N·m (7.4 - 8.3 lb ft)
Hydraulic pump suction hose clamp flange	73 - 90 N·m (54 - 66 lb ft)
Steering priority manifold to pump	37 - 48 N·m (27 - 35 lb ft)
Transmission fill tube bolts	17 - 33 N·m (13 - 24 lb ft)
Transmission sight gauge bolts	2.7 - 5.5 N·m (2 - 4 lb ft)

Wheels

Wheel nuts	Initial torque: 298 N·m (220 lb ft) Final torque: 640 - 720 N·m (472 - 531 lb ft)
------------	--

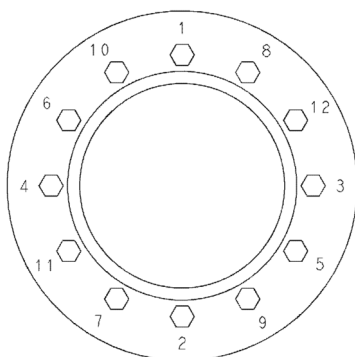

RCPH10WHL320AAH 1

Do the following initial and final torque procedures:

1. Tighten wheel nuts to an initial torque of **298 N·m (220 lb ft)** in sequence shown in figure
2. Tighten wheel nuts to a final torque of **640 - 720 N·m (472 - 531 lb ft)** in sequence shown in figure

Torque – 721F Torque Specifications

721F WE, 721F NA

Axle

Wheel mounting bolts	640 - 720 N·m (472 - 531 lb ft)
Front axle mounting bolts	765 - 855 N·m (564 - 631 lb ft)
Rear axle trunnion pin bolts	651 - 678 N·m (480 - 500 lb ft)

Chassis

Cab mounts	773 - 854 N·m (570 - 630 lb ft)
Exhaust stack to hood	36 - 44 N·m (27 - 32 lb ft)
Counterweight mounting bolts	955 - 1075 N·m (704 - 793 lb ft)
Articulation pivot pin bolts	224 - 278 N·m (165 - 205 lb ft)
Articulation mount pin retainer bolts	69 N·m (51 lb ft)
Seat mounting bolts	73 - 87 N·m (54 - 64 lb ft)
Steering wheel retaining nut	50 N·m (37 lb ft)
Hydraulic oil filter mounting bolts	23 - 27 N·m (17 - 20 lb ft)
Steering cylinder base end pin retaining bolt	290 - 375 N·m (214 - 277 lb ft)
Steering cylinder rod end pin retaining bolt	Bolts must turn freely
Horn mounting bolt	53 - 62 N·m (39 - 46 lb ft)
Hood - rear grill bolts	9 - 11 N·m (7 - 8 lb ft)
Hood hinge bolts	65 - 79 N·m (48 - 58 lb ft)
Steps - lower entry strap bolts	27 - 31 N·m (20 - 23 lb ft)

Cooling

Fan to fan hub	40 - 48 N·m (30 - 35 lb ft)
Fan hub to motor shaft (no impact tools)	67 - 74 N·m (49 - 55 lb ft)
Radiator hose clamps	10.1 - 11.3 N·m (7.4 - 8.3 lb ft)
Hydraulic tank cover nuts	14 - 18 N·m (10 - 13 lb ft)
Hydraulic tank sight gauge	2.7 - 5.5 N·m (2.0 - 4.1 lb ft)

Diesel Exhaust Fluid (DEF) System

Heater valve bolts	17 - 19 N·m (13 - 14 lb ft)
Dosing module bolts	7 - 8 N·m (58 - 68 lb in)
DEF control module/pump assembly mounting bolts	20 - 28 N·m (15 - 21 lb ft)

Driveshafts

Coupling to flywheel	53 - 62 N·m (39 - 46 lb ft)
Driveshaft to coupling	53 - 62 N·m (39 - 46 lb ft)
Front driveshaft yoke nut	339 - 373 N·m (250 - 275 lb ft)
Carrier bearing mounting bolts	99 - 128 N·m (73 - 94 lb ft)
550R U-joints	75 - 81 N·m (55 - 60 lb ft)
Dust cover mounting bolts	20 - 27 N·m (15 - 20 lb ft)
Flex plate to flywheel bolts	33 - 41 N·m (24 - 30 lb ft)
Carrier bearing bolt	150 - 164 N·m (111 - 121 lb ft)
Drive line mounting bolts	136 - 149 N·m (100 - 110 lb ft)

INTRODUCTION

Engine

Engine mounting brackets	118 - 133 N·m (87 - 98 lb ft)
Engine rubber isolator mounts (Qty 4)	244 - 298 N·m (180 - 220 lb ft)
Brake pump to engine mounting	57 - 65 N·m (42 - 48 lb ft)
Brake pump gear nut (no impact tools)	70 - 79 N·m (52 - 58 lb ft)
Turbo to turbo exhaust elbow clamp	5 N·m (4 lb ft)
Muffler to turbo elbow exhaust clamp	20 - 25 N·m (15 - 18 lb ft)
Muffler bracket to muffler	114 - 128 N·m (84 - 94 lb ft)
Charge Air Cooler (CAC) hose clamps (Qty 8)	10.1 - 11.3 N·m (7.4 - 8.3 lb ft)
Air cleaner to turbo hose clamp	10.1 - 11.3 N·m (7.4 - 8.3 lb ft)
Alternator pulley (no impact tools)	60 - 70 N·m (44 - 52 lb ft)
Starter mounting nuts	40 - 50 N·m (30 - 37 lb ft)

Loader

XT loader linkage bolts	650 - 732 N·m (479 - 540 lb ft)
XT guide link nuts	240 - 305 N·m (177 - 225 lb ft)
Loader link pin keeper	325 - 373 N·m (240 - 275 lb ft)

Transmission

Transmission rubber isolator mounts (Qty 3)	890 - 1000 N·m (656 - 738 lb ft)
Transmission upper mounting bracket bolts	251 - 319 N·m (185 - 235 lb ft)
Transmission lower mounting bracket bolts (Qty 2)	481 - 590 N·m (355 - 435 lb ft)
Cooler clamps	10.1 - 11.3 N·m (7.4 - 8.3 lb ft)
Hydraulic pump suction hose clamp flange	73 - 90 N·m (54 - 66 lb ft)
Steering priority manifold to pump	37 - 48 N·m (27 - 35 lb ft)
Transmission fill tube bolts	17 - 33 N·m (13 - 24 lb ft)
Transmission sight gauge bolts	2.7 - 5.5 N·m (2 - 4 lb ft)

Wheels

Wheel bolts	Initial torque: 298 N·m (220 lb ft) Final torque: 640 - 720 N·m (472 - 531 lb ft)
-------------	--

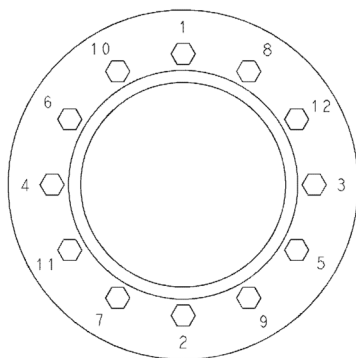

RCPH10WHL320AAH 1

Do the following initial and final torque procedures:

1. Tighten wheel bolts to an initial torque of **298 N·m (220 lb ft)** in sequence shown in figure
2. Tighten wheel bolts to a final torque of **640 - 720 N·m (472 - 531 lb ft)**, in sequence shown in figure

Capacities

621F WE, 621F NA, 721F WE, 721F NA

621F Capacities and Specifications

Engine	
Type of oil	CASE AKCELA ENGINE OIL 15W-40
Capacity (with filter change)	13.25 l (14.0 US qt)
Total system capacity	15.1 l (16 US qt)
Cooling System	
System capacity	26.8 l (28.4 US qt)
Hydraulic System	
Type of fluid	CASE AKCELA HY-TRAN® ULTRA™ HYDRAULIC TRANSMISSION OIL
Total system capacity	147.6 l (39.0 US gal)
Reservoir capacity	90.8 l (24.0 US gal)
Fuel System	
System capacity	246 l (65.0 US gal)
Transmission	
Type of oil	CASE AKCELA NEXPLORE™ FLUID
Service capacity (with filter change)	26.7 l (28.2 US qt)
Axles	
Type of oil	CASE AKCELA NEXPLORE™ FLUID
Standard front axle	22 l (23.2 US qt)
Standard rear axle	22 l (23.2 US qt)
Optional front axle	35 l (37.0 US qt)
Optional rear axle	35 l (37.0 US qt)
Diesel Exhaust Fluid (DEF)	
Total capacity	41.3 l (10.9 US gal)
Grease Fittings	
As required	CASE AKCELA MOLY GREASE

NOTE: Machines are shipped from the factory with break-in oil.

INTRODUCTION

721F Capacities and Specifications

Engine	
Type of oil	CASE AKCELA ENGINE OIL 15W-40
Capacity (with filter change)	13.25 l (14.0 US qt)
Total system capacity	15.1 l (16 US qt)
Cooling System	
System capacity	28.4 l (30.0 US qt)
Hydraulic System	
Type of fluid	CASE AKCELA HY-TRAN® ULTRA™ HYDRAULIC TRANSMISSION OIL
Total system capacity	177.8 l (47.0 US gal)
Reservoir capacity	90.8 l (24.0 US gal)
Fuel System	
System capacity	253 l (66.8 US gal)
Transmission	
Type of oil	CASE AKCELA NEXPLORE™ FLUID
Service capacity (with filter change)	34 l (35.9 US qt)
Axles	
Type of oil	CASE AKCELA NEXPLORE™ FLUID
Standard front axle	35 l (37.0 US qt)
Standard rear axle	23 l (24.3 US qt)
Optional front axle	35 l (37.0 US qt)
Optional rear axle	35 l (37.0 US qt)
Diesel Exhaust Fluid (DEF)	
Total capacity	41.3 l (10.9 US gal)
Grease Fittings	
As required	CASE AKCELA MOLY GREASE

NOTE: Machines are shipped from the factory with break-in oil.

Engine Oil Viscosity/Temperature Range

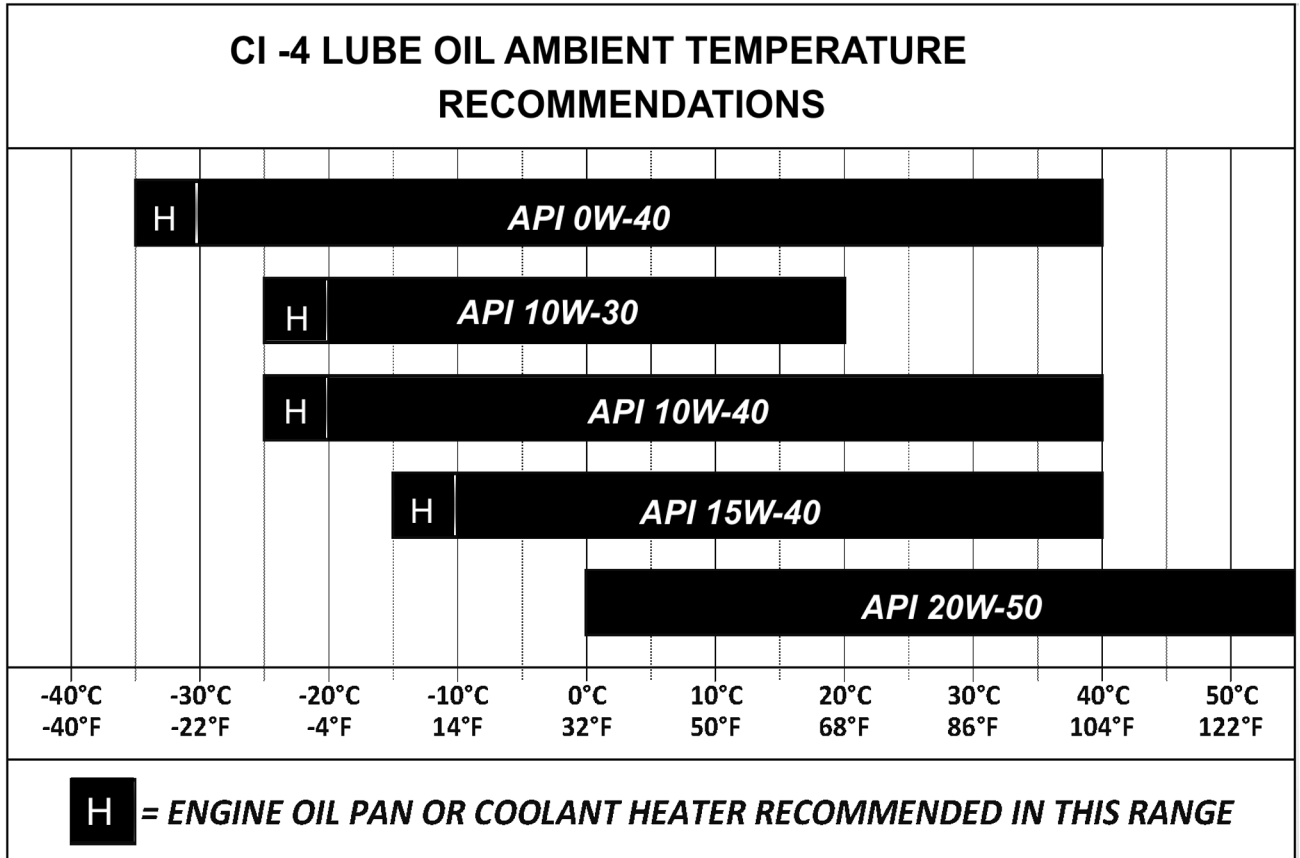

RCPH11WHL023FAH 1

NOTE: Use of an engine oil pan heater or an engine coolant heater may be required when operating temperatures are in Winter or Arctic conditions.

Transmission Oil Viscosity/Temperature Range

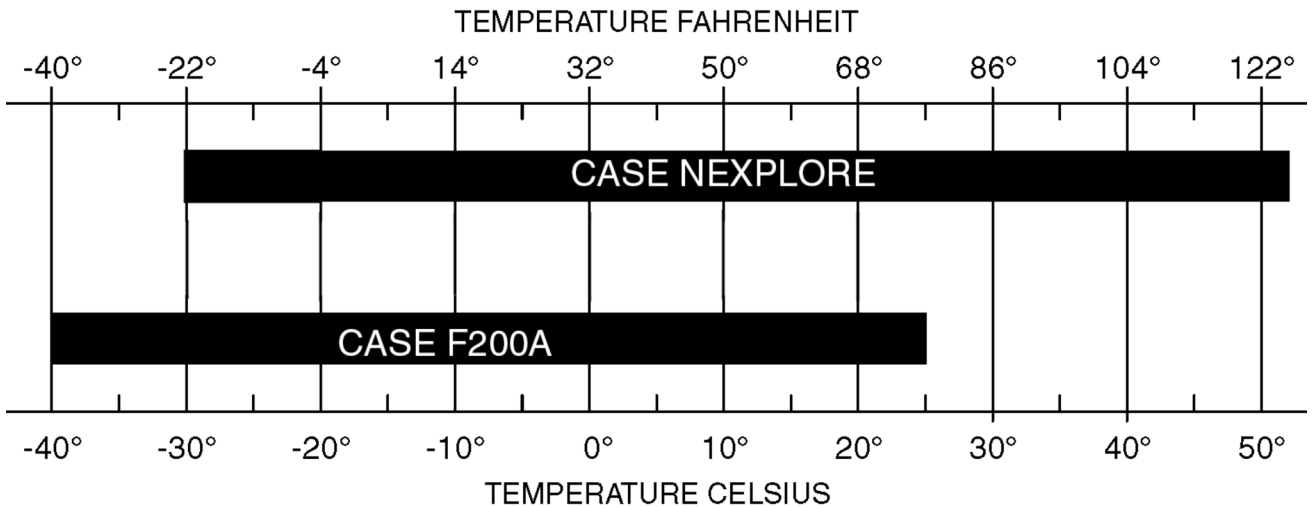

RCPH10WHL453BAH 2

Hydraulic/Brake System Temperature Range

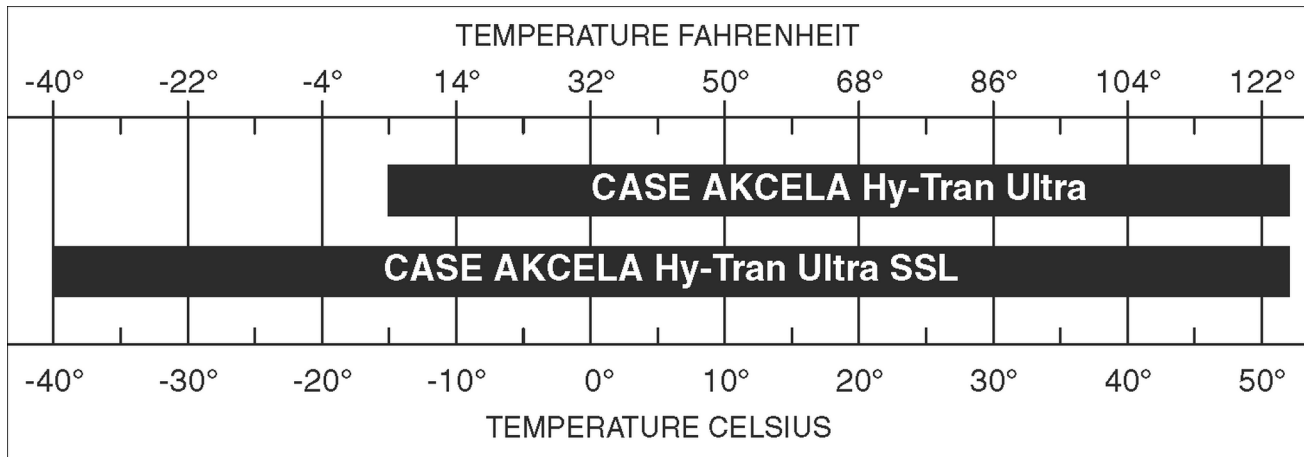

RCPH10WHL006EAL 3

Coolant Solution

Only use ethylene-glycol coolant solution in the cooling system. Use good quality ethylene-glycol that has a high boiling point with no additives to prevent leakage. Do not use non-approved anti-rust additives.

NOTICE: *Anti-rust additives and ethylene-glycol can mix and work against each other, reducing anti-corrosion protection, forming deposits in the cooling system, and causing damage to the cooling system and radiator. Contact your dealer who can supply you with the suitable coolant solution.*

Anti-freeze/Anti-corrosion

Use anti-freeze in all seasons to protect the cooling system from corrosion and risk of freezing. For areas where the ambient temperature is over **-36 °C (-32.8 °F)** use a blend of **50 %** ethylene-glycol based anti-freeze.

For areas where the temperature is below **-36 °C (-32.8 °F)**- it is advisable to use a blend of **40 %** water and **60 %** anti-freeze.

Fuel

- Use diesel fuel suitable for the ambient temperature conditions (ASTM-D-975).
- Use fuel which is to ASTM (American Society for Testing and Materials) D975 standard.
- Use grade No. 2 fuel. The use of other types of fuel can result in a loss of power of the engine and may cause high fuel consumption.
- For very low ambient temperatures, use a mixture of fuels No. 1 and No. 2 as necessary. Consult your fuel supplier for appropriate fuel supply.
- If the temperature falls below the fuel cloud point (point at which wax begins to form, the wax crystals will cause power loss or will prevent the engine from starting).
- In cold weather, fill the fuel tank at the end of the day's work in order to prevent the formation of condensation.

Fuel Storage

Prolonged storage of fuel can lead to the accumulation of impurities and condensation in the fuel. Engine trouble can often be traced to the presence of water in the fuel.

The storage tank must be placed outside and the temperature of the fuel should be kept as low as possible. Drain off water and impurities regularly.

Hydraulic Fluid

CASE AKCELA HY-TRAN® ULTRA™ HYDRAULIC TRANSMISSION OIL is specifically designed for high pressure applications and for Case hydraulic systems. Your Case Dealer can provide hydraulic fluid to fulfill different climate/temperature conditions. Refer to the charts at the beginning of this section.

Transmission Component Oil

Extreme pressure oil should be used for enclosed transmission components. Choose an oil that is manufactured for your climate/temperature conditions such as **CASE AKCELA NEXPLORE™ FLUID**. See charts at the beginning of this section.

Grease

The type of grease to use depends on ambient temperature such as: **CASE AKCELA MOLY GREASE**.

Environment

Before servicing machine and disposing oil, fluids, and lubricants, follow all environmental regulations. Do not drain oil or fluids on to the ground or into containers that leak. Check with your local environmental recycling center or your dealer for correct disposal information.

Engine Oil

CASE AKCELA ENGINE OIL 15W-40 is recommended for your engine. This oil insures correct lubrication of your engine in all working conditions. See charts at the beginning of this section to choose the correct oil for climate/temperatures.

If **CASE AKCELA ENGINE OIL 15W-40** cannot be obtained, use only oil of the API SERVICE CI-4 category.

NOTE: Do not put any Performance Additive or other additive in the sump. Oil change intervals shown in this manual are based on tests carried out utilizing Case lubricants.

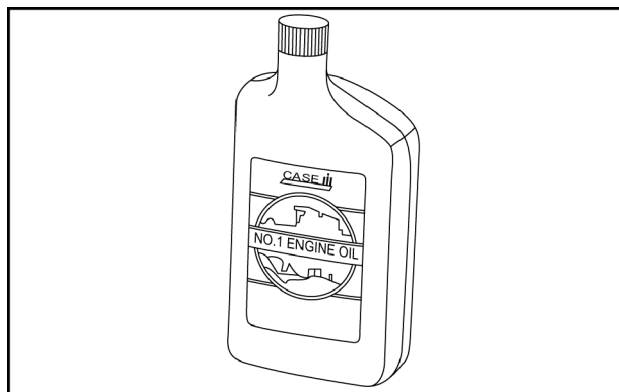

RCPH10WHL012AAD 4

Consumables - Biodiesel Fuel

Fatty Acid Methyl Ester Biodiesel (Biodiesel Fuel) consists of a family of fuels derived from vegetable oils treated with methyl esters.

NOTICE: *Biodiesel fuel blends are approved for your engine only if they comply with Specification Standards EN 14214 or ASTM D6751.*

NOTICE: *Verify with your local dealer which blends are approved for your engine. Use of biodiesel fuel that does not comply with the Standards EN14214 or ASTM D6751 could lead to severe damage to engine and fuel system. Use of non-approved biodiesel fuels may void warranty coverage.*

Biodiesel Fuel Usage Conditions

Biodiesel fuels must be purchased from a trusted supplier that understands the product and maintains good fuel quality. Biodiesel fuels must be pre-blended by the supplier. Mixing biodiesel fuels on site can result in an incorrect mixture which can damage engine and fuel system.

Engine performance is effected by the use of biodiesel fuels. There may be up to 12 percent reduction in power or torque depending on the blend used.

NOTICE: *DO NOT modify the engine and/or fuel injection pump settings to recover reduced performance.*

The reduced power must be accepted if using any biodiesel fuel blends.

NOTICE: *The use of high biodiesel fuel blends is not recommended in cold weather conditions.*

Using biodiesel fuels may require changing engine oil, engine oil filters, and fuel filter elements more frequently. Biodiesel fuels can remove rust and other particles that adhere to the inside of the fuel tank. These particles are trapped by vehicle filters and may cause shortened filter life or filter blockages. Blockages are more common in cold weather conditions. Consult your dealer for information on cold weather operation and proper maintenance intervals when using any biodiesel fuel blend.

Biodiesel fuel may degrade natural rubber gaskets and hoses, as it is more solvent than petro-diesel. Frequently inspect hoses and other engine components when using biodiesel fuel.

DO NOT allow water to collect in the fuel or storage tanks. Biodiesel fuel attracts moisture from the atmosphere. Keep fuel tanks and storage tanks as full as possible to limit the amount of air and water vapors. It may be necessary to drain machine fuel filter more frequently. Potential oxidation and stability could create a problem with fuel stored in the machine.

Biodiesel Storage

NOTICE: *DO NOT store machines for more than three months with biodiesel blends in the fuel system. DO NOT store biodiesel fuel in on-site storage tanks for more than three months.*

If long periods of storage are required, run the machine for 20 hours using regular diesel fuel to flush the biodiesel fuel from the engine fuel system.

NOTICE: *Biodiesel fuels must not be stored in on-site storage tanks for more than 3 months. Any spillage of biodiesel fuels must be cleaned up immediately before it can cause damage to the environment or the paint finish of the machine. Before using biodiesel fuel blends, you should consult with your dealer to receive full information about the approved blend for your machine and any detailed conditions of its usage. Failure to follow the requirements and conditions of biodiesel fuel usage will void your machine's warranty.*

NOTE: *B7 is the highest biodiesel (7% blend) that should be used in this machine.*

Hydraulic contamination

Contamination in the hydraulic system is a major cause of the malfunction of hydraulic components. Contamination is any foreign material in the hydraulic oil. Contamination can enter the hydraulic system in several ways.

- (A) When you drain the oil or disconnect any line.
- (B) When you disassemble a component.
- (C) From normal wear of the hydraulic components.
- (D) From damaged or worn seals.
- (E) From a damaged component in the hydraulic system.

All hydraulic systems operate with some contamination. The design of the components in this hydraulic system permits efficient operation with a small amount of contamination. An increase in this amount of contamination can cause problems in the hydraulic system. The following list includes some of these problems.

- (A) Cylinder rod seals leak.
- (B) Control valve spools do not return to neutral.
- (C) Movement of control valve spools is difficult.
- (D) Hydraulic oil becomes too hot.
- (E) Pump gears, housing, and other parts wear rapidly.
- (F) Relief valves or check valves held open by dirt.
- (G) Quick failure of components that have been repaired.
- (H) Cycle times are slow; machine does not have enough power.

If your machine has any of these problems, check the hydraulic oil for contamination. There are two types of contamination, microscopic and visible.

Microscopic contamination occurs when very fine particles of foreign material are in suspension in the hydraulic oil. These particles are too small to see or feel. Microscopic contamination can be found by identification of the following problems or by testing in a laboratory. Examples of the problems:

- (A) Cylinder rod seal leak.
- (B) Control valve spools do not return to NEUTRAL.
- (C) The hydraulic system has a high operating temperature.

Visible contamination is foreign material that can be found by sight, touch, or odor. Visible contamination can cause a sudden failure of components. Examples of visible contamination:

- (A) Particles of metal or dirt in the oil.
- (B) Air in the oil.
- (C) The oil is dark and thick.
- (D) The oil has an odor of burned oil.
- (E) Water in the oil.

If you find contamination, use a Portable Filter to clean the hydraulic system.

CONSUMABLES INDEX

Consumable	IU	PAGE
CASE Akcela Engine oil 15W-40	Capacities	7
CASE Akcela HY-TRAN® Ultra™ hydraulic transmission oil	Capacities	7
CASE Akcela NEXPLORE™ fluid	Capacities	7
CASE Akcela NEXPLORE™ fluid	Capacities	7
CASE Akcela Moly grease	Capacities	7
CASE Akcela Engine oil 15W-40	Capacities	8
CASE Akcela HY-TRAN® Ultra™ hydraulic transmission oil	Capacities	8
CASE Akcela NEXPLORE™ fluid	Capacities	8
CASE Akcela NEXPLORE™ fluid	Capacities	8
CASE Akcela Moly grease	Capacities	8
CASE Akcela HY-TRAN® Ultra™ hydraulic transmission oil	Capacities	11
CASE Akcela NEXPLORE™ fluid	Capacities	11
CASE Akcela Moly grease	Capacities	11
CASE Akcela Engine oil 15W-40	Capacities	11
CASE Akcela Engine oil 15W-40	Capacities	11

CASE

CONSTRUCTION

SERVICE MANUAL

Engine

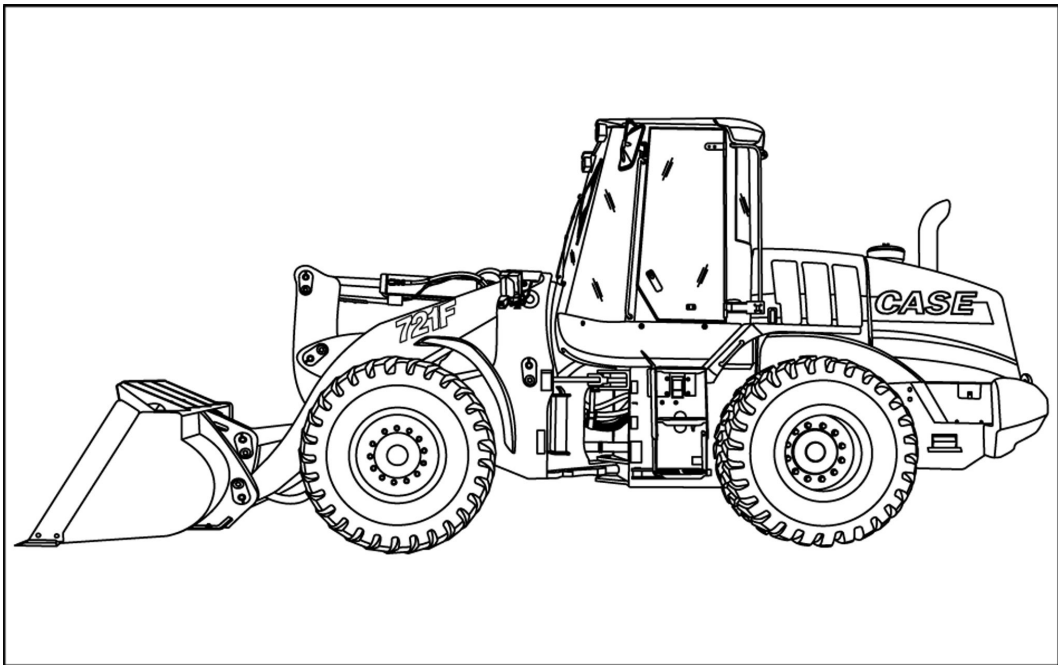

621F
721F

Contents

Engine - 10

Engine and crankcase	10.001
621F , 721F	
Air cleaners and lines	10.202
621F , 721F	
Engine lubrication system	10.304
621F , 721F	
Aftercooler	10.310
621F , 721F	
Engine cooling system	10.400
621F , 721F	
Fan and drive	10.414
621F , 721F	
Selective Catalytic Reduction (SCR) exhaust treatment	10.500
621F NA, 621F WE, 721F NA, 721F WE	
Engine generic sub-group	10.AAA
621F , 721F	