

**621F
721F
Tier 4
Wheel Loader**

OPERATOR'S MANUAL

Part number 84474094

2nd edition English

December 2011

Replaces part number 84376871



Contents

1 GENERAL INFORMATION

Note to the owner.....	1-1
Operator's manual storage	1-3
Right, left, front, and rear of the machine.....	1-4
Machine components.....	1-5
Note to the owner.....	1-7
Product identification	1-8
Electro-Magnetic Compatibility (EMC)	1-10

2 SAFETY INFORMATION

Safety rules and signal word definitions	2-1
Safety rules	2-2
Personal safety	2-3
Safety rules - Utility safety	2-4
Safety rules	2-5
Safety rules	2-6
Safety rules	2-7
Safety rules - Operating precautions	2-8
Safety rules - Maintenance precautions	2-10
Safety rules - Fuel handling	2-11
Safety rules - Burn prevention	2-12
Safety rules	2-13
Safety rules	2-14
Safety rules - Support strut and service link	2-15
Safety signs	2-17

3 CONTROLS/INSTRUMENTS

ACCESS TO OPERATOR'S PLATFORM

Proper entry and exit	3-1
-----------------------------	-----

OPERATOR'S SEAT

Overview	3-2
----------------	-----

FORWARD CONTROLS

Front console	3-7
Steering column	3-8
Pedal controls	3-10
Parking brake.....	3-12

LEFT-HAND SIDE CONTROLS

Transmission controls	3-13
Joystick steering.....	3-15

RIGHT-HAND SIDE CONTROLS

Overview	3-17
Two function valve.....	3-19
Three function valve	3-23
Four function valve	3-27
Wrist rest	3-29

EXTERIOR CONTROLS

Hood switch and master disconnect.....	3-30
--	------

INSTRUMENT CLUSTER

Overview	3-34
Status and warning icons.....	3-35
Display settings.....	3-43
Keypad	3-45
Operator preferences.....	3-53

SIDE CONSOLE

Overview	3-58
Switch operations.....	3-59
Climate controls	3-64

CLIMATE CONTROLS

Cab air louvers	3-66
Windows.....	3-68

4 OPERATING INSTRUCTIONS

COMMISSIONING THE UNIT

Before starting the engine	4-1
Run in period of a new machine.....	4-2

STARTING THE UNIT

Starting the engine	4-3
Operating in extreme temperatures	4-5
Cold temperature operation	4-6
Transport/service link.....	4-8

STOPPING THE UNIT

Stopping the engine	4-11
---------------------------	------

MOVING THE UNIT

Before operating the transmission.....	4-13
Ride control.....	4-14
Control levers.....	4-15
Auxiliary forward, neutral, reverse (F-N-R) switch.....	4-20
Automatic mode	4-24

Loader functions.....	4-25
-----------------------	------

5 TRANSPORT OPERATIONS

RECOVERY TRANSPORT

Safety rules.....	5-1
Transporting the machine.....	5-2
Moving a disabled machine.....	5-4

6 WORKING OPERATIONS

LOADER OPERATIONS

Operating tips.....	6-1
Changing loader attachments.....	6-4
Coupling to the attachment.....	6-6
Uncoupling the attachment.....	6-8
Joystick operation.....	6-12

7 MAINTENANCE

GENERAL INFORMATION

Servicing.....	7-1
Support strut for loader lift arm.....	7-3
Releasing pressure in the hydraulic system.....	7-5
Fluids and lubricants.....	7-7
Biodiesel fuel.....	7-12
Selective Catalytic Reduction (SCR) system.....	7-13

MAINTENANCE CHART

Maintenance Chart.....	7-16
------------------------	------

Daily inspection

General.....	7-18
--------------	------

Every 10 hours

Engine oil.....	7-22
-----------------	------

Every 50 hours

Bucket/attachment grease fittings.....	7-23
Grease machine and attachments.....	7-24
Hydraulic oil level.....	7-25
Transmission oil level.....	7-26
Engine coolant.....	7-27

Initial 100 hours

Wheel torque	7-28
Change engine oil and filter (Initial)	7-29
Replace hydraulic oil filters (Initial)	7-31
Clean in-line Diesel Exhaust Fluid (DEF) supply filter (Initial)	7-32
Fuel prefilter (Initial)	7-33
Fuel filter (Initial)	7-34

Every 100 hours

Grease fittings	7-35
Grease lift arm	7-37

Every 250 hours

Grease drive shaft slip joints	7-38
Cab air filter - Recirculation filter	7-39
Wheels and tires	7-41

Every 500 hours

Engine oil and filter	7-43
Replace fuel prefilter	7-45
Replace fuel filter	7-46
Fuel tank sediment	7-47
Axle oil level	7-48
Roll over protective structure	7-49
Battery fluid level	7-51

Every 1000 hours

Pivot points	7-52
Articulation fittings	7-53
Hydraulic oil filter	7-54
Drive belt	7-55
Cab air filter - Recirculation filter	7-57
Replacing the engine breather filter	7-59

Every 1500 hours

Change front and rear axle oil	7-60
Transmission fluid and filter	7-62
Clean breather	7-64
Selective catalytic reduction system - Replace supply module filter	7-65
Calibrating the gear box	7-66
Transmission declutch pressure adjustment 4-speed transmission only	7-68

Every 2000 hours

Hydraulic oil and filters	7-69
Engine coolant	7-71
Engine air filters	7-73

Frame and cab - lubricate	7-75
Engine valve clearance.....	7-75

Every 3000 hours

Selective catalytic reduction system - Replace supply module filter	7-76
---	------

As required

Fuel pre-filter	7-78
Selective catalytic reduction system - Clean tank filter.....	7-79
Air conditioning condenser	7-81
Height control and return to travel.....	7-82
Return to dig.....	7-84
Parking brake.....	7-88
Secondary steering.....	7-92
Cab service.....	7-93

ELECTRICAL SYSTEM

Battery service.....	7-96
Battery electrolyte level.....	7-99
Auxiliary battery connections.....	7-100
Battery removal and installation.....	7-102
Fuses and relays.....	7-103
Work lights.....	7-109
Driving lights.....	7-110
Rotating beacon light.....	7-111

STORAGE

Preparation for storage.....	7-112
Every 30 days.....	7-113
Removal.....	7-113

8 SPECIFICATIONS

General specifications.....	8-1
Lift capacities – 621F Lift Capacities.....	8-4
General specifications.....	8-8
Lift capacities - 721F Lift Capacities.....	8-12
Z-Bar dimensions 621F General Specifications.....	8-17
Z-Bar dimensions - 721F General Specifications.....	8-34
Weight adjustments.....	8-51
Material weights.....	8-53
Torque charts.....	8-54

9 ACCESSORIES

General accessories.....	9-1
--------------------------	-----

1 - GENERAL INFORMATION

Note to the owner

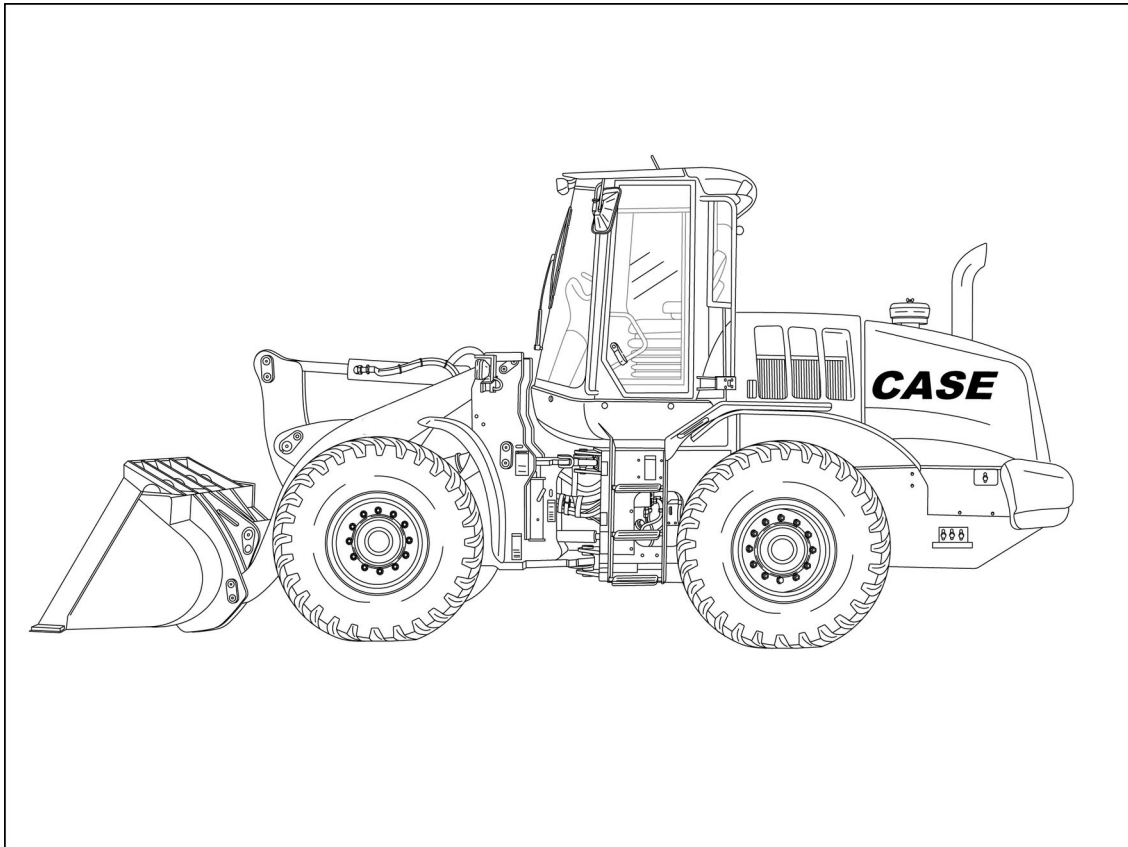

RCPH11WHL418FAH 1

Read this manual before you start the engine or operate the machine. If you need more information, see your Case dealer.

This manual contains important information about the safe operation, adjustment, and maintenance of your machine. Refer to the index at the back of this manual for locating specific items about your machine. The wheel loader conforms to current safety regulations.

Consult an authorized dealer or CNH America LLC on changes, additions, or modifications that can be required for this machine to comply with various country regulations and safety requirements. Unauthorized modifications will cause serious injury or death. Anyone making such unauthorized modifications is responsible for the consequences.

The information in this manual is provided on the basis of information that was available at the time the manual was written. Settings, procedures, part numbers, software and other items can change. These changes can affect the maintenance performed on the machine. Ensure that you have complete and current information from your dealer before you start any machine operation.

ATTENTION: *The fuel system and engine on your machine are designed and built to government emissions standards. Tampering by dealers, customers, operators, and users is strictly prohibited by law. Failure to comply could result in government fines, rework charges, invalid warranty, legal action, and possible confiscation of the machine until rework to original condition is completed. Engine service and/or repairs must be done by a certified technician only!*

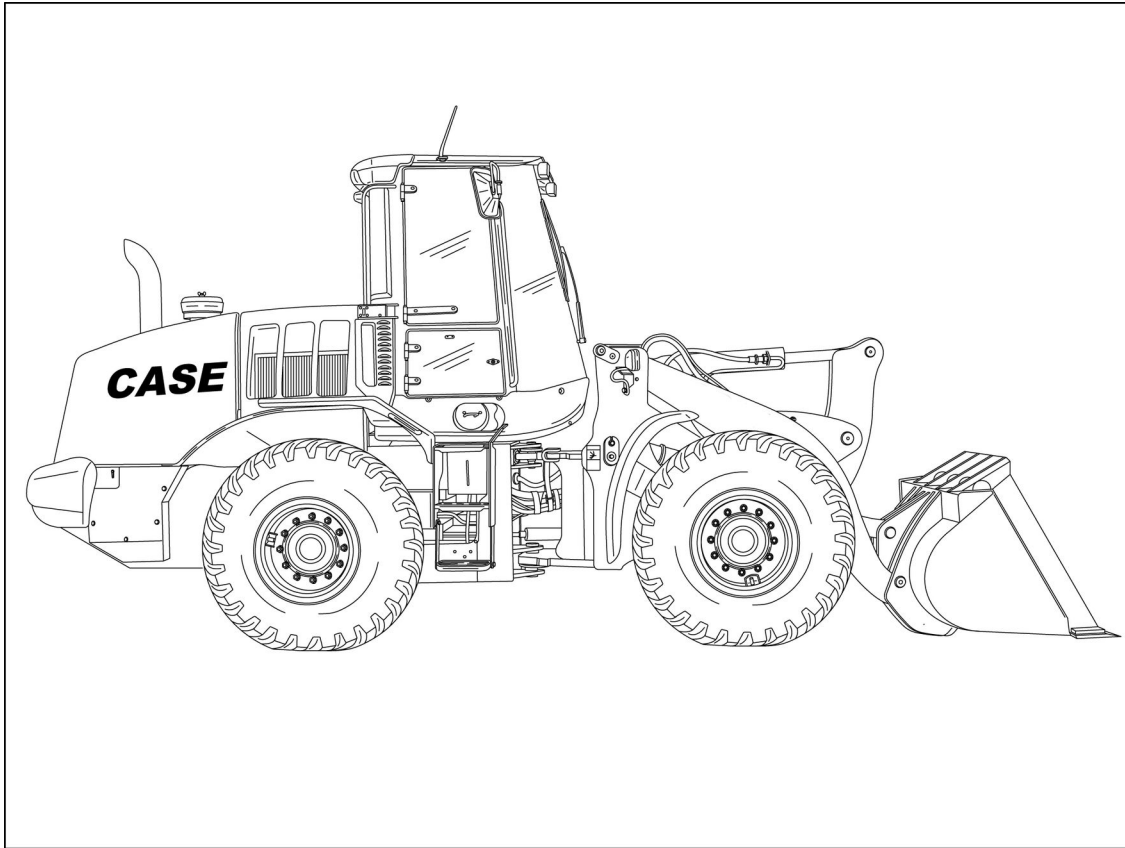

RCPH11WHL416FAH 2

DO NOT OPERATE or permit anyone to operate or service this machine until you or the other persons have read and understand the safety, operation and maintenance instructions in this manual. Use only trained operators who have demonstrated the ability to operate and service this machine correctly and safely.

This Wheel Loader, with standard equipment and attachments is intended to be used for digging and general earth moving purposes such as land leveling, truck loading, and material rehandling. This machine is not intended to be used for lifting other objects or transporting loads at high speeds.

DO NOT use this machine for any application or purpose other than those described in this manual, decals, or other product safety information provided with the machine. These materials define the machine's intended use.

If the loader is to be used in an application that involves special attachments or equipment, such as forestry, etc., consult an authorized dealer. Consult an authorized dealer on changes, additions or modifications that can be required for this machine to comply with various country regulations and safety requirements. Unauthorized modifications may cause serious injury or death. Anyone making such unauthorized modifications is responsible for the consequences.

Before permitting a new operator on this machine, make certain:

- That the operator has received the necessary training to operate the machine correctly and safely.
- That the operator has read and understands the instructions given in this manual.

All persons who will be operating this machine shall possess a valid local vehicle operating permit and/or other applicable local age work permits.

This Operators Manual is to be stored in the manual compartment equipped on this machine. Make sure this manual is complete and in good condition. Contact your dealer to obtain additional manuals or manuals in languages other than that of the country of use.

Your dealer is at your disposal for any further information, and can provide any after-sales service you may require, as well as genuine Case replacement parts, your guarantee of quality and match.

Case Customer Assistance can be reached at:
1-866-54-CASE6 (1-866-542-2736 or e-mail: casecustomerassistance.na@cnh.com).

Operator's manual storage

To access the operator manual storage area located on the back of the operator's seat, release the latch on top of the seat and open the compartment.

READ THIS MANUAL COMPLETELY and make certain you understand the controls. All equipment has a limit. Make sure you understand the speed, brakes, steering, stability and load characteristics of this machine before you start to operate.

DO NOT remove this manual or the safety manual from the machine. See your dealer for additional manuals. Keep the Operator's Manual and the safety video in the storage compartment provided on the machine. The Operator's Manual and safety video must be available for use by all operators.

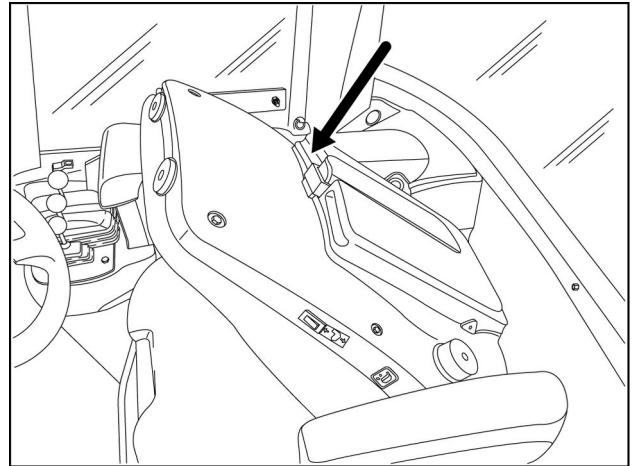

RCPH11WHL0030AA 1



When you see this symbol read your operator's manual.



When you see this symbol refer to your repair manual.

Right, left, front, and rear of the machine

The terms right-hand, left-hand, front, and rear are used in this manual to indicate the sides as they are seen from the operator's seat.

1. Front
2. Right
3. Rear
4. Left

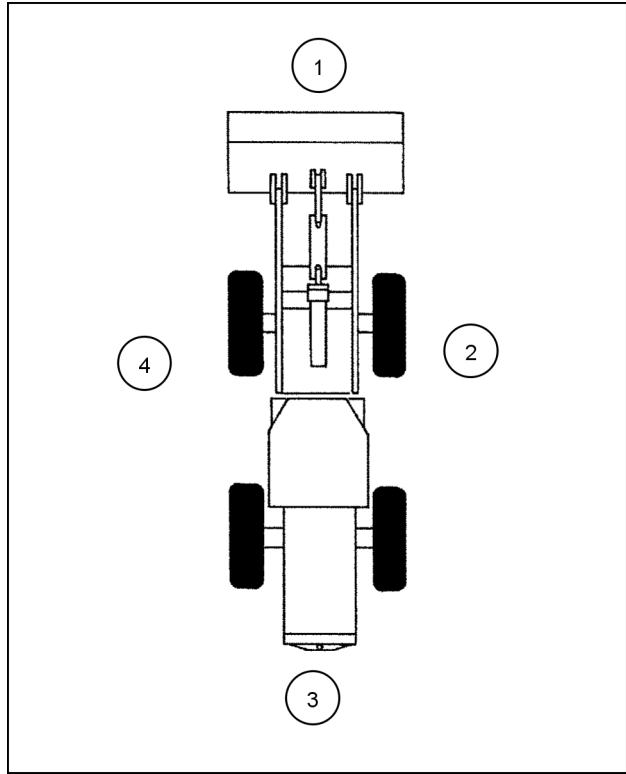

RCPH10WHL003BAH 1

Machine components

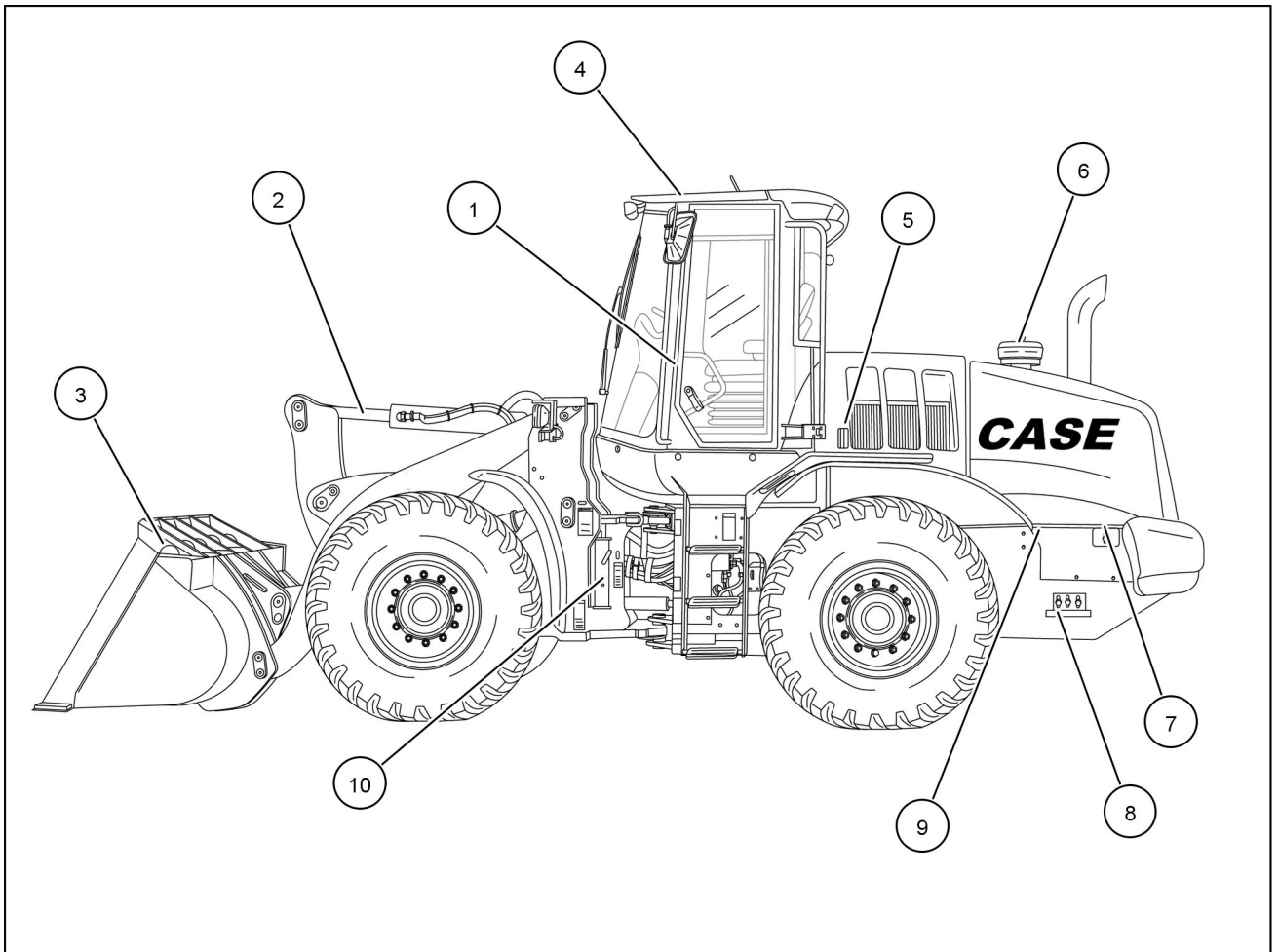

RCPH11WHL418FAH 1

- | | |
|--|---|
| 1. Cab door and hand holds | 6. Precleaner |
| 2. Bucket cylinder | 7. Electric disconnect and optional battery jump post |
| 3. Bucket | 8. Remote drain |
| 4. Roll Over Protection Structure (ROPS) cab | 9. Battery access |
| 5. Hydraulic fluid sight gauge | 10. Lift arm support strut |

1 - GENERAL INFORMATION

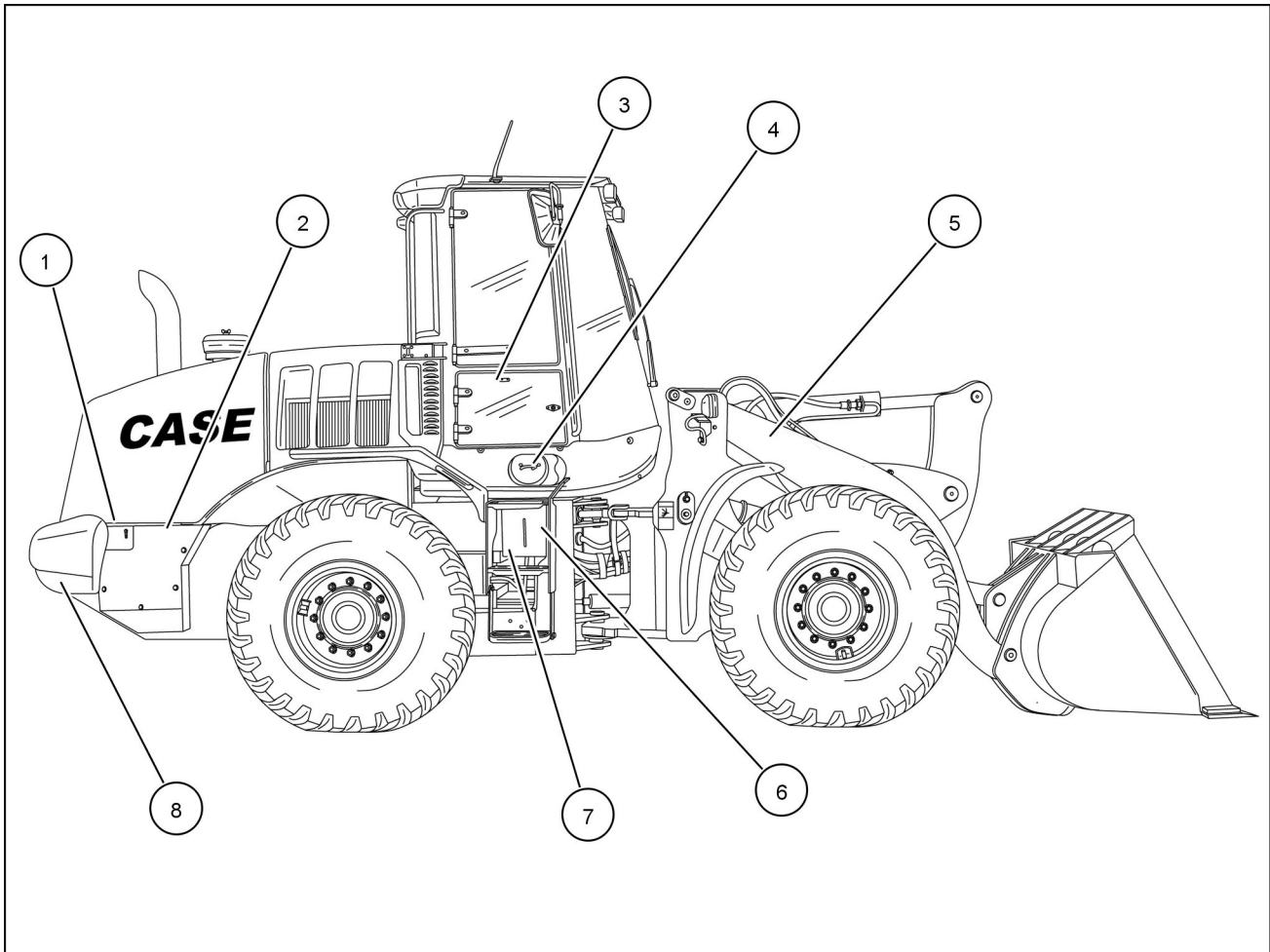

RCPH11WHL416FAH 2

- | | |
|---|---|
| 1. Diesel Exhaust Fluid (DEF) fill tank | 5. Lift arm |
| 2. Right battery access | 6. Windshield washer reservoir |
| 3. Fuse access door | 7. Transmission and hydraulic filter(s) |
| 4. Cab air filter access | 8. Counterweight |

Note to the owner

This manual contains information concerning the adjustment and maintenance of your new equipment. You have purchased a dependable machine, but only by proper care and operation can you expect to receive the performance and long service built into this equipment. Please have all operators read this manual carefully and keep it available for ready reference.

Your authorized dealer will instruct you in the general operation of your new equipment. Your dealer's staff of factory-trained service technicians will be glad to answer any questions that may arise regarding the operation of your machine.

Your authorized dealer carries a complete line of genuine service parts. These parts are manufactured and carefully inspected to insure high quality and accurate fitting of any necessary replacement parts. Be prepared to give your dealer the model and product identification number of your new equipment when ordering parts. Locate these numbers now and record them below. Refer to the 'General Information' section of this manual for the location of the model and product identification numbers of your machine.

PLEASE RECORD THE FOLLOWING INFORMATION

Model _____

Date Purchased _____

	<p>This is the safety alert symbol. It is used with and without signal words to alert you to potential personal injury hazards. Obey all safety messages that follow this symbol to avoid possible death or injury.</p>
--	---

⚠ WARNING

Illustrations in this manual may show protective shielding open or removed to better illustrate a particular feature or adjustment.

Replace all shields before operating the machine.

Failure to comply could result in death or serious injury.

W0012A

IMPROVEMENTS

CNH America LLC is continually striving to improve its products. We reserve the right to make improvements or changes when it becomes practical and possible to do so, without incurring any obligation to make changes or additions to the equipment sold previously.

Product identification

Model, serial number, and year of manufacture

Record the machine and part identification numbers. When ordering parts, obtaining information or assistance, always supply your dealer with the type and serial number of your machine or accessories. Keep a record of these numbers and your Manufacturer's Statement of Origin in a safe place. If the machine is stolen, report the numbers to your local law enforcement agency.

Machine identification

Model name

PIN

Model year

The Product Identification Number (PIN) plate is located on the left-hand side of the machine.

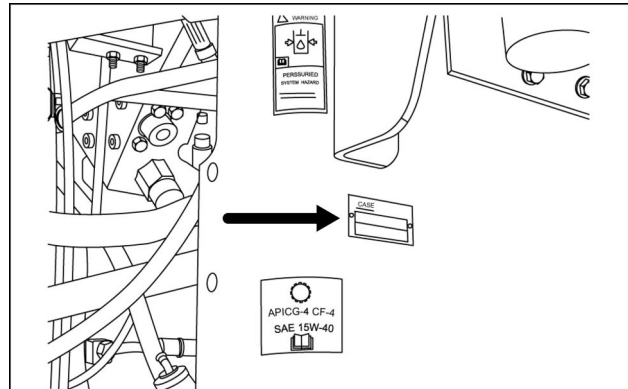

RCIL10WHL014AAL 1

Roll-Over Protective Structure (ROPS)

The serial number plate is behind the operator's seat on the air filter cover.

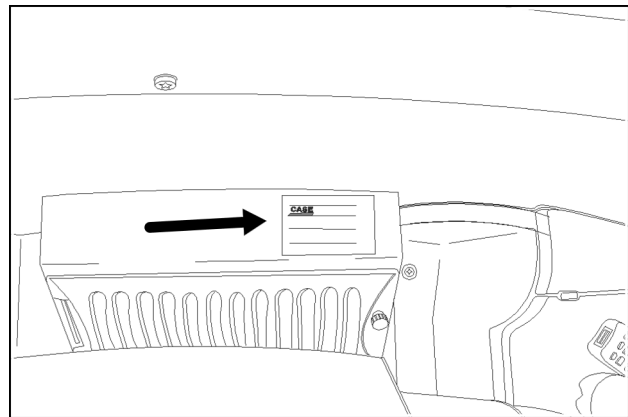

RCIL10WHL013AAL 2

Engine make and model

Engine serial number

The serial number plate is on the engine block.

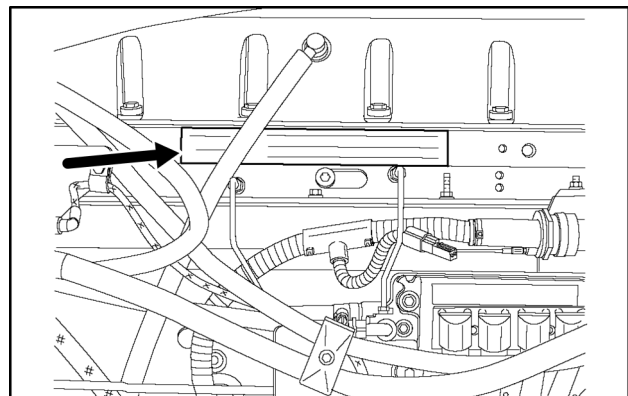

RCIL10WHL015AAL 3

Transmission

The serial number plate is on the transmission face plate.

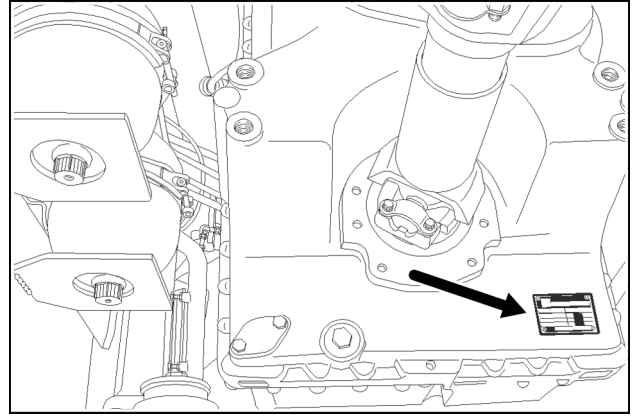

RCPH10WHL004BAH 4

Axle

The serial number plate is on the axle cross member.

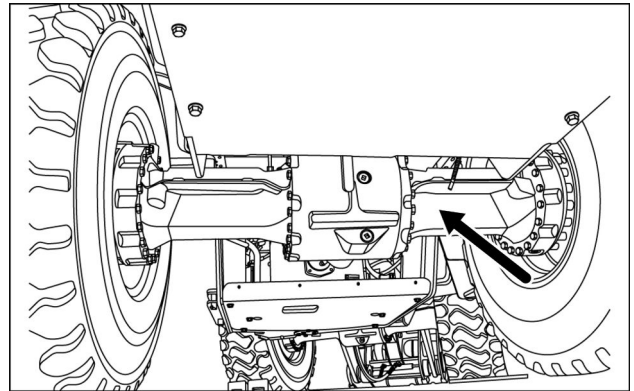

RCPH10WHL081AAH 5

Electro-Magnetic Compatibility (EMC)

Interference may arise as a result of add on equipment which may not necessarily meet the required standards. As such interference can result in serious malfunction of the unit and/or create unsafe situations, you must observe the following:

- The maximum power of emission equipment (radio, telephones, etc.) must not exceed the limits imposed by the national authorities of the country where you use the machine.
- The electromagnetic field generated by the add on system should not exceed **24 V/m** at any time and at any location in the proximity of electronic components.
- The add on equipment must not interfere with the functioning of the on board electronics.

Failure to comply with these rules will render the warranty null and void.

2 - SAFETY INFORMATION

Safety rules and signal word definitions

Personal safety



This is the safety alert symbol. It is used to alert you to potential personal injury hazards. Obey all safety messages that follow this symbol to avoid possible death or injury.

Throughout this manual and on machine decals, you will find the signal words DANGER, WARNING, and CAUTION followed by special instructions. These precautions are intended for the personal safety of you and those working with you.

Read and understand all the safety messages in this manual before you operate or service the machine.

! DANGER indicates a hazardous situation which, if not avoided, will result in death or serious injury. The color associated with DANGER is RED.

! WARNING indicates a hazardous situation which, if not avoided, could result in death or serious injury. The color associated with WARNING is ORANGE.

! CAUTION, used with the safety alert symbol, indicates a hazardous situation which, if not avoided, could result in minor or moderate injury. The color associated with CAUTION is YELLOW.

FAILURE TO FOLLOW DANGER, WARNING, AND CAUTION MESSAGES COULD RESULT IN DEATH OR SERIOUS INJURY.

Machine safety

NOTICE: Notice indicates a situation which, if not avoided, could result in machine or property damage. The color associated with Notice is BLUE.

Throughout this manual you will find the signal word Notice followed by special instructions to prevent machine or property damage. The word Notice is used to address practices not related to personal safety.

Information

NOTE: Note indicates additional information which clarifies steps, procedures, or other information in this manual.

Throughout this manual you will find the word Note followed by additional information about a step, procedure, or other information in the manual. The word Note is not intended to address personal safety or property damage.

Safety rules

CALIFORNIA

Proposition 65 Warning

Diesel engine exhaust and some of its constituents are known to the State of California to cause cancer, birth defects, and other reproductive harm.

Battery posts, terminals and related accessories contain lead and lead compounds. Wash hands after handling.

RCIL08CCH001EAA 1

Personal safety

Most accidents involving machine operation and maintenance can be avoided by following basic safety rules and precautions. Read and understand all the safety messages in this manual, the safety manual and the safety signs on the machine before you operate or service the machine. See your dealer if you have any questions.

READ THIS MANUAL COMPLETELY and make sure you understand the controls. All equipment has a limit. Make sure you understand the speed, brakes, steering, stability, and load characteristics of the machine before you start to operate this machine.

DO NOT remove this manual or the safety manual from the machine. See your dealer for additional manuals. Also see the manual information on the Title pages (first and second pages in front of the Table of Contents) of this manual.

The safety information given in this manual does not replace safety codes, insurance needs, federal, state, or local laws. Make sure that your machine has the correct equipment according to these rules or laws.

Additional safety messages are used in the text of the manual to show specific safety hazards.

NOTICE: *The safety messages in this chapter point out conditions which can happen during the normal operation and maintenance of your machine. These safety messages also give possible ways of dealing with these conditions.*

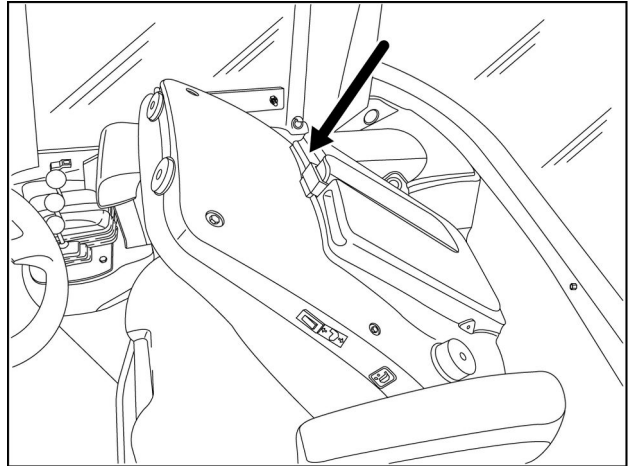

RCPH11WHL0030AA 1

Safety rules - Utility safety

⚠ WARNING

Electrical shock hazard!

Do not work under overhangs or electric wires. Do not work where there is a danger of sliding. Failure to comply could result in death or serious injury.

W0215A

Safety precautions must be followed when working near buried and overhead utility lines.

During operation it is likely that you will be working around or near buried or overhead utility lines which may include, but are not limited to:

- Electrical power line
- Gas line
- Water line
- Communication line - telephone or cable television
- Sewer line

NOTICE: Before beginning any machine operation, it is your responsibility to be aware of all such utility lines buried and overhead in the area of your project and to avoid them.

Always have all local utility companies mark the location of their lines.

In U.S.A. and Canada, call one of many “One Call System Directory” services. If you do not know the local number, call the national number (U.S.A. and Canada only): 1-888-258-0808.

NOTICE: Check with local authorities for laws, regulations and/or strict penalties requiring you to locate and avoid existing utilities.

Call all local utility companies before you perform any machine operation

Know the utility color code (U.S.A. and Canada):	
Electric	Red
Gas, oil, or petroleum	Yellow
Communication, telephone, television	Orange
Water	Blue
Sewer	Green/Brown
Proposed excavation	White
Surveying	Pink
Reclaimed water and slurry	Purple

After locating any buried utility lines, carefully dig a hole by hand and/or automatic vacuum equipment to the utility line to verify the location and depth of the line.

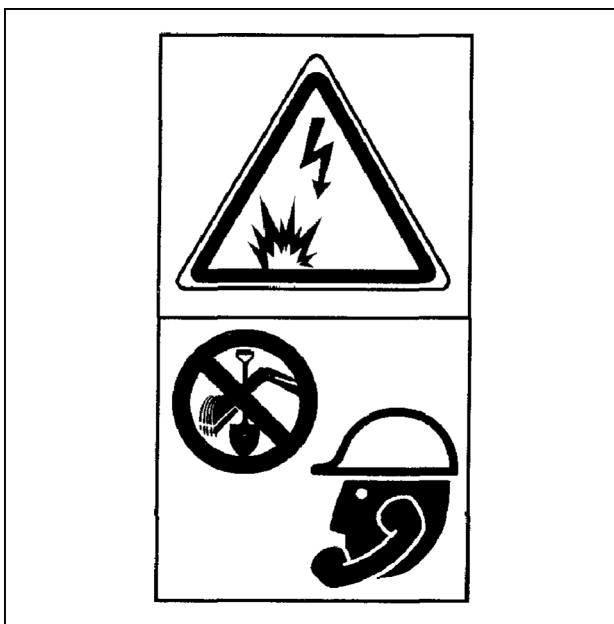

RCPH10WHL001BAH 1