

## W14, W14H, AND W14FL LOADERS, PIN 9119672 AND AFTER

### TABLE OF CONTENTS

DIVISION/SECTION	SECTION NO.	FORM NO.
<b>1 GENERAL</b>		
Safety Rules, Service Manual Introduction, Location of Serial Numbers and Product Identification Number (PIN), and Torque Specifications .....	1001	8-41980
Maintenance and Lubrication Charts .....	1002	8-41980
General Engine Specifications .....	1010	8-24320
Detailed Engine Specifications .....	1023	9-78647
<b>2 ENGINES</b>		
Engine Stall Tests, Engine Removal and Installation, Engine Accessories .....	2000	8-41980
Engine Diagnosis - See Section 2201		
Engine Tune-Up .....	2002	8-23140
Cylinder Head, Valve Train, and Camshaft .....	2015	8-23150
Cylinder Block, Sleeves, Pistons, and Rods .....	2025	8-23160
Crankshaft, Main Bearings, Flywheel, and Oil Seals .....	2035	8-23170
Lubrication System .....	2047	8-23180
Cooling System .....	2055	8-23190
Engine Diagnosis .....	2201	8-20111
Reconditioning Engine Cylinder Block .....	2290	8-21170
Turbocharger Failure Analysis .....	2565	9-78235
<b>3 FUEL SYSTEM</b>		
Fuel Lines, Fuel Tank, and Engine Controls .....	3001	8-41980
Electric Fuel Pump .....	3002	8-41980
Fuel System and Filters .....	3010	9-75297
Robert Bosch Fuel Injection Pumps .....	3012	9-74937
17 mm Fuel Injectors .....	3213	8-20240
<b>4 ELECTRICAL</b>		
Electrical System Troubleshooting .....	4002	8-41980
Wiring Diagrams .....	4003	8-41980
Instrument Cluster, Gauges, and Warning Lamps .....	4004	8-41430
Batteries .....	4005	8-41430
Starter .....	4006	8-41980
Alternator .....	4007	8-41980
<b>5 STEERING</b>		
Steering System Troubleshooting .....	5002	8-41980
Steering Control Valve and Steering Column .....	5007	9-41980
Steering Cylinders .....	5010	8-41980
Center Pivot .....	5023	8-41980
Auxiliary Steering .....	5025	8-41980
<b>6 POWER TRAIN</b>		
Transmission Maintenance, Troubleshooting, and Pressure Checks ...	6102	8-41980
Transmission Operation .....	6103	8-41430
Transmission Removal, Installation, Disassembly, and Assembly .....	6110	8-41980
Transmission Controls .....	6118	8-41980
Drive Shaft, Center Bearing, and Universal Joints .....	6120	8-41980
Rear Axle Trunnion .....	6125	8-41980
Axle and Planetaries .....	6126	8-41980
Wheels and Tires .....	6129	8-41980

DIVISION/SECTION	SECTION NO.	FORM NO.
7	<b>BRAKES</b>	
	Air System Description, Diagram, and Troubleshooting .....	7102 8-41980
	Air Compressor, Governor, and Reservoir .....	7103 8-41980
	Brake Valve .....	7105 8-41980
	Brake Actuator.....	7107 8-41980
	Pressure Reducing Valve and Pressure Protection Valve .....	7109 8-41980
	Air Horn and Air Horn Valve .....	7110 8-41430
	Alcohol Evaporator.....	7111 8-41980
	Double Check Valve and Stop Lamp Switch .....	7112 8-41980
	Brakes .....	7121 8-41980
	Disc Brake.....	7122 8-41980
	Parking Brake System.....	7126 8-41980
8	<b>HYDRAULICS</b>	
	Hydraulic System Specifications, Diagrams, Maintenance, Troubleshooting, and Pressure Checks .....	8002 8-41980
	Cleaning the Hydraulic System.....	8003 8-41980
	Hydraulic Pump.....	8005 8-41980
	Loader Control Valve.....	8007 8-41980
	Hydraulic Cylinders .....	8090 8-41980
	Backhoe Relief Valves and Selector Valve .....	8106 8-41980
	Backhoe Control Valve.....	8107 8-41980
	Stabilizer Control Valve for 35 Backhoe .....	8109 8-41980
9	<b>MOUNTED EQUIPMENT</b>	
	Air Conditioning Troubleshooting .....	9002 8-41430
	Air Conditioning System.....	9003 8-41430
	Loader .....	9010 8-41980
	Cab and Canopy.....	9061 8-41430
	Operators Seat and Seat Belt.....	9064 8-41430
	Backhoe Model 26.....	9100 8-41980
	Backhoe Model 35.....	9101 8-41980
	Decals, Painting, and Noise Control.....	9201 8-41980

# Section 1001

## SAFETY RULES SERVICE MANUAL INTRODUCTION AND TORQUE SPECIFICATIONS

Written In *Clear  
And  
Simple  
English*

## SAFETY RULES



**This Symbol Shows Important Information About Safety In This Manual. When You See This Symbol, Carefully Read The Information That Follows and Understand The Possible Causes of Injury Or Death.** 1-1-A

**NOTE:** *To prevent injury on job, follow the Warning, Caution, and Danger notes in this section and other sections throughout this manual. Follow the instructions carefully.*

The procedures recommended and shown in this manual are good, effective service methods. However, all possible procedures and service hazards may not be covered. Therefore, if you use a tool or procedure not recommended, you must make sure that the method you select is a safe method.

Put the warning tag shown below on the key for the key switch when you are servicing or repairing this machine. One warning tag is on every new machine. You can buy additional warning tags, part number 331-4614, from Service Parts Supply.





**WARNING:** *This is a one man machine, no riders allowed.* 35-8



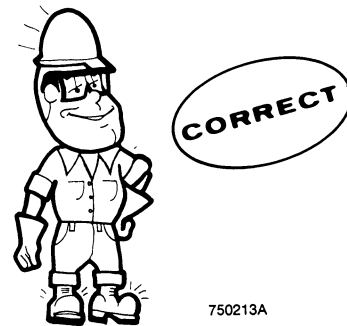

**WARNING:** *If you wear clothing that is too loose or do not use the correct safety equipment for your job, you can be injured. Always wear clothing that will not catch on objects. Extra safety equipment that can be required includes hard hat, safety shoes, ear protection, eye or face protection, heavy gloves and reflector clothing.* 45-3-A





**WARNING:** *Read operator's manual to familiarize yourself with control lever functions.* 46-27

**WARNING:** *Operate tractor and equipment controls from the seat position only. Any other method could result in serious injury.* 48-55

**WARNING:** *When working in the area of the fan belt with the engine running, avoid loose clothing if possible, and use extreme caution.* 35-4

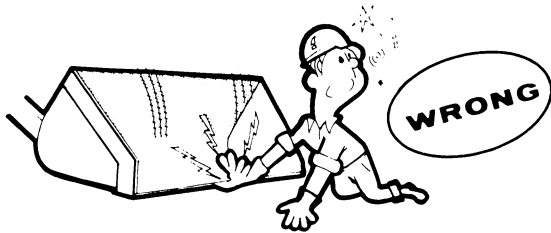
**WARNING:** Whenever the bucket must be raised to aid in servicing, block the loader arms in place with lift cylinder support strut or a suitable safety stand. 23-7-B



**WARNING:** When doing checks and tests on the equipment hydraulics, follow the procedures as they are written. DO NOT change the procedure. 47-44

**WARNING:** When putting the hydraulic cylinders on this machine through the necessary cycles to check operation or to remove air from a circuit, make sure all people are out of the way. 47-45

**WARNING:** Locate the machine on level ground and block the wheels securely before working under the machine. Failure to follow the above procedure can result in personal injury. 46-77



750147

**CAUTION:** Pin sized and smaller streams of hydraulic oil under pressure can penetrate the skin and result in serious infection. If hydraulic oil under pressure does penetrate the skin, seek medical treatment immediately. Maintain all hoses and tubes in good condition. Make sure all connections are tight. Make a replacement of any tube or hose that is damaged or thought to be damaged. DO NOT use your hand to check for leaks; use a piece of cardboard or wood. 40-6-A

**WARNING:** Use insulated gloves or mittens when working with hot parts. 47-41A

**CAUTION:** When removing hardened pins such as a pivot pin, or a hardened shaft, use a soft head (brass or bronze) hammer or use a driver made from brass or bronze and a steel head hammer. 46-17

**CAUTION:** When using a hammer to remove and install pivot pins or separate parts, using compressed air or using a grinder, wear eye protection that completely encloses the eyes (approved goggles or other approved eye protectors). 46-13

**CAUTION:** When servicing or repairing the machine, keep the shop floor and operator's compartment and steps free of oil, water, grease, tools, etc. Use an oil absorbing material and/or shop cloths as required. Use safe practices at all times. 40-8

**CAUTION:** Use suitable floor (service) jacks or chain hoists to raise wheels or track off the floor. Always block machine in place with suitable safety stands. 40-7-A

**CAUTION:** Some components of this machine are very heavy. Use suitable lifting equipment or additional help as instructed in this service manual. 40-10

**DANGER:** Engine exhaust fumes can cause death. If it is necessary to start the engine in a closed place, remove the exhaust fumes from the area with an exhaust pipe extension. If you do not have an exhaust pipe extension, open the doors and get outside air into the area. 48-56



750149

## SERVICE MANUAL INTRODUCTION

This service manual has been prepared with the latest service information available. Troubleshooting, removal, disassembly, inspection and installation procedures, and complete specifications and tightening references can be found in most sections. Some sections have drawings but no written procedure because the job is so easily done. This service manual is one of the most important tools available to the service technician.

### Right, Left, Front, and Rear

The terms right-hand and left-hand and front and rear as used in this manual indicate the right and left sides, and front and rear of the machine as seen from the operator's seat for correct operation of the machine or attachment.

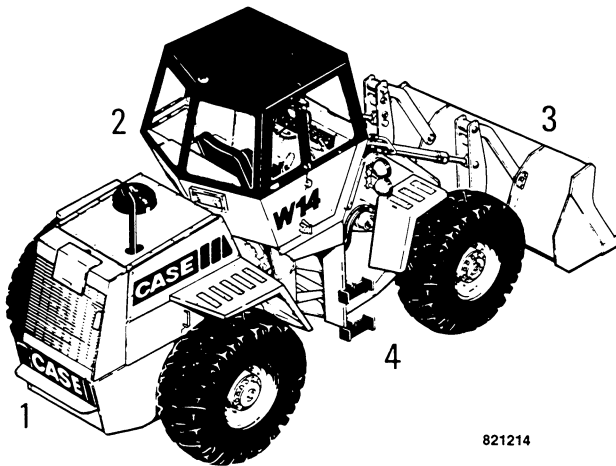

1. Rear                      3. Front  
2. Left Side                4. Right Side

821214

### Text

If the service manual is for more than one machine or different models of components (planetary axles, gear boxes, control valves, etc.) the procedures have the steps necessary to service each model.

### Table of Contents

A Table of Contents is in the front of this manual. The Table of Contents shows the main divisions and the sections that are in each division. The individual sections, where necessary, have a Table of Contents on the second page of that section.

### Page Numbers

All page numbers are made of two numbers separated by a dash, such as 4002-9. The number before the dash is the section number. The number following the dash is the page number in that section. Page numbers will be found at the upper right or left of each page.

### Illustrations

Illustrations are put as near as possible to the text and are to be used as part of the text.

### Classification of Lubricants

The SAE number is the viscosity of engine oils. For example, SAE 30 is a single viscosity oil. SAE 10W30 is a variable viscosity oil.

The API classification (SD, CD, etc.) is the oil performance in terms of engine usage. Only oils specified in Section 1002 can be used. These oils have the needed chemical additives to give maximum engine protection. Both the SAE grade and API classification must be found on the container.

### Gear Lubricant and Grease

Gear lubricant and grease for each application is specified in Section 1002.

### Special Tools

Special tools are needed to remove and install, disassemble and assemble, check and adjust some component parts of this machine. Some special tools can be easily made locally and the necessary information to make the tool is in this service manual. Other special tools are more difficult to make locally and are available from Service Tools in the U.S. and from Jobborn Manufacturing in Canada. Use these tools according to the instructions in this service manual for your personal safety and to do the job correctly.

Order special tools from either of the following companies

Service Tools  
P.O. Box 314  
Owatonna, Minnesota 55060

Jobborn Manufacturing Co.  
97 Frid Street  
Hamilton, Ontario L8P 4M3  
Canada

## Product Identification Number (PIN) and Serial Numbers

**NOTE:** A serial number plate is also on many components such as the starter, alternator, pumps, etc.

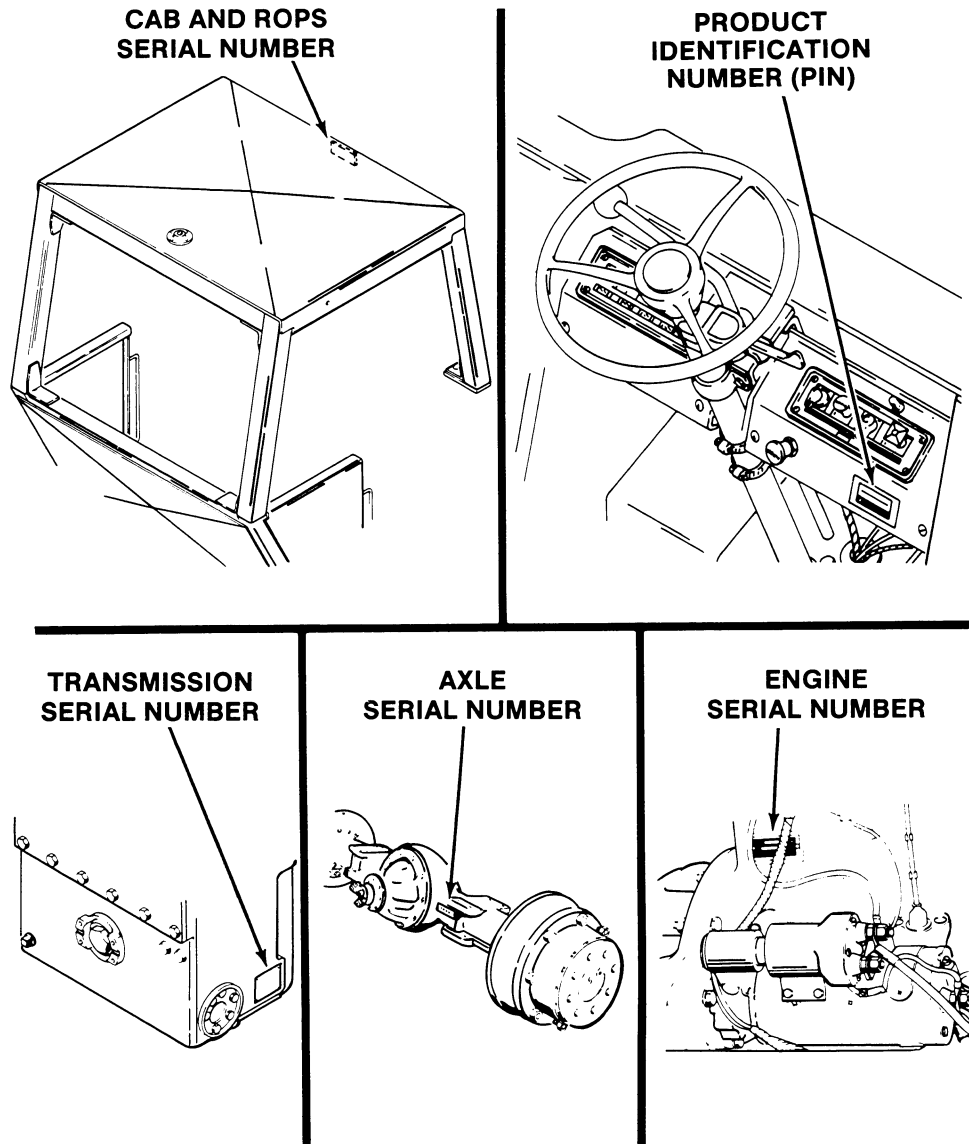

## TORQUE SPECIFICATIONS - U.S. HARDWARE

Use the torques in this chart when special torques are not given. These torques apply to fasteners with both UNC and UNF threads as received from suppliers, dry, or when lubricated with engine oil. Not applicable if special graphites, moly-disulfide greases, or other extreme pressure lubricants are used.

<b>Grade 5 Bolts, Nuts, and Studs</b>			
			
Size	Pound-Feet	Newton metres	Kilogram metres
<b>1/4 in</b> 6.4 mm	9-11	12-15	1.2-1.5
<b>5/16 in</b> 7.9 mm	17-21	23-28	2.4-2.9
<b>3/8 in</b> 9.5 mm	35-42	48-57	4.8-5.8
<b>7/16 in</b> 11.1 mm	54-64	73-87	7.5-8.8
<b>1/2 in</b> 12.7 mm	80-96	109-130	11.1-13.3
<b>9/16 in</b> 14.3 mm	110-132	149-179	15.2-18.2
<b>5/8 in</b> 15.9 mm	150-180	203-244	20.8-24.9
<b>3/4 in</b> 19.0 mm	270-324	366-439	37.3-44.8
<b>7/8 in</b> 22.2 mm	400-480	542-651	55.3-66.4
<b>1.0 in</b> 25.4 mm	580-696	787-944	80.2-96.2
<b>1-1/8 in</b> 28.6 mm	800-880	1085-1193	111-122
<b>1-1/4 in</b> 31.8 mm	1120-1240	1519-1681	155-171
<b>1-3/8 in</b> 34.9 mm	1460-1680	1980-2278	202-232
<b>1-1/2 in</b> 38.1 mm	1940-2200	2631-2983	268-304

<b>Grade 8 Bolts, Nuts, and Studs</b>			
			
Size	Pound-Feet	Newton metres	Kilogram metres
<b>1/4 in</b> 6.4 mm	12-15	16-20	1.7-2.1
<b>5/16 in</b> 7.9 mm	24-29	33-39	3.3-4.0
<b>3/8 in</b> 9.5 mm	45-54	61-73	6.2-7.5
<b>7/16 in</b> 11.1 mm	70-84	95-114	9.7-11.6
<b>1/2 in</b> 12.7 mm	110-132	149-179	15.2-18.2
<b>9/16 in</b> 14.3 mm	160-192	217-260	22.1-26.5
<b>5/8 in</b> 15.9 mm	220-264	298-358	30.4-36.5
<b>3/4 in</b> 19.0 mm	380-456	515-618	52.5-63.0
<b>7/8 in</b> 22.2 mm	600-720	814-976	83.0-99.5
<b>1.0 in</b> 25.4 mm	900-1080	1220-1465	124-149
<b>1-1/8 in</b> 28.6 mm	1280-1440	1736-1953	177-199
<b>1-1/4 in</b> 31.8 mm	1820-2000	2468-2712	252-277
<b>1-3/8 in</b> 34.9 mm	2380-2720	3227-3688	329-376
<b>1-1/2 in</b> 38.1 mm	3160-3560	4285-4827	437-492



## TORQUE SPECIFICATIONS - STEEL HYDRAULIC FITTINGS

Tube OD Hose ID	Thread Size	Pound- Feet	Newton metres	Kilogram metres
<b>37 Degree Flare Fittings</b>				
<b>1/4 in</b> 6.4 mm	7/16-20	6-12	8-16	0.8-1.7
<b>5/16 in</b> 7.9 mm	1/2-20	8-16	11-21	1.1-2.2
<b>3/8 in</b> 9.5 mm	9/16-18	10-25	14-33	1.4-3.5
<b>1/2 in</b> 12.7 mm	3/4-16	15-42	20-56	2.1-5.8
<b>5/8 in</b> 15.9 mm	7/8-14	25-58	34-78	3.5-8.0
<b>3/4 in</b> 19.0 mm	1-1/16-12	40-80	54-108	5.5-11.1
<b>7/8 in</b> 22.2 mm	1-3/16-12	60-100	81-135	8.3-13.9
<b>1.0 in</b> 25.4 mm	1-5/16-12	75-117	102-158	10.4-16.2
<b>1-1/4 in</b> 31.8 mm	1-5/8-12	125-165	169-223	17.3-22.8
<b>1-1/2 in</b> 38.1 mm	1-7/8-12	210-250	285-338	29.0-34.6

Tube OD Hose ID	Thread Size	Pound- Feet	Newton metres	Kilogram metres
<b>Straight Threads with O-ring</b>				
<b>1/4 in</b> 6.4 mm	7/16-20	12-19	16-25	1.7-2.6
<b>5/16 in</b> 7.9 mm	1/2-20	16-25	22-33	2.2-3.5
<b>3/8 in</b> 9.5 mm	9/16-18	25-40	34-54	3.5-5.5
<b>1/2 in</b> 12.7 mm	3/4-16	42-67	57-90	5.8-9.3
<b>5/8 in</b> 15.9 mm	7/8-14	58-92	79-124	8.0-12.7
<b>3/4 in</b> 19.0 mm	1-1/16-12	80-128	108-174	11.1-17.8
<b>7/8 in</b> 22.2 mm	1-3/16-12	100-160	136-216	13.8-22.1
<b>1.0 in</b> 25.4 mm	1-5/16-12	117-187	159-253	16.2-25.9
<b>1-1/4 in</b> 31.8 mm	1-5/8-12	165-264	224-357	22.8-36.5
<b>1-1/2 in</b> 38.1 mm	1-7/8-12	250-400	339-542	34.6-55.3

<b>Split Flange Mounting Bolts</b>			
Size	Pound- Feet	Newton metres	Kilogram metres
5/16-18	15-20	20-27	2.1-2.8
3/8-16	20-25	26-33	2.8-3.5
7/16-14	35-45	47-61	4.7-6.2
1/2-13	55-65	74-88	7.6-9.0
5/8-11	140-150	190-203	19.4-20.7



# Section 1002

## MAINTENANCE AND LUBRICATION

Written In *Clear  
And  
Simple  
English*

## FLUIDS AND LUBRICANTS CHART

COMPONENT	CAPACITY		SPECIFICATIONS
	U.S.	Metric	
Fuel tank	38 gallons	144 litres	See Operators Manual
Cooling system	7 gallons	26 litres	A mixture of half ethylene glycol and half water must be used at all times. If the coldest outside temperature will be less than -34° F (-36° C) add antifreeze.
Crankcase			Case HDM engine oil CD - Commercial Class D Above 32° F (0°) ..... SAE 30 10° to 50° F (-12° to 10° C) ..... SAE 20W20 Below 32° F (0° C) ..... SAE 10W
Without filter change	10 quarts	9.4 litres	
With filter change	11 quarts	10.4 litres	
Hydraulic system			Case TCH Fluid Alternate hydraulic oil: Above 32° F (0° C) ..... SAE 20 SC Below 32° F (0° C) ..... SAE 10W SC
System	21 gallons	80 litres	
Reservoir	16 gallons	61 litres	
Axles			Case FDL Fluid Alternate gear lubricant SAE 85W - 140 API-GL-5
Differential housing	9.5 quarts	9.1 litres	
Planetary	1.5 quarts	1.4 litres	
Transmission			Case TCH Fluid Alternate oil: Type C-2 transmission oil
System	8 gallons	30 litres	
Transmission	6.5 gallons	25 litres	
Alcohol evaporator	1 pint	0.5 litres	Clean methyl alcohol
Batteries	As required		Add drinking water or distilled water
Master cylinders	As required		SAE J1703c (DOT 3) brake fluid
Grease fittings	As required		Molydisulfide multipurpose grease



INTERVAL	SERVICE	INSTRUCTIONS
Every 150 hours of operation	Change engine oil; machines without turbocharger.	
Every 200 hours of operation	Change filters for engine oil; engines with turbochargers.	
Every 250 hours of operation	<p>Check level of gear lubricant in axles.</p> <p>Lubricate pivot points for loader, bucket, and clam control levers.</p> <p>Clean filter in alcohol evaporator, if equipped.</p> <p>Lubricate pivot points for suspension seat, if equipped.</p> <p>Check brake lining thickness; machines with disc brakes.</p>	<p>Section 6126</p> <p>Section 9064</p> <p>Section 7122</p>
Every 300 hours of operation	Change filter for engine oil; engines without turbocharger.	
After 500 hours of operation	<p>Check tension of drive belts.</p> <p>Replace fuel filters.</p> <p>Clean filter in electric fuel pump.</p> <p>Replace filter for transmission oil.</p> <p>Replace filters for hydraulic oil.</p> <p>Inspect ROPS cab or ROPS canopy.</p>	<p>Section 4007, 7103 and 9003</p> <p>Section 3010</p> <p>Section 3002</p> <p>Section 6102</p> <p>Section 8002</p> <p>Section 9061</p>
After 1000 hours of operation	<p>Change hydraulic oil.</p> <p>Clean suction screen in reservoir for hydraulic oil.</p> <p>Change transmission oil.</p> <p>Clean suction screen in transmission.</p> <p>Clean breather for transmission.</p> <p>Change gear lubricant in each axle.</p> <p>Clean cylinder head for air compressor.</p>	<p>Section 8002</p> <p>Section 8002</p> <p>Section 6102</p> <p>Section 6102</p> <p>Section 6102</p> <p>Section 6126 or 6127</p> <p>Section 7103</p>

INTERVAL	SERVICE	INSTRUCTIONS
After 2000 hours of operation or yearly, whichever occurs first	Clean the cooling system. Fill cooling system with new coolant.  Drain water and sediment from fuel tank.  Disassemble and clean alcohol evaporator, if equipped.  Check refrigerant charge in air conditioning system, if equipped.	See Fluids and Lubricants Chart   Section 7111  Section 9003
After 3000 hours of operation	Replace or overhaul the air compressor.	Section 7103
As required	Service the air cleaner  Replace filters for hydraulic oil when warning lamp is illuminated.  Tighten wheel nuts to correct torque value after wheel is removed and installed.	Section 2000  Section 8002  Section 6129





# **Section 1010**

## **GENERAL ENGINE SPECIFICATIONS**

**W14 Loader**

**P.I.N. 9119672 and After**

**336BD DIESEL ENGINE**

## General

Type	4 Cylinder, 4 Stroke Cycle, Valve-In-Head
Firing Order	1-3-4-2
Bore	4-5/8 Inches (117.48 mm)
Stroke	5 Inches (127 mm)
Piston Displacement	336 Cubic Inches (5 506 cm <sup>3</sup> )
Compression Ratio	16 to 1
No Load Governed Speed	2330 to 2370 RPM
Rated Engine Speed	2200 RPM
Engine Idling Speed	700 to 750 RPM
Exhaust Valve Rotators	Positive Type
Valve Tappet Clearance (Exhaust)	(COLD) 0.025 Inch (0.635 mm)
(Intake)	(COLD) 0.015 Inch (0.381 mm)
Thermostat Operating Range	175° F to 202° F (79° C to 94° C)

## Piston And Connecting Rods

Rings Per Piston	3
Number of Compression Rings	2
Number of Oil Rings	1
Type Pins	Full Floating Type
Type Bearing	Replaceable Precision, Steel Back, Copper-Lead Liners

## Main Bearings

Number of Bearings	5
Type Bearings	Replaceable Precision, Steel Back, Copper-Lead Liners

## Engine Lubricating System

Crankcase Capacity (Without Filter Change)	12 Quarts (11.4 Litres)
(With Filter Change)	13 Quarts (12.4 Litres)
Oil Pressure	45 to 60 PSI (310 to 414 kPa)(3.10 to 4.14 bar) With Engine Warm and Operating At Rated Engine Speed
Type System	Pressure And Spray Circulation
Oil Pump	Gear Type
Oil Filter	Full Flow Turn On Type

## Fuel System

Fuel Injection Pump	Robert Bosch, Type PES Multiple Plunger
Pump Timing	27 Degrees Before Top Center
Fuel Injectors	17 mm Type, Opening Pressure (New) 3950 to 4100 PSI (27 235 to 28 270 kPa)
Fuel Transfer Pump	Plunger Type, Integral Part Of Injection Pump
Governor	Variable Speed, Fly-Weight Centrifugal Type, Integral Part Of Injection Pump
1st Stage Fuel Filter	Full Flow Turn On Type
2nd Stage Fuel Filter	Full Flow Turn On Type

# Section 1023

## SPECIFICATION DETAILS 336BD AND 336BDT ENGINE

Written In *Clear  
And  
Simple  
English*

**FRACTION to DECIMAL to MILLIMETER CONVERSION TABLE**

Fraction	Decimal	MM	Fraction	Decimal	MM	Fraction	Decimal	MM
1/64	.0156	0.397	23/64	.3593	9.128	45/64	.7031	17.859
1/32	.0312	0.794	3/8	.3750	9.525	23/32	.7187	18.256
3/64	.0468	1.191	25/64	.3906	9.922	47/64	.7343	18.653
1/16	.0625	1.587	13/32	.4062	10.319	3/4	.7500	19.050
5/64	.0781	1.984	27/64	.4218	10.716	49/64	.7656	19.447
3/32	.0937	2.381	7/16	.4375	11.113	25/32	.7812	19.844
7/64	.1093	2.778	29/64	.4531	11.509	51/64	.7968	20.240
1/8	.1250	3.175	15/32	.4687	11.906	13/16	.8125	20.637
9/64	.1406	3.572	31/64	.4843	12.303	53/64	.8281	21.034
5/32	.1562	3.969	1/2	.5000	12.700	27/32	.8437	21.431
11/64	.1718	4.366	33/64	.5156	13.097	55/64	.8593	21.828
3/16	.1875	4.762	17/32	.5312	13.494	7/8	.8750	22.225
13/64	.2031	5.159	35/64	.5468	13.890	57/64	.8906	22.622
7/32	.2187	5.556	9/16	.5625	14.287	29/32	.9062	23.019
15/64	.2343	5.953	37/64	.5781	14.684	59/64	.9218	23.415
1/4	.2500	6.350	19/32	.5937	15.081	15/16	.9375	23.812
17/64	.2656	6.747	39/64	.6093	15.478	61/64	.9531	24.209
9/32	.2812	7.144	5/8	.6250	15.875	31/32	.9687	24.606
19/64	.2968	7.541	41/64	.6406	16.272	63/64	.9843	25.003
5/16	.3125	7.937	21/32	.6562	16.669	1	1.0000	25.400
21/64	.3281	8.334	43/64	.6718	17.065			
11/32	.3437	8.731	11/16	.6875	17.462			

**INCH to MILLIMETER CONVERSION TABLE**

Inch	MM	Inch	MM	Inch	MM	Inch	MM
1	25.400	6	152.000	10	254.000	60	1,524.000
2	50.800	7	177.800	20	508.000	70	1,778.000
3	76.200	8	203.200	30	762.000	80	2,032.000
4	101.600	9	228.600	40	1,016.000	90	2,286.000
5	127.000	10	254.000	50	1,270.000	100	2,540.000