

SHOP MANUAL

CASE/INTERNATIONAL

MAGNUM SERIES

MODELS

7110-7120-7130-7140

IDENTIFICATION

Tractor model number and identification serial number are located on a plate on lower left side of instrument panel cover. Engine serial number is located on a plate on left side of timing gear housing. Cab serial number is located on a plate just to the left of inching pedal. Transmission serial number is located on a plate on right front side of speed transmission housing. On models so equipped, front-wheel drive serial number is located on a plate on right rear side of front drive axle housing.

INDEX (By Starting Paragraph)

	Models			
	7110	7120	7130	7140
AFTER COOLER	71
AIR CLEANER SYSTEM ..	72	72	72	72
AXLE, FRONT (TWO WHEEL DRIVE)				
Axle Main Member	4	4	4	4
Front Support	5	5	5	5
Spindles	2	2	2	2
Tie Rod & Toe-In	3	3	3	3
Wheel Bearings	1	1	1	1
BRAKES				
Adjustment	178	178	178	178
Bleed System	181	181	181	181
Brake Cylinders	179	179	179	179
Control Valve	180	180	180	180
CAB				
Remove & Reinstall	228	228	228	228
COOLING SYSTEM				
Belt Tensioner	75	75	75	75
Fan	74	74	74	74
Filter & Conditioner	78	78	78	78
Radiator	73	73	73	73
Thermostat	77	77	77	77
Water Pump	76	76	76	76

INDEX (CONT.)

	Models			
	7110	7120	7130	7140
DIESEL FUEL SYSTEM				
Bleed System	55	55	55	55
Ether Starting Aid	67	67	67	67
Fuel, Filters & Transfer				
Pump	52,53,54	52,53,54	52,53,54	52,53,54
Fuel Solenoid Shut-Off	66	66	66	66
Injection Pump	56	56	56	56
Injector Nozzle	59	59	59	59
Timing	57	57	57	57
DIFFERENTIAL (REAR)				
R&R and Overhaul	171	171	171	171
DIFFERENTIAL LOCK				
Control Valve	175	175	175	175
ELECTRICAL SYSTEM				
Accessory Systems	95	95	95	95
Alternator	85	85	85	85
Batteries	79	79	79	79
Cab Fan	130	130	130	130
Charging System	81	81	81	81
Digital Instrument Cluster ..	96	96	96	96
Heater & Air Conditioning .	131	131	131	131
Protective Circuits	93	93	93	93
Starting Motor	88	88	88	88
Windshield Wiper	129	129	129	129
ENGINE				
Cam Followers	30	30	30	30
Camshaft	37	37	37	37
Connecting Rods &				
Bearings	42	42	42	42
Crankshaft & Bearings	43	43	43	43
Cylinder Head	25	25	25	25
Cylinder Sleeves	40	40	40	40
Flywheel	47	47	47	47
Main Bearings	43	43	43	43
Oil Pan	48	48	48	48
Oil Pump	49	49	49	49
Piston & Rod Removal	39	39	39	39
Piston Pins & Bushings	41	41	41	41
Pistons & Rings	40	40	40	40
Remove & Reinstall Engine				
Assembly	24	24	24	24
Timing Gear Cover	31	31	31	31
Timing Gears	32	32	32	32
Valve Adjustment	27	27	27	27
Valve Guides & Springs ...	28	28	28	28
Valves & Seats	26	26	26	26

INDEX (CONT.)

	Models			
	7110	7120	7130	7140
FINAL DRIVES				
Overhaul	177	177	177	177
Remove & Reinstall	176	176	176	176
FRONT-WHEEL DRIVE				
Differential	11	11	11	11
Front Drive Shaft	12	12	12	12
Front Support	7	7	7	7
Pivot Housing & Axle shaft	10	10	10	10
R&R Drive Axle Assy.	6	6	6	6
Tie Rod & Toe-In	8	8	8	8
Wheel Hub & Planetary	9	9	9	9
HYDRAULIC LIFT SYSTEM				
Electronic Diagnostic				
Codes	203	203	203	203
Control Circuit Tests	204	204	204	204
Control Valve	221	221	221	221
Hitch Adjustments	216	216	216	216
Hitch Lift Assist Cylinders .	223	223	223	223
Lift Housing	222	222	222	222
Operation	200	200	200	200
HYDRAULIC SYSTEM				
Priority Valve	198	198	198	198
Pto Control Valve	199	199	199	199
Pump Compensator Valve ..	196	196	196	196
Pump Drive Unit	197	197	197	197
Pumps	193	193	193	193
Remote Control Valves	224	224	224	224
PARK LOCK				
Linkage Adjustment	182	182	182	182
Overhaul Park Lock	183	183	183	183
POWER SHIFT				
Adjustment	134	134	134	134
Control Valve	138	138	138	138
Power Shift Operation	133	133	133	133
Speed Transmission, Overhaul	150	150	150	150
Range Transmission, Overhaul	161	161	161	161
POWER STEERING SYSTEM				
Fluid, Filters & Bleeding ...	13	13	13	13
Hand Pump	20	20	20	20
Operational Tests	16	16	16	16
Steering Cylinder	22,23	22,23	22,23	22,23
System Pressure	15	15	15	15
Trouble-Shooting	14	14	14	14

INDEX (CONT.)

	Models			
	7110	7120	7130	7140
POWER TAKE-OFF				
Clutch Overhaul	188,191	188,191	188,191	188,191
Control Valve	186	186	186	186
Linkage Adjustment	184	184	184	184
Overhaul Dual Shaft	190	190	190	190
Overhaul Single Shaft	189	189	189	189
Pressure Adjustment	185	185	185	185
Rear Unit, R&R	187	187	187	187
Reduction Gears	192	192	192	192
TURBOCHARGER				
Operation	68	68	68	68
Overhaul	70	70	70	70
Remove & Reinstall	69	69	69	69

DUAL DIMENSIONS

This service manual provides specifications in both the U.S. Customary and Metric (SI) system of measurements. The first specification is given in the measuring system used during manufacture, while the second specification (given in parenthesis) is the converted measurement. For instance, a specification of "0.011 inch (0.279 mm)" would indicate that the equipment was manufactured using the U.S. system of measurement and the metric equivalent of 0.011 inch is 0.279 mm.

CONDENSED SERVICE DATA

	Models			
	7110	7120	7130	7140
GENERAL				
Engine Make	Case-International			
Engine Model	6T-830		6TA-830	
Cylinders, No. of	6			
Bore	4.488 in. (114 mm)			
Stroke	5.315 in. (135 mm)			
Displacement	505 cu. in. (8.3 L)			
Compression Ratio	17.3:1		16.5:1	
Main Bearings, No. of	7			
Cylinder Sleeves	Wet			
Forward Speeds	18 or 24			
TUNE-UP				
Firing Order	1-5-3-6-2-4			
Valve Tappet Gap, Cold—				
Intake	0.012 in. (0.305 mm)			
Exhaust	0.024 in. (0.609 mm)			

CONDENSED SERVICE DATA (CONT.)

	Models			
	7110	7120	7130	7140
TUNE-UP (CONT.)				
Injection Pump—				
Make	Robert Bosch			
Model		PS6A		PS6MW
Timing	TDC			
Injection Nozzles—				
Make	Robert Bosch 17 mm			
Opening Pressure,				
New	2968-3084 psi (20464-21263 kPa)			
Used	2722-3084 psi (18768-21263 kPa)			
Turbocharger—				
Make	Holset			
Engine Governed Speeds (Rpm)—				
Low Idle	825-875			
High Idle	2315-2395			
Rated Load	2200			
Battery Terminal Grounded	Negative			
CAPACITIES				
Cooling System	30 U.S. qts. (28.6 L)		31 U.S. qts. (29.3 L)	
Crankcase (w/filters)	22 U.S. qts. (21 L)			
Transmission & Hydraulic				
System	202 U.S. qts. (191 L)			
Oil Type	Hy-Tran Plus			
Fuel Tank	78 U.S. gal.* (295 L)*	78 U.S. gal.* (295 L)*	95 U.S. gal. (359 L)	95 U.S. gal. (359 L)
Front Drive Axle—				
Differential (Axle) Housing	Refer to paragraph 11.			
Oil Type	Case IH 135 HEP or SAE 85W-140			
Planetary (Each Side)	1 U.S. qt. (0.9 L)			
Oil Type	Case IH 135 HEP or SAE 85W-140			

*95 U.S. gallons (359 liters) with auxiliary tank.

FRONT AXLE (TWO-WHEEL DRIVE)

FRONT WHEEL BEARINGS

All Models

1. Refer to Fig. 1 for typical wheel hub and bearing assembly. The tapered inner and outer roller bearings are not interchangeable. Clean and inspect bearing cups and cones and renew as necessary.

Install dust shield (2) outer flange toward hub and with open section on the bottom. Install oil seal (3) on the spindle (1) so that metal face of seal is toward the hub. Press bearing cups (6) into hub until seated. Pack bearing cones (5 and 8) with No. 2 lithium grease and install bearing cone (5) in hub. Install hub wear ring (4) into hub until outer flange contacts hub. Coat lips of seal (3) with grease and install hub onto spindle. Install outer bearing cone (8), washer (9) and nut (10). Tighten nut to a torque of 15 ft.-lbs. (20 N·m) while rotating hub. Back off nut to first slot where cotter pin can be installed. Install cotter pin and cap (12). Lubricate the assembly through lube fitting (13). Install wheel and tire assembly and tighten lug bolts to a torque of 140-160 ft.-lbs. (190-220 N·m).

SPINDLES

All Models

2. **R&R SPINDLES.** To remove either spindle, lift and support front of tractor and remove wheel. Disconnect tie rod ball joint (9—Fig. 2) from steering arm (5). Remove cap screw (3) and washer (4). If not marked, install alignment punch marks on steering arm and spindle. Remove steering arm (5) and lower spindle assembly (11) from axle extension (7). Remove thrust bearing (10) from spindle. Inspect spindle bushings (6 and 8) in axle extension and renew as necessary.

If removed, install bushings (6 and 8) into axle extension with open end of oil grooves in bushings toward inside. Install bushings until recessed 0.157 inch (4 mm) below flush with top and bottom. New bushings are presized and should not require reaming if carefully installed.

Install thrust bearing (10) on spindle (11), then install spindle into axle extension. Align punch marks and install steering arm (5) on spindle. Apply Loctite 262 on threads of cap screw (3), then install cap screw and washer (4). Connect tie rod end to steering arm and tighten nut (1) to a torque of 100 ft.-lbs. (136 N·m). Secure with cotter pin (2). Install wheel and tire assembly and tighten lug bolts to a torque of 140-160 ft.-lbs. (190-220 N·m). Lubricate with Case/IH 251EP or equivalent No. 2 multipurpose lithium grease.

TIE RODS AND TOE-IN

All Models

3. Removal and disassembly of the tie rods is obvious after examination of the unit and reference to Fig. 2. Tighten tie rod end slotted nuts to a torque of 100 ft.-lbs. (136 N·m) and install new cotter pins. Tighten clamp bolts to a torque of 40-50 ft.-lbs. (55-70 N·m).

Front wheel toe-in must be 0.187-0.312 inch (4.7-7.9 mm). To adjust toe-in, remove clamp bolts from tie rod extension. Loosen jam nut, then rotate extension in or out to obtain correct toe-in. Install clamp bolts and tighten jam nut. Recheck toe-in and readjust if necessary. Both tie rods should be approximately the same length.

AXLE MAIN MEMBER

All Models

4. To remove the axle main member (6—Fig. 3), first raise and support tractor under engine side rails with

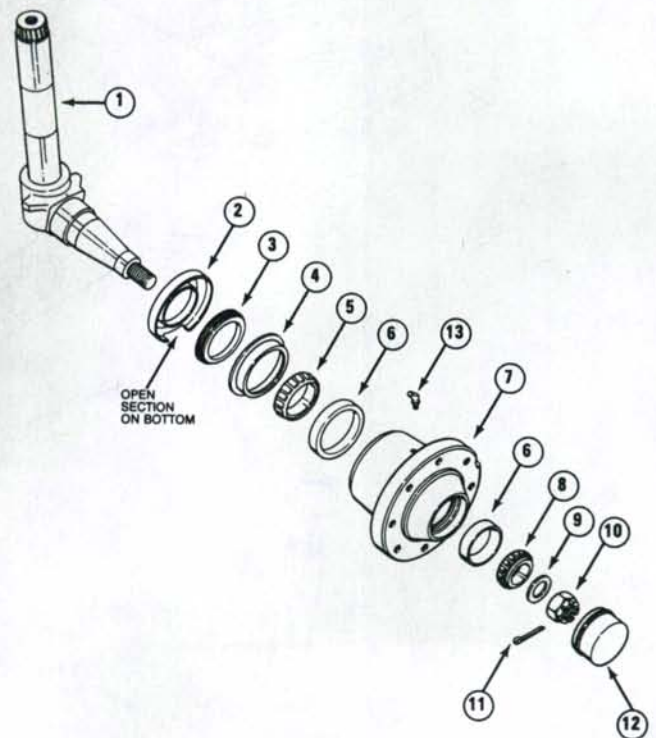

Fig. 1—Exploded view of front wheel hub and bearing assembly used on all two-wheel drive tractors.

- | | |
|-------------------------|-------------------------|
| 1. Spindle | 8. Bearing cone (outer) |
| 2. Dust shield | 9. Washer |
| 3. Oil seal | 10. Nut |
| 4. Hub wear ring | 11. Cotter pin |
| 5. Bearing cone (inner) | 12. Cap |
| 6. Bearing cups | 13. Lube fitting |
| 7. Hub | |

Paragraph 4 (Cont.)

CASE/INTERNATIONAL

suitable split stands (CAS-10749 or equivalent). If so equipped, remove front weights and weight bracket. Disconnect and remove tie rods, then disconnect steering cylinder from lug on axle main member and center steering arm. Tie cylinder assembly up out of the way, being careful not to damage steering cylinder hoses. Remove bolts (10) and using a hoist, remove axle extension (12), spindle and wheel from both sides.

Place a floor jack under axle main member (6). Remove cap screw (1), flat washer (2) and spacer (3). Remove front grease fitting and install a slide hammer to pivot shaft (4). Support weight of axle with floor jack and withdraw pivot shaft from front support (5). Catch thrust washers (7 and 8) as shaft is withdrawn. Lower axle main member to clear front support and roll forward from tractor.

Drive out roll pin (14) from pivot pin (20). Withdraw pivot pin, then carefully remove center steering arm (19) with shim washers (15 and 16) and "O" rings (17). Inspect bushings (18) and renew as required. Press new bushings in from top and bottom of steering arm until they are recessed 0.196 inch (5 mm) below flush. Lubricate new "O" rings (17) with petroleum jelly and install in recesses above and below bushings. Install

two 0.156 inch (3.96 mm) thick shim washers below steering arm and one 0.156 inch (3.96 mm) and one 0.042 inch (1.067 mm) shim washer above steering arm. Reinstall center steering arm assembly and pivot pin. Measure clearance between upper washer (15) and axle main member. If clearance is more than 0.042 inch (1.067 mm), add shim washers (16) as required to obtain clearance of less than 0.042 inch (1.067 mm). Secure pivot pin (20) with new roll pin (14).

Axle pivot bushings (9) can now be removed using a suitable drift punch. Drive new bushings into bore of axle main member until $\frac{1}{16}$ inch (1.6 mm) below outer surface. When reassembling, coat pivot shaft (4) and bushings with anti-seize compound. Install one steel washer (7), one nylon washer (8) and second steel washer (7) at front and rear of axle main member. Install pivot shaft, then check axle main member end clearance. If end clearance exceeds 0.059 inch (1.5 mm), add steel washer (7) at rear side of axle. Install spacer (3), flat washer (2) and cap screw (1). Tighten cap screw to a torque of 65-75 ft.-lbs. (90-100 N·m).

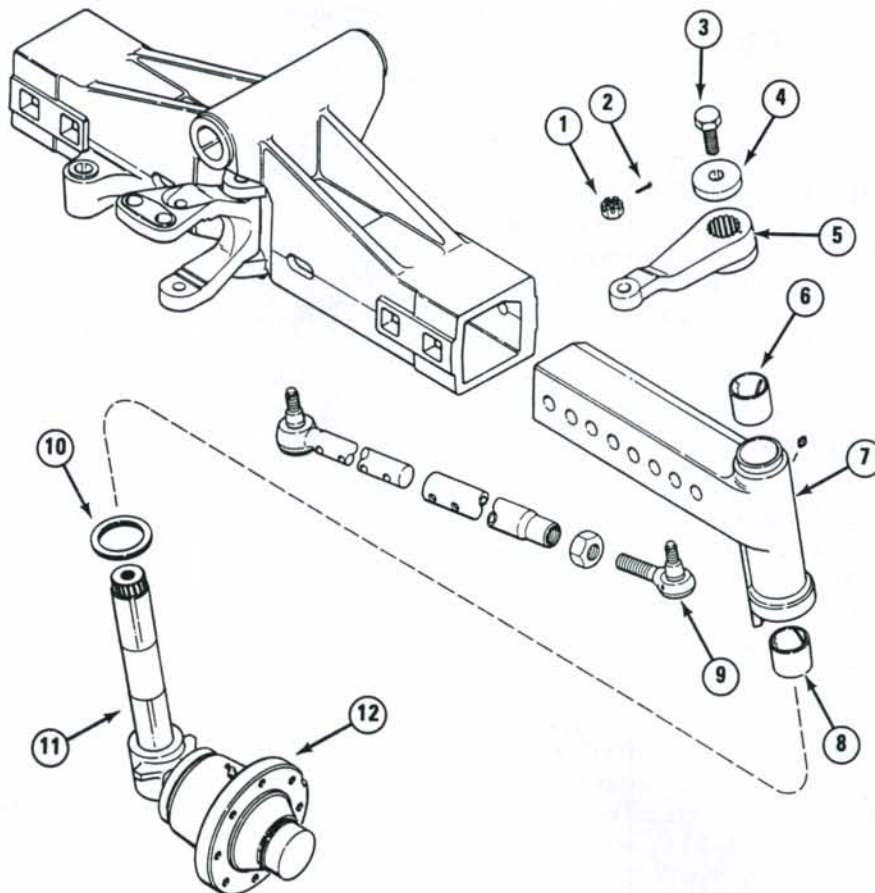

Fig. 2—Exploded view showing axle extension, spindle and bushings used on all two-wheel drive tractors.

- | | | | |
|---------------|--------------------|--------------------|--------------------|
| 1. Nut | 4. Washer | 7. Axle extension | 10. Thrust bearing |
| 2. Cotter pin | 5. Steering arm | 8. Bushing (lower) | 11. Spindle |
| 3. Cap screw | 6. Bushing (upper) | 9. Tie rod end | 12. Hub assy. |

The balance of reassembly is the reverse of disassembly procedure. Tighten axle extension bolts (10) to a torque of 375-425 ft.-lbs. (510-575 N.m).

FRONT SUPPORT

All Models

5. REMOVE AND REINSTALL. To remove the front support (5—Fig. 3), first remove hood, grille and side panels. Disconnect air intake hose. Drain radiator and disconnect front wiring harness connector. Disconnect upper and lower radiator hoses, coolant filter hose and coolant recovery hose. Disconnect ether starting line from intake manifold. Remove hoses from clip on radiator, then remove air conditioning condenser and lay back on top of engine. Identify and disconnect oil cooler lines and remove oil cooler. Attach a hoist with lift straps to radiator support. Unbolt radiator support from front support and tilt radiator forward to clear fan as the assembly is removed.

If so equipped, remove front weights and weight bracket. Remove front axle assembly as in paragraph 4, but do not separate axle extensions from axle main member. Attach a hoist to front support, unbolt from side rails and slide support forward from tractor.

Reinstall by reversing the removal procedure. Tighten side rail to front support bolts to a torque of 162-184 ft.-lbs. (220-250 N.m). Tighten the five cap screws securing radiator support to front support to a torque of 34-38 ft.-lbs. (46-52 N.m).

FRONT DRIVE AXLE

All models are available with a Spicer front drive axle. Front drive axle can be engaged or disengaged with tractor on the go. Front drive axle is spring clutch engaged and hydraulically disengaged. The solenoid control valve is located on left side of rear frame housing and is identical to the rear differential lock valve. Refer to paragraph 175 for service information. Unit is equipped with a limited slip differential.

NOTE: The front drive axle clutch is located in the RANGE transmission housing and the clutch output shaft is located in the SPEED transmission housing. Refer to these sections for R&R AND OVERHAUL procedures.

DRIVE AXLE ASSEMBLY

Models So Equipped

6. REMOVE AND REINSTALL. To remove front drive axle assembly (8—Fig. 4), place shift control

lever in PARK position and block rear wheels securely. If so equipped, remove front weights and weight bracket. Loosen front wheel lug nuts. Raise hood and remove side panels. Install front split stands, CAS-10749 or equivalent, to side rails. Raise front of tractor and remove front wheels. Install axle carrier CAS-10500-4 to support drive axle. Unbolt front of drive shaft shield (10) and slide shield rearward. Unbolt front drive shaft "U" joint (9) and lower front end of drive shaft. Disconnect steering cylinder hoses and plug or cap all openings to prevent entrance of dirt into system. Remove cap screw (1) and washer (2), then remove pivot shaft (3). Catch washers (5 and 6) as shaft is withdrawn. Lower axle carrier and remove axle assembly forward from tractor.

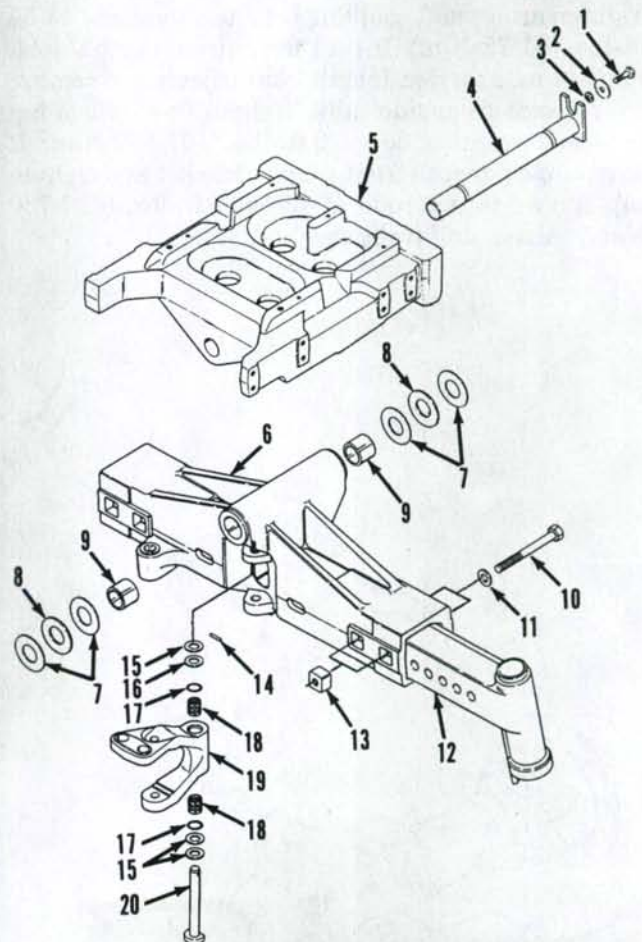

Fig. 3—Exploded view of axle main member, front support and related parts used on all two-wheel drive tractors.

- | | |
|--------------------------|----------------------------------|
| 1. Cap screw | 12. Axle extension |
| 2. Flat washer | 13. Square nut |
| 3. Spacer | 14. Roll pin |
| 4. Pivot shaft | 15. Washer, 0.156 in. (3.96 mm) |
| 5. Front support | 16. Washer, 0.042 in. (1.067 mm) |
| 6. Axle main member | 17. "O" Ring |
| 7. Washer (steel) | 18. Bushing |
| 8. Thrust washer (nylon) | 19. Center steering arm |
| 9. Pivot bushings | 20. Pivot pin |
| 10. Bolt | |
| 11. Washer | |

Paragraphs 7-9

Inspect bushings (7) and renew as necessary. When installing new bushings, apply a coat of Loctite anti-seize to bore in axle housing. Freeze bushings in dry ice and carefully install flush to $\frac{1}{16}$ inch (1.6 mm) below the face of axle housing.

Inspect thrust washers (5 and 6) for excessive wear and renew as necessary. Reinstall axle assembly to front support. Make sure that nylon thrust washer (6) is installed between steel thrust washers (5) at both front and rear sides of axle. Use as many additional steel washers as possible at rear side of axle housing to shim axle housing forward. Secure pivot shaft (3) in place with washer (2) and cap screw (1), tightened to a torque of 93-112 ft.-lbs. (126-152 N.m). Connect steering cylinder lines and reinstall front drive shaft. Tighten drive shaft coupling bolts to a torque of 45-54 ft.-lbs. (61-73 N.m). Install front drive shaft shield. Remove axle carrier. Install front wheels and remove split stands from side rails. Tighten front wheel lug nuts to a torque of 300-370 ft.-lbs. (407-502 N.m). If so equipped, install front weight bracket and tighten cap screws to a torque of 450-540 ft.-lbs. (610-730 N.m), then install front weights.

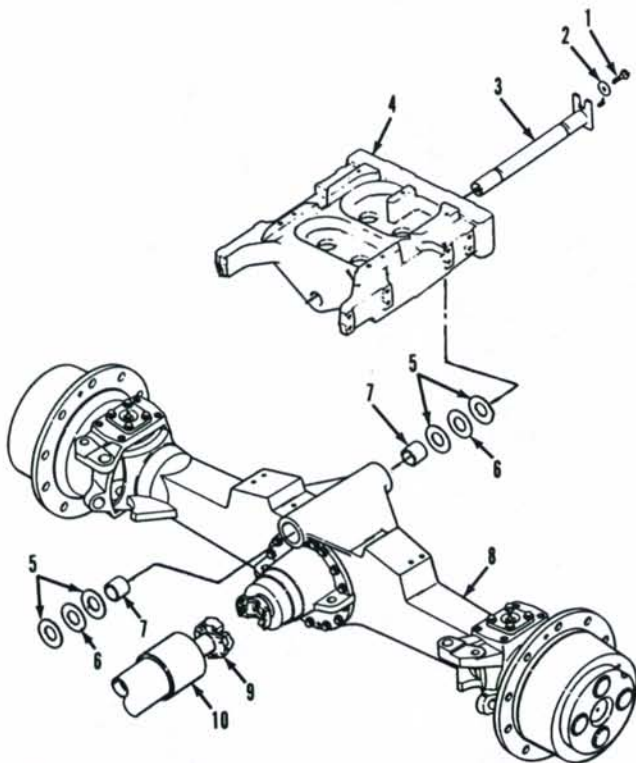

Fig. 4—View of front drive axle and front support removed from tractor.

- | | |
|-------------------|--------------------------|
| 1. Cap screw | 6. Thrust washer (nylon) |
| 2. Flat washer | 7. Bushings |
| 3. Pivot shaft | 8. Drive axle assy. |
| 4. Front support | 9. Front drive shaft |
| 5. Washer (steel) | 10. Drive shaft shield |

CASE/INTERNATIONAL

FRONT SUPPORT

Models So Equipped

7. REMOVE AND REINSTALL. To remove front support (4—Fig. 4), first remove hood, grille and side panels. Disconnect air intake hose. Drain radiator and disconnect front wiring harness connector. Disconnect upper and lower radiator hoses, coolant air bleed hose and coolant recovery hose. Disconnect ether starting line from intake manifold. Remove hoses from clip on radiator, then remove air conditioning condenser and lay back on top of engine. Identify and disconnect oil cooler lines and remove oil cooler. Attach a hoist with lift straps to radiator support. Unbolt radiator support from front support and tilt radiator forward to clear fan as the assembly is removed.

If so equipped, remove front weights and weight bracket. Remove front drive axle assembly as outlined in paragraph 6. Attach a hoist to front support, unbolt from side rails and slide front support forward from tractor.

Reinstall by reversing removal procedure. Tighten side rail to front support bolts to a torque of 162-184 ft.-lbs. (220-250 N.m). Tighten the five cap screws securing radiator support to front support to a torque of 34-38 ft.-lbs. (46-52 N.m).

TIE ROD AND TOE-IN

Models So Equipped

8. Due to the closeness between tie rod and front support, removal of tie rod and toe-in adjustment can be accomplished only after removal of front drive axle assembly as outlined in paragraph 6. Disassembly of tie rod is obvious after removal and reference to Fig. 5. Toe-in should be adjusted to 0-0.5 inch (0-12.7 mm). One full turn of a tie rod end (2 or 6) will change toe-in $\frac{3}{8}$ inch (9.5 mm). Make sure bow of tie rod tube (4) is down.

Tighten slotted nuts (1) to a torque of 140 ft.-lbs. (190 N.m). Tighten jam nuts (3 and 5) to a torque of 250-300 ft.-lbs. (340-405 N.m).

WHEEL HUB AND PLANETARY

Models So Equipped

9. R&R AND OVERHAUL. To remove the wheel hub and planetary, support axle housing and remove front wheel and tire assembly. Rotate wheel hub until drain plug (13—Fig. 6) is at bottom.

NOTE: Front drive shaft must be disconnected before wheel hub can be rotated.

Remove drain plug and allow oil to drain. Remove the two socket head cap screws (14), then remove planetary carrier (12). Withdraw sun gear (11). Remove the three cap screws (10), retaining plate (9) and shim (8), then lift off ring gear (21). Remove wheel hub (4). Remove bearing cone (6) from ring gear (21). Remove oil seal (1), inner bearing cone (2), "O" ring (7) and, if necessary, bearing cups (3 and 5) from wheel hub (4).

Remove retaining rings (20), spacers (16) and planetary gears (18) with needle rollers (17) and spacers (19). Clean and inspect all parts and renew as necessary. Needle rollers (17) are available in a set of 376 and planetary gears (18) are available in a set of four.

Install first spacer plate (16) over pin in planetary carrier (12). Use petroleum jelly to hold needle rollers in place and install two rows of needle rollers in gear (18) with spacer (19) between the two rows. Install planetary gear and needle roller assembly over pin in planetary carrier. When all four planetary gears and needle rollers are installed, install second spacer plate (16) and secure with retaining rings (20).

If removed, install bearing cups (3 and 5) in hub. Heat bearing cone (6) in a bearing oven to a temperature of 250° F (120° C) and install on ring gear (21) until seated.

WARNING: Always wear heat protective gloves when handling heated parts.

Install bearing cone (2), but do not install oil seal (1) at this time. Install Hub (2) on pivot housing and install ring gear (21) and retaining plate (9) without shims (8). Tighten cap screws (10) evenly to a torque

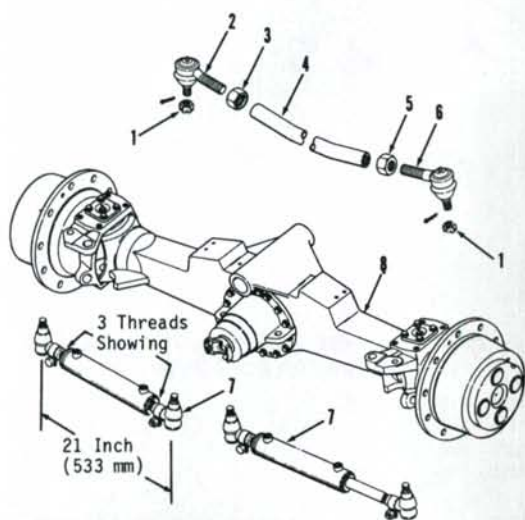

Fig. 5—Front drive axle, tie rod and steering cylinders removed from tractor.

- | | |
|----------------------------|----------------------------|
| 1. Slotted nut | 5. Jam nut |
| 2. Tie rod end (LH thread) | 6. Tie rod end (RH thread) |
| 3. Jam nut | 7. Steering cylinders |
| 4. Tie rod tube | 8. Drive axle assy. |

of 20 ft.-lbs. (27 N.m). Use a torque wrench and special tool CAS-1768 as shown in Fig. 7, to check rolling torque of hub. Tighten or loosen cap screws (10—Fig. 6) until rolling torque is 50-90 in.-lbs. (6-10 N.m). Then, using a depth micrometer through hole in retaining plate (9), measure distance from outer face of plate to end of pivot housing. See Fig. 8. Record this measurement. Remove retaining plate and measure thickness of the plate. Subtract this measurement from the first measurement. The difference will be the correct thickness of shim pack (8—Fig. 6) to be installed. Shims are available in thicknesses of 0.001, 0.002, 0.005, 0.010, 0.020 and 0.030 inch (0.0254, 0.0508, 0.127, 0.254, 0.508 and 0.762 mm). Remove sun gear (11), ring gear (21) and hub (4). Install new oil seal (1) in hub with lip facing away from bearing (2). Reinstall hub, ring gear, correct shim pack and retaining plate. Install cap screws (10) and tighten to a torque of 65-75 ft.-lbs. (88-102 N.m). Install sun gear (11) and new "O" ring (7). Align holes for socket head screws (14) and install planetary carrier (12). Install socket head screws (14) and tighten securely. Rotate hub until oil level arrow points downward. Remove plug (13) and fill planetary unit to level plug

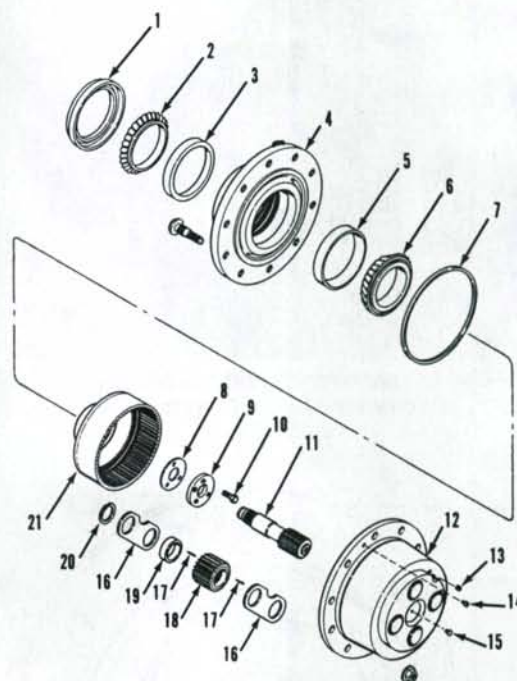

Fig. 6—Exploded view of wheel hub and planetary unit used on front drive axle.

- | | |
|-------------------------|---------------------------|
| 1. Oil seal | 12. Planetary carrier |
| 2. Bearing cone (inner) | 13. Plug |
| 3. Bearing cup | 14. Socket head screw (2) |
| 4. Hub | 15. Plug |
| 5. Bearing cup | 16. Spacer |
| 6. Bearing cone (outer) | 17. Needle rollers |
| 7. "O" Ring | 18. Planetary gear |
| 8. Shim | 19. Spacer |
| 9. Retaining plate | 20. Retaining ring |
| 10. Cap screw (3) | 21. Ring gear |
| 11. Sun gear | |