

---

# HYDRAULIC EXCAVATOR CX130

---



CASE TRAINING CENTRE  
AUGUST 2000





---

# HYDRAULIC EXCAVATOR CX130

---



## SECTION N°1 GENERALE INTRODUCTION

CASE TRAINING CENTRE  
AUGUST 2000





# GENERAL INFORMATION

## **Cleaning**

Clean all metal parts except bearings, in a suitable cleaning solvent or by steam cleaning. Do not use caustic soda for steam cleaning. After cleaning, dry and put oil on all parts. Clean oil passages with compressed air. Clean bearings in a suitable cleaning solvent, dry the bearings completely and put oil on the bearings.

## **Inspection**

Check all parts when the parts are disassembled. Replace all parts that have wear or damage. Small scoring or grooves can be removed with a hone or crocus cloth. Complete a visual inspection for indications of wear, pitting and the replacement of parts necessary to prevent early failures.

## **Bearings**

Check bearings for easy action. If bearings have a loose fit or rough action replace the bearing. Wash bearings with a suitable cleaning solvent and permit to air dry. **DO NOT DRY BEARINGS WITH COMPRESSED AIR.**

## **Needle bearings**

Before you press needle bearings in a bore always remove any metal protrusions in the bore or edge of the bore. Before you press bearings into position put petroleum jelly on the inside and outside diameter of the bearings.

## **Gears**

Check all gears for wear and damage. Replace gears that have wear or damage.

## **Oil seals, O-rings and gaskets**

Always install new oil seals, O-rings and gaskets. Put petroleum jelly on seals and O-rings.

## **Shafts**

Check all shafts that have wear or damage. Check the bearing and oil seal surfaces of the shafts for damage.

## **Service parts**

Always install genuine Case service parts. When ordering refer to the Parts Catalog for the correct part number of the genuine Case replacement items. Failures due to the use of other than genuine Case replacement parts are not covered by warranty.

## **Lubrication**

Only use the oils and lubricants specified in the Operator's or Service Manuals. Failures due to the use of non-specified oils and lubricants are not covered by warranty.

# GENERAL INFORMATION

## SAFETY



**WARNING:** This symbol means ATTENTION! BECOME ALERT! YOUR SAFETY IS INVOLVED. The message that follows the symbol contains important information about safety. Carefully read the message. Make sure you fully understand the causes of possible injury or death.

To prevent injury always follow the Warning, Caution and Danger notes in this section and throughout the manual.

Place a "Do not operate" tag on the starter switch key before carrying out any service or repair work on the machine.



**WARNING:** Read the operator's manual to familiarize yourself with the correct control functions.



**WARNING:** Operate the machine and equipment controls from the seat position only. Any other method could result in serious injury.



**WARNING:** This is a one man machine, no riders allowed.



**WARNING:** Before starting engine, study Operator's Manual safety messages. Read all safety signs on machine. Clear the area of other persons. Learn and practice safe use of controls before operating.

It is your responsibility to understand and follow manufacturers instructions on machine operation, service and to observe pertinent laws and regulations. Operator's and Service Manuals may be obtained from your Case dealer.



**WARNING:** If you wear clothing that is too loose or do not use the correct safety equipment for your job, you can be injured. Always wear clothing that will not catch on objects. Extra safety equipment that can be required includes hard hat, safety shoes, ear protection, eye or face protection, heavy gloves and reflector clothing.



**WARNING:** When working in the area of the fan belt with the engine running, avoid loose clothing if possible, and use extreme caution.



**WARNING:** When doing checks and tests on the equipment hydraulics, follow the procedures as they are written. DO NOT change the procedure.



**WARNING:** When putting the hydraulic cylinders on this machine through the necessary cycles to check operation or to remove air from a circuit, make sure all people are out of the way.

# GENERAL INFORMATION



WARNING: Use insulated gloves or mittens when working with hot parts.



WARNING: Lower all attachments to the ground or use stands to safely support the attachments before you do any maintenance or service.



WARNING: Pin sized and smaller streams of hydraulic oil under pressure can penetrate the skin and result in serious infection. If hydraulic oil under pressure does penetrate the skin, seek medical treatment immediately. Maintain all hoses and tubes in good condition. Make sure all connections are tight. Make a replacement of any tube or hose that is damaged or thought to be damaged. DO NOT use your hand to check for leaks, use a piece of cardboard or wood.



WARNING: When removing hardened pins such as a pivot pin, or a hardened shaft, use a soft head (brass or bronze) hammer or use a driver made from brass or bronze and a steel head hammer.



WARNING: When using a hammer to remove and install pivot pins or separate parts using compressed air or using a grinder, wear eye protection that completely encloses the eyes (approved goggles or other approved eye protectors).



WARNING: Use suitable floor (service) jacks or chain hoist to raise wheels or tracks off the floor. Always block machine in place with suitable safety stands.



WARNING: When servicing or repairing the machine, keep the shop floor and operator's compartment and steps free of oil, water, grease, tools, etc. Use an oil absorbing material and/or shop cloths as required. Use safe practices at all times.



WARNING: Some components of this machine are very heavy. Use suitable lifting equipment or additional help as instructed in this Service Manual.



WARNING: Engine exhaust fumes can cause death. If it is necessary to start the engine in a closed place, remove the exhaust fumes from the area with an exhaust pipe extension. Open the doors and get outside air into the area.



WARNING: When the battery electrolyte is frozen, the battery can explode if (1), you try to charge the battery, or (2), you try to jump start and run the engine. To prevent the battery electrolyte from freezing, try to keep the battery at full charge. If you do not follow these instructions, you or others in the area can be injured.

# GENERAL INFORMATION

## STANDARD TORQUE DATA FOR CAP SCREWS AND NUTS

### Tightening of cap screws, nuts

Tighten alternately so that tightening torque can be applied evenly. The numbers in the figure below indicate the order of tightening.

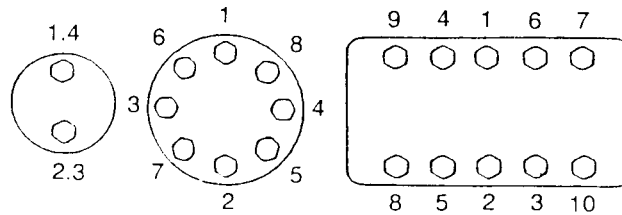

JS00481A

Cap screws which have had Loctite used (white residue remains after removal) should be cleaned with light oil or suitable cleaning solvent and dried. Apply 2-3 drops of Loctite to the thread portion of the cap screw and then tighten.

### Torque table

Tighten cap screws and nuts according to the table below if there are no other special instructions.

Cap Screw Name Size (Size)			M6	M8	M10	M12	M14	M16	M18	M20
Cap Screw	Spanner	[mm]	10	13	17	19	22	24	27	30
		[in.]	0.39	0.51	0.67	0.75	0.87	0.95	1.06	1.18
	Tightening torque	[Nm]	6.9	19.6	39.2	58.8	98.1	157.2	196.0	274.0
		[lb-ft]	5.1	14.5	29.0	43.4	72.5	116.0	144.6	202.4
Socket Head Cap Screw	Spanner	[mm]	5	6	8	10	12	14	14	17
		[in.]	0.20	0.24	0.32	0.39	0.47	0.55	0.55	0.67
	Tightening torque	[Nm]	8.8	21.6	42.1	78.4	117.6	176.4	245.0	343.0
		[lb-ft]	6.5	15.9	31.1	57.8	86.8	130.1	180.8	253.1



# GENERAL INFORMATION

## TYPE, SERIAL NUMBER AND YEAR OF MANUFACTURE OF THE MACHINE

When placing a parts order or making a request for information or assistance, always give you CASE Dealer the type and serial number of the machine concerned.

Enter the required information on the lines below: Type, serial number, year of manufacture of the machine and the serial numbers of hydraulic and mechanical components.

### Machine

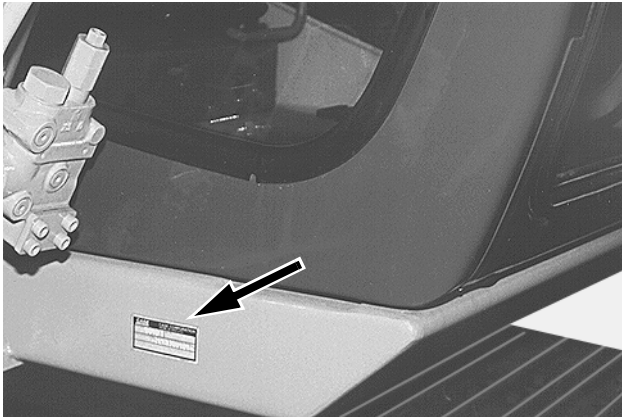

CP98N006

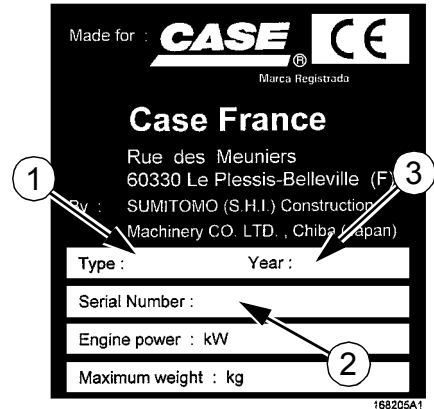

168205A1

CS99A668

(1) Type .....

(2) Serial number .....

(3) Year of manufacture .....

### Engine

Make and type

Serial number

### Component serial numbers

Hydraulic pump

Swing reduction gear

Travel reduction gears

Travel control valve

Attachment control valve

Swing control valve

# GENERAL INFORMATION

## FLUIDS AND LUBRICANTS

Lubricants must have the correct properties for each application.



**WARNING:** The conditions of use for individual fluids and lubricants must be respected.

### Hydraulic fluid

CASE hydraulic fluid is specially designed for high pressure applications and for the CASE hydraulic system. The type of fluid to be used depends on the ambient temperature.

#### Temperate climates

-20°C to +40°C

Fluid type ISO VG 46

CASE reference: POHYDR

#### Hot climates

0°C to +60°C

Fluid type ISO VG 100

CASE reference: POHYPC

#### Cold climates

-40°C to +20°C

Fluid type ISO VG 22

CASE reference: POHYPF

These various grades of fluid must be in conformity with the CASE specification.

### Transmission component oil

Extreme pressure oil used for transmission components inside sealed housings.

Extreme pressure oil TYPE API GL5 GRADE 80W90 or ISO VG 150.

### Grease

The type of grease to use depends on ambient temperature.

#### Temperate and hot climates

-20°C to +60°C

Extreme pressure grease EP NLGI grade 2 with molybdenum disulphide.

#### Cold climates

-40°C to +20°C

Extreme pressure grease EP NLGI grade 0.

### Engine oil

CASE engine oil No. 1 is recommended for your engine. This oil ensures correct lubrication of your engine in all working conditions.

If CASE No. 1 Multiperformance or Performance engine oil is not available, use oil corresponding to category API/CG/CF.

Do not put any Performance Additive or other additive in the sump. Oil change intervals shown in this manual are based on tests carried out on CASE lubricants.

# GENERAL INFORMATION



RD97F136



RD97F100

## Oil viscosity/Oil range

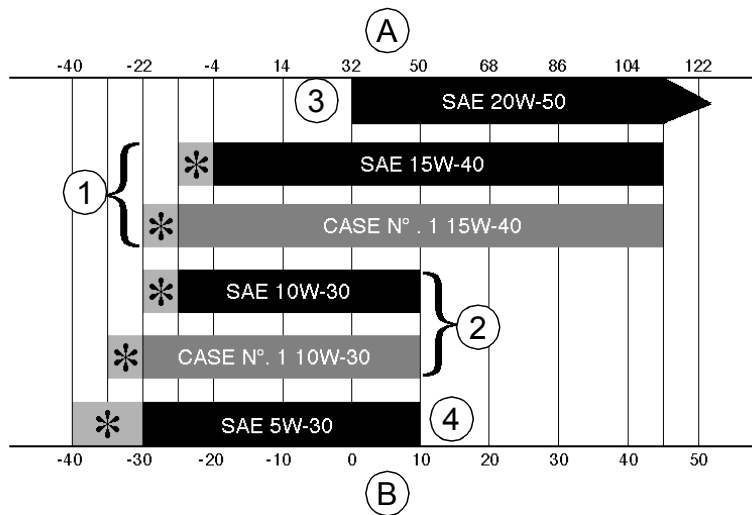

CS98M561

(A) FAHRENHEIT temperature

(B) CELSIUS temperature

(1) all-seasons

(2) winter

(3) tropical

(4) Arctic

(\*) shows that an engine oil heater or engine coolant solution heater must be used.

# GENERAL INFORMATION

## Fuel

Use fuel that is to ASTM (American Society for Testing and Materials) D975 standard.

Use Grade No. 2 fuel. The use of other types of fuel can result in a loss of power and may cause high fuel consumption.

In cold weather, the use of a mixture of fuels No. 1 and

No. 2 is temporarily permitted. Consult your fuel supplier.

If the temperature falls below the fuel cloud point (point at which wax begins to form) the wax crystals will cause power loss or will prevent the engine from starting.

**IMPORTANT : In cold weather, fill the fuel tank at the end of the day's work, in order to prevent the formation of condensation.**

## Fuel storage

Long storage can lead to the accumulation of impurities and condensation in the fuel. Engine trouble can often be traced to the presence of water in the fuel.

The storage tank must be placed outside and the temperature of the fuel should be kept as low as possible. Drain off water and impurities regularly.

## Anti-freeze/Anti-corrosion

Use anti-freeze in all seasons to protect the cooling system from corrosion and all risk of freezing.

In environments with a temperature higher than -36°C, use a mixture of 50% ethylene-glycol based anti-freeze.

For areas where the temperature is below -36°C, it is advisable to use a blend of 40% water and 60% anti-freeze.

## Environment

Before carrying out any servicing operation on this machine and before disposing of used fluids or lubricants, always think of the environment. Never throw fluid or oil on the ground and never keep them in lea-

king receptacles.

Consult your local ecological recycling centre to obtain information on the appropriate means of disposing of these substances.

## Components made from plastic or resin

When cleaning plastic parts, the console, the instrument panel, the gauges, etc., do not use petrol (gasoline), paraffin (kerosene), paint solvents, etc. Use only water, soap and a soft cloth.

The use of petrol (gasoline), paraffin (kerosene), paint solvents, etc, will cause discoloration, cracking or deformation of these components.

# GENERAL INFORMATION

## Engine . . . . . CX130

Make	Isuzu
Model	BB-4BG1T
Type:	Four stroke, water-cooled, overhead valve, direct injection electronically controlled), in-line engine with turbo-charger.
Number of cylinders	4
Bore and stroke	105x125 mm
Cubic capacity	4329 cm <sup>3</sup>

## Operating conditions

Speed	2100 rpm
ECC 1289 power rating	69.1 kW (94 hp)
Couple maxi	324 Nm at 1600 rpm

## Capacities

Engine oil capacity	15 litres
Engine cooling system	17.7 litres
Fuel tank	250 litres
Hydraulic fluid reservoir capacity	73 litres
Total hydraulic system capacity	123 litres
Travel reduction gear housing capacity	3 litres
Swing drive housing capacity	2.2 litres

NOTE: These capacities are only provided in an indicative manner. To check fluid levels, always use the oil dipstick, sight glasses or the filler cap.

## Electrical system

Type of system	24 volts negative earth
Alternator amperage	40 amps
Battery	
Number of batteries required	2
Voltage of each battery	12 volts
Capacity	120 Ah
Starter motor	
Voltage	24 volts
Power	4.5 kW

## Hydraulic system

Hydraulic pump	CX130
Double, axial piston, variable flow pump	
Maximum pump flow	2x123 l/min
Fixed flow pump (pilot system)	
Maximum pilot pump flow	23 l/min
Working pressure	
Standard	343 ±3 bar
Higher pressure (2-stage relief)	363 ±5 bar

# GENERAL INFORMATION

## Cylinder

	Boom cylinder	Dipper cylinder	Bucket cylinder
	CX130	CX130	CX130
<b>Barrel diameter</b>	105 mm	115 mm	95 mm
<b>Rod diameter</b>	70 mm	80 mm	65 mm
<b>Stroke</b>	990 mm	1110 mm	880 mm

## Control valve

Five section control valve for dipper, boom acceleration, swing, option and RH travel.

Four section control valve for dipper acceleration, bucket, boom and LH travel.

Load holding valve for boom and dipper.

## Swing

Fixed flow, axial piston motor.

Automatic disc brake.

upperstructure swing speed - - - - - 13.4 rpm

## Travel

Two-speed, axial piston motor.

Automatic disc brake.

First speed - - - - - 3.8 kph

Second speed - - - - - 5.5 kph

Gradeability - - - - - 70% (35°)

Tractive force - - - - - 10 000 daN

## Attachment

Break-out force (standard/higher pressure (2-stage relief)) - - - - - /8640 daN

Crowd force (standard/higher pressure (2-stage relief)) - - - - - /6560 daN

## Undercarriage

One-piece undercarriage with welded components.

Lubricated rollers and idler wheels.

Grease type track tension.

Ground pressure

with 500 mm track pads - - - - - 0.39 bar

with 600 mm track pads - - - - - 0.33 bar

with 700 mm track pads - - - - - 0.29 bar

## Weight

Engine 361 kg

Hydraulic pump 90 kg

Attachment control valve 140 kg

Motor/reduction gear assembly 99 kg

travel motor/reduction gear assembly 144 kg

Boom cylinder 108 kg

Dipper cylinder 157 kg

Bucket cylinder 93 kg

# GENERAL INFORMATION

## SPECIAL TORQUE SETTINGS

N	Component	Screw (Ø)	Key (mm)	Torque setting (Nm)	
				CX130	CX210
1 *	Travel motor/reduction gear assembly	M16	24	267-312	267-312
2 *	Sprocket	M16	24	267-312	267-312
3 *	Idler wheel	M16	24	267-312	267-312
4 *	Upper roller	M16	24	267-312	-
		M20	30	-	521-608
5 *	Lower roller	M16	27	267-312	-
		M18	27	-	371-432
6	Chain guide	M18	27	-	380-443
7	Track pad	M16	24	392-430	-
		M20	30	-	300 + 120°
8	Counterweight	M27	41	844-980	-
		M27	41	-	1058-1235
		M30	46	-	1333-1549
9	Turntable (undercarriage)	M16	24	280-322	-
		M20	30	-	468-545
		M24	36	-	783-913
10	Turntable (upperstructure)	M16	24	280-322	-
		M20	30	-	468-545
		M24	36	-	783-913
11 *	Swing motor/reduction gear assembly	M16	24	280-322	-
		M20	30	-	521-608
		M24	36	-	783-913
12 *	Engine	M16	24	265-313	265-313
13 *	Engine support	M10	17	64-73	64-74
14	Radiator	M12	19	64-73	-
		M16	24	-	147-176
15 *	Hydraulic pump	M10	17	63-72	-
		M10	17	-	64-74
		M20		-	367-496
16 *	Hydraulic reservoir	M16	24	206-247	-
		M16	24	-	232-276
17 *	Fuel tank	M16	24	206-247	-
		M16	24	-	232-276
18 *	Control valve	M16	24	267-312	267-312
		M12	19	88-107	-
19 *	Hydraulic swivel	M12	19	109-127	109-127
20	Cab	M16	24	78-80	78-80
21	Battery	M10	17	20-29	20-29

**Nota:** Use Loctite 262 or an equivalent on retaining screws of components marked with an asterisk (\*).

# GENERAL INFORMATION

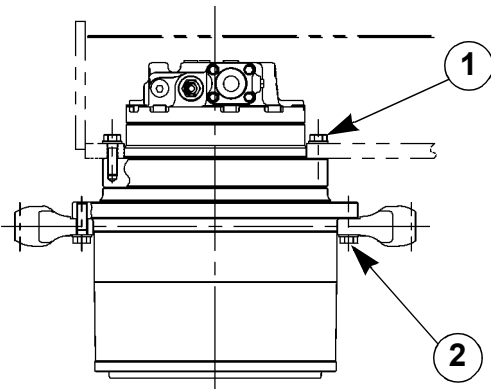
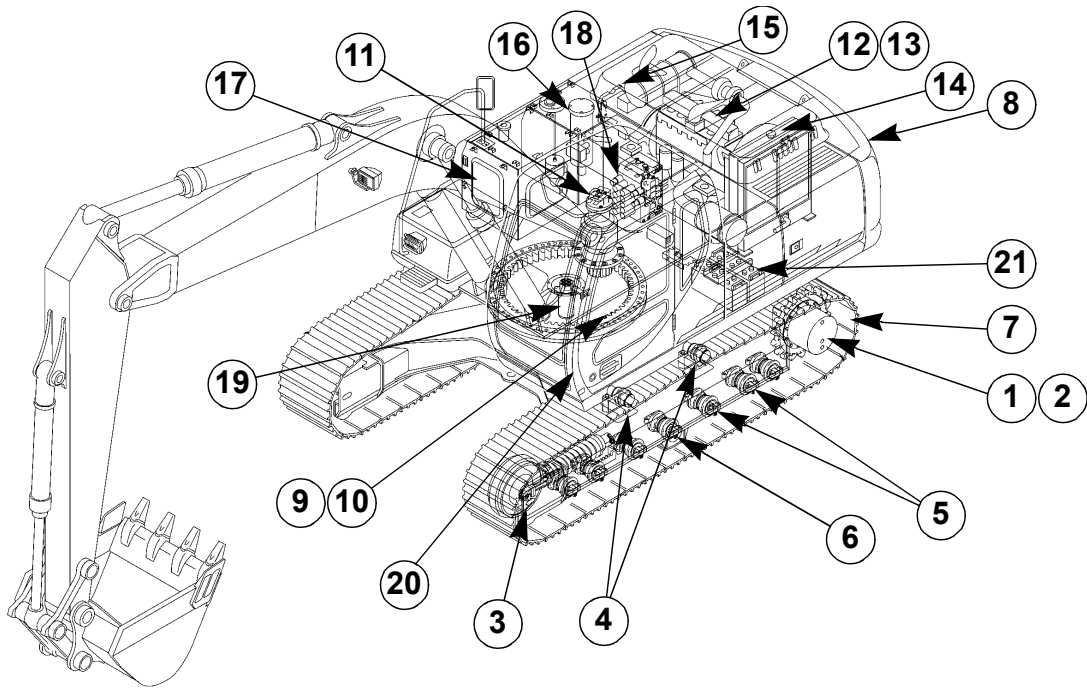

CS00E508

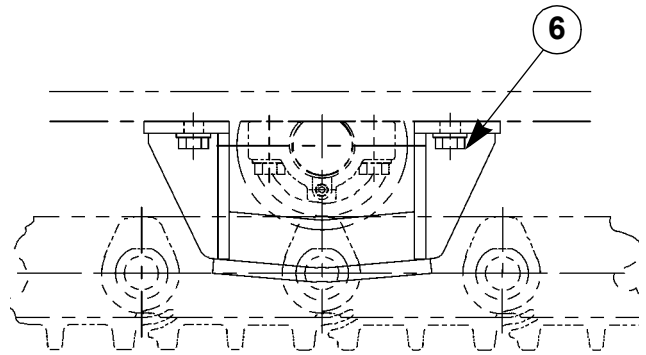

CS00E509

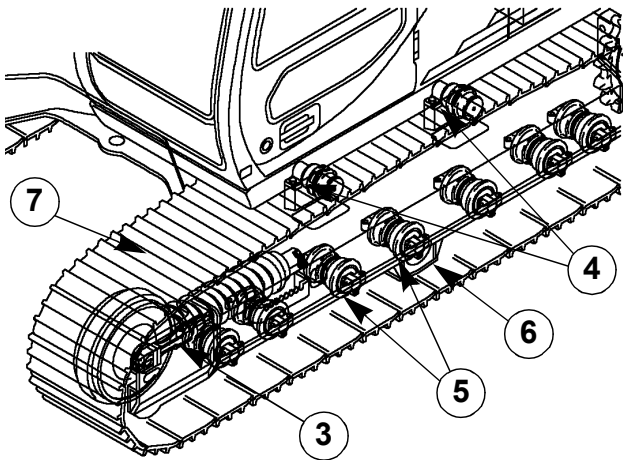

CS00E510

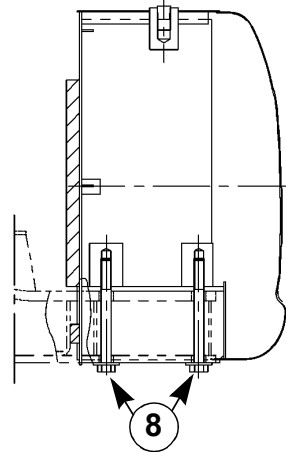



# GENERAL INFORMATION

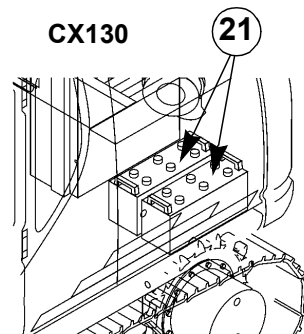
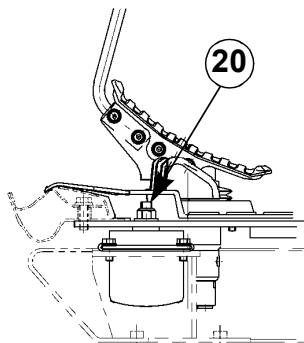
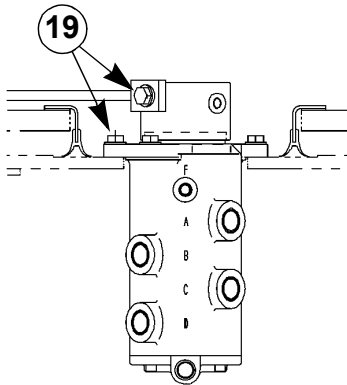
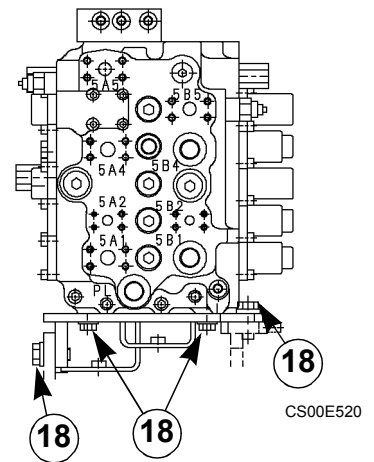
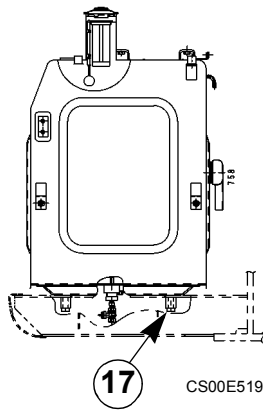
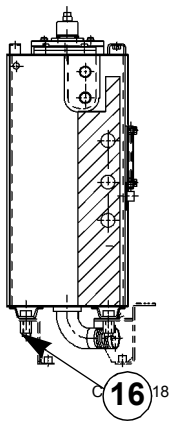
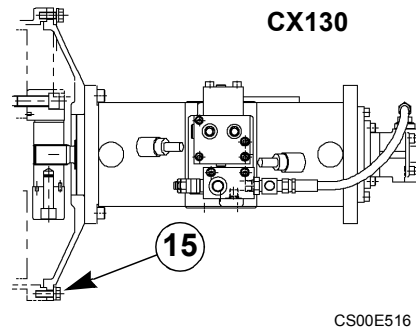
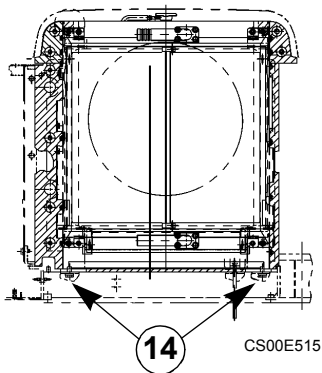
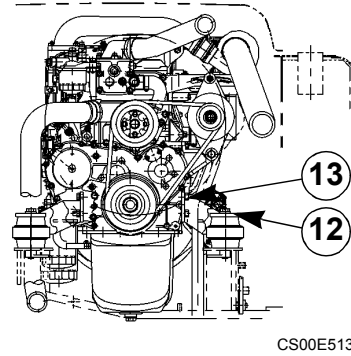
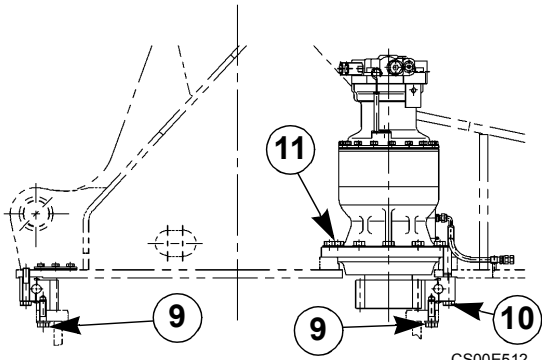

# GENERAL INFORMATION

## MACHINE OVERALL DIMENSIONS

Only on CX130 machines with 3 m dipper

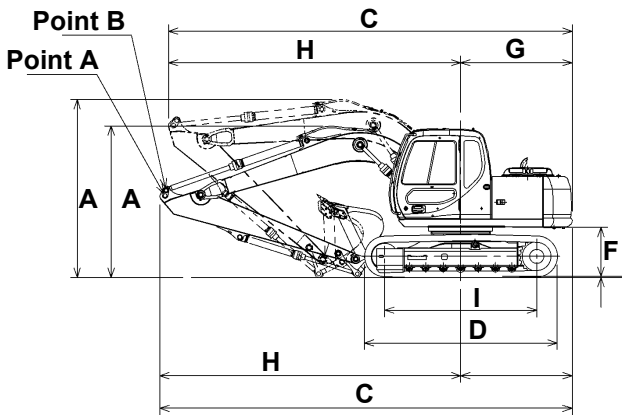

CS00E527

Point A: Working position  
Point B: Transport position

**IMPORTANT:** For CX130 machines with 3 m dipper, it is imperative that the dipper cylinder head/dipper linkage is positioned at point B.

**NOTE:** Never work with the pin in this position.



**WARNING:** When the dipper cylinder is placed in position B (transport), take care not to damage the cab, there can be interference between the bucket and the cab.

	CX130			
	Dipper			
	2.10 m	2.50 m	3.00 m (A)	3.00 m (B)
A	2.74 m	2.74 m	3.26 m	2.78 m
B	2.74 m	2.74 m	2.74 m	2.74 m
C	7.48 m	7.49 m	7.38 m	7.54 m
D	3.54 m	3.54 m	3.54 m	3.54 m
E	2.52 m	2.52 m	2.52 m	2.52 m
F	0.894 m	0.894 m	0.894 m	0.894 m
G	2.04 m	2.04 m	2.04 m	2.04 m
H	5.44 m	5.45 m	5.34 m	5.50 m
I	2.78 m	2.78 m	2.78 m	2.78 m
J	1.99 m	1.99 m	1.99 m	1.99 m
K	0.50 m	0.50 m	0.50 m	0.50 m
L (with 500 mm track pads)	2.49 m	2.49 m	2.49 m	2.49 m
L (with 600 mm track pads)	2.59 m	2.59 m	2.59 m	2.59 m
L (with 700 mm track pads)	2.69 m	2.69 m	2.69 m	2.69 m
M	0.46 m	0.46 m	0.46 m	0.46 m

# GENERAL INFORMATION

## FLUIDS AND LUBRICANTS

Lubricants must have the correct properties for each application.



**WARNING:** *The conditions of use for individual fluids and lubricants must be respected.*

### Hydraulic fluid

CASE hydraulic fluid is specially designed for high pressure applications and for the CASE hydraulic system. The type of fluid to be used depends on the ambient temperature.

#### Temperate climates

-20°C to +40°C  
Fluid type ISO VG 46

#### Hot climates

0°C to +60°C  
Fluid type ISO VG 100

#### Cold climates

-40°C to +20°C  
Fluid type ISO VG 22

These various grades of fluid must be in conformity with CASE.

### Transmission component oil

Extreme pressure oil used for enclosed transmission components.  
Extreme pressure oil type API GL5 grade 80W90 or ISO VG 150

### Grease

The type of grease to use depends on ambient temperature.

#### Temperate and hot climates

-20°C to +60°C  
Extreme pressure grease EP NLGI grade 2 with molybdenum disulphide.

#### Cold climates

-40°C to +20°C  
Extreme pressure grease EP NLGI grade 0.

## GENERAL INFORMATION

### Engine oil

CASE N°1 motor oil is the oil recommended for your engine. This oil ensures correct lubrication of your engine in all working conditions.

If CASE N°1 Multiperformance or Performance engine oil cannot be obtained, use only oil of the API/CG/CF category.

**NOTE:** Do not put any Performance Additive or other additive in the sump. Oil change intervals shown in this manual are based on tests carried out on CASE lubricants.



### Oil viscosity/Oil range

