



OPERATOR'S MANUAL

EXCAVATOR

CX80 TIER 3



READ, UNDERSTAND, AND FOLLOW ALL SAFETY PRECAUTIONS AND INSTRUCTIONS FOUND IN THIS MANUAL BEFORE OPERATING THE MACHINE.

Bur • Issued 01 April 08

Printed in U.S.A. • Book/Form Number 87490339 NA

Copyright © 2007. CNH America, LLC. All Rights Reserved.

CNH America, LLC reserves the right to make improvements in design or changes in specifications at any time without incurring any obligation to install them on units previously sold.

All data given in this publication is subject to production variations. Dimensions and weights are only approximate. Illustrations do not necessarily show products in standard condition. For exact information about any particular product, please consult your Dealer

REVISION HISTORY			
Issue	Issue Date	Applicable Machines	Remarks
First Edition	01April 08	CX80 Tier 3 Excavator	87490339 NA







THIS SAFETY ALERT SYMBOL INDICATES IMPORTANT SAFETY MESSAGES IN THIS MANUAL. WHEN YOU SEE THIS SYMBOL, CAREFULLY READ THE MESSAGE THAT FOLLOWS AND BE ALERT TO THE POSSIBILITY OF DEATH OR SERIOUS INJURY.

Safety Decals on this machine use the words Danger, Warning, or Caution, which are defined as follows:

- **DANGER:** Indicates an immediate hazardous situation that, if not avoided, will result in death or serious injury. The color associated with Danger is RED.
- **WARNING:** Indicates a potentially hazardous situation that, if not avoided, could result in death or serious injury. The color associated with Warning is ORANGE.
- **CAUTION:** Indicates a potentially hazardous situation which, if not avoided, may result in minor or moderate injury. It may also be used to alert against unsafe practices. The color associated with Caution is YELLOW.

If Safety Decals on this machine are ISO two panel Pictorial, decals are defined as follows:

- The first panel indicates the nature of the hazard.
- The second panel indicates the appropriate avoidance of the hazard.
- Background color is YELLOW
- Prohibition symbols such as   and  if used, are RED.



WARNING

IMPROPER OPERATION OF THIS MACHINE CAN CAUSE DEATH OR SERIOUS INJURY. BEFORE USING THIS MACHINE, MAKE CERTAIN THAT EVERY OPERATOR:

- ② Is instructed in safe and proper use of the machine.
- ② Reads and understands the Manual(s) pertaining to the machine.
- ② Reads and understands ALL Safety Decals on the machine.
- ② Clears the area of other persons.
- ② Learns and practices safe use of machine controls in a safe, clear area before operating this machine on a job site.

It is your responsibility to observe pertinent laws and regulations and follow instructions on machine operation and maintenance.

CALIFORNIA PROPOSITION 65 WARNING

Diesel engine exhaust and some of its constituents are known to the State of California to cause cancer, birth defects, and other reproductive harm.

Battery post, terminals and related accessories contain lead and lead compounds. Wash hands after handling.

TECHNICAL MANUALS

Manuals are available from your Dealer for the operation, service, and repair of your machine. Contact your Dealer for assistance in obtaining the manuals for your machine. Your Dealer can expedite your order for Operator's Manuals, Parts Catalogs, Service Manuals, and maintenance records. Always give the Machine Name, Model, and P. I.N. (Product Identification Number) or S. N. (Serial Number) of your machine so your Dealer can provide the correct manuals for your machine.

To the Owner

Your machine has been designed and built to the highest standards of quality. It conforms to all current safety regulations. See "Official documents". However, the risk of accidents can never be completely excluded. That is why it is essential to observe elementary safety rules and precautions.

Read this manual carefully, paying particular attention to the instructions concerning safety, operation and maintenance so as to avoid the risk of injury while operating or servicing the machine.

Use this manual as a guide. Your machine will remain a reliable working tool provided it is kept in good working condition and serviced properly.

The standard attachments and equipment available for use with this machine are intended for general earth-moving purposes, material rehandling, boring, ditch cleaning, etc. If the machine is to be used for handling loads, (concrete pipe sections, shoring material, etc.), make sure the machine is suitably equipped for this type of work. For this type of application, the machine must be equipped with safety valves, an overload indicator, a load handling chart corresponding to the type of machine and its attachment and a load fixing point. All legal requirements must also be strictly observed.

Do not use this machine for any application or purpose other than those described in this manual. If the machine is to be used for work involving the use of special attachments, accessories or equipment, consult your CASE Dealer in order to make sure that any adaptations or modifications made are in keeping with the machine's technical specifications and with prevailing safety requirements.

Any modification or adaptation which is not approved by the manufacturer may invalidate the machine's initial conformity with safety requirements.

The machine must undergo regular inspections, the frequency of which varies according to the type of use. Consult your CASE Dealer.

Before permitting a new operator on this machine, make sure:

1. That the operator has received the necessary training on how to operate the machine correctly and safely in one of our training centers or from an approved organization.
2. That the operator has read and understood the instructions given in this manual.

Always keep this manual in the operator's compartment (in the seat back, behind the operator's seat). Make sure it is always complete and in good condition. If you wish to obtain additional manuals, or manuals in another language, consult your CASE Dealer.

Your CASE Dealer is at your disposal for any further information. He will also provide any after-sales service you may require, and genuine CASE spare parts, your guarantee of quality and match.

Safety Labels

RIGHT, LEFT, FRONT AND REAR OF THE MACHINE

The terms “Right”, “Left”, “Front” and “Rear” are used in this manual to indicate the sides as they are seen from the operator’s seat when the cab is over the idler wheels.

The illustration below shows the machine in normal TRAVEL position. In normal TRAVEL position, the cab is over the idler wheels. The travel reduction gears are at the rear of the upperstructure.

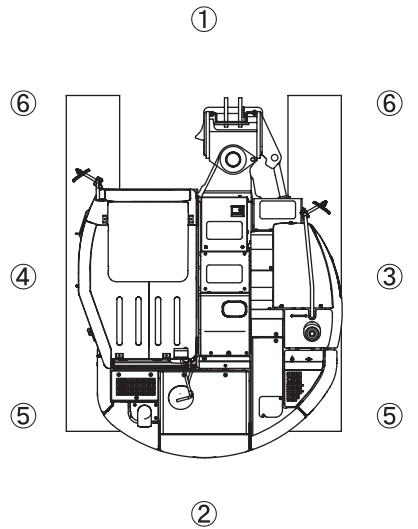

0-0178E

- | | |
|-------------------|--------------------------|
| ① FRONT | ④ LEFT-HAND SIDE |
| ② REAR | ⑤ TRAVEL REDUCTION GEARS |
| ③ RIGHT-HAND SIDE | ⑥ IDLER WHEELS |

Break-in

This product is shipped after full inspections and conditioning, however, extremely overloaded usage at the initial stage could lead the reduction in performance and life. Therefore, approx. initial 100 hours (indicated hours on the service meter) break-in is necessary.

Break-in should be conducted paying attention to the following points:

- Try to keep idling and warming for 5 minutes after starting the engine.
- Avoid operation under heavy load or at high speeds.
- Avoid any sudden start, acceleration or unnecessary sudden stop and quick turn.

Specified Work

This product is designed to use mainly in the following work:

- Excavation
- Land grading work
- Trenching work
- Loading work
- Demolition (Demolition specification vehicle only)

For Safe Driving

IMPORTANT:

Remove the protective (rust preventative) aluminum cover wrapped around the cylinder rods immediately after receiving the machine. If the machine is left with the covers on, water can collect on the inside of the cover, which will be the cause for rust to develop on the cylinder rod.

In the case of transportation by sea, sea water salt adheres to the machine making rust easier to develop. Immediately follow the measures below after receiving a machine that has been transported by sea. If the measures are not taken, the machine will develop rust easily.

1. Confirm that there are no salt deposits on the machine exterior. When salt deposits are suspected, wash the entire machine with water.

⚠ CAUTION

Do not use high pressure cleaning water directly on the alternator, battery and other electrical parts or wiring.

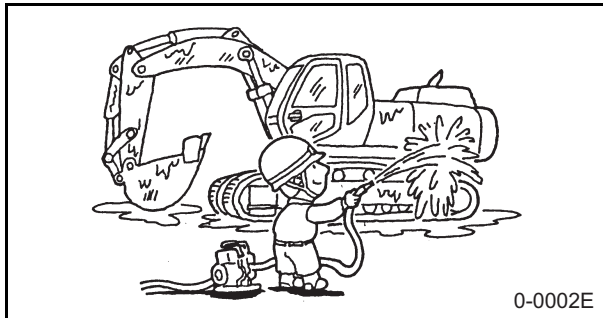

2. Performing Rust Prevention Operation.

⚠ CAUTION

Start the engine after you understand the operation methods.

- ① Set the engine at low~medium rpm and go through the warming up operation.
- ② Slowly operate each cylinder of the front attachment five strokes each.

3. If Storage Is To Be Continued
[Storage procedures for rust prevention.]

- ① Grease up each part of the attachment.

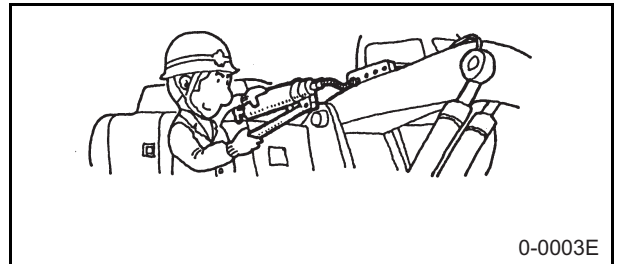

Storage for up to one month

- (1) Once a week operate each motion (attachment, swing, travel) with no load which performs rust prevention operation.
- ① Put the engine in low~medium rpm and perform the warming up operation.
- ② Slowly operate each cylinder of the front attachment five strokes each.

Storage for more than one month

- (1) Place each cylinder in the most retracted position and apply anti-rust oil to the exposed cylinder rod.

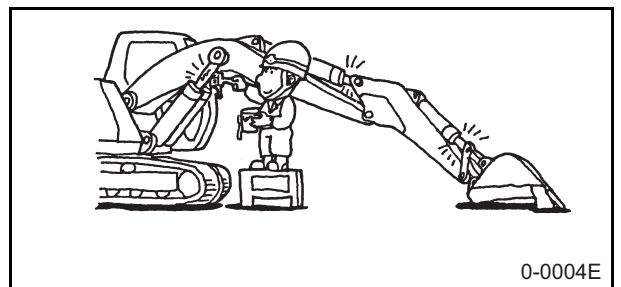

- (2) Perform rust-prevention operation once a month.
- ① Before performing the rust-prevention operation, remove the anti-rust oil (wipe off with kerosene, etc.).
- ② After finishing the rust prevention operation, fully retract each cylinder and apply anti-rust oil to the exposed cylinder rod.

For Safe Driving

SAFETY INSTRUCTIONS

Your safety and that of people around you depend on you. It is essential that you understand this manual for the correct operation, inspection, lubrication and maintenance of this machine.

Read this manual carefully and check that :

- You understand fully the symbols on the controls and the safety signs used in this manual and on the machine.
- You understand fully the speed, stability, braking and steering characteristics of the machine. If you are in any doubt, consult your CASE Dealer.

The safety messages in this manual concern situations which may arise during normal machine operation and servicing. These safety messages also indicate the different ways of coping with these situations. Other safety messages are used throughout the manual to indicate specific dangers.

Whatever type of work is being done (earthmoving, handling, drilling, etc.), the safety measures for private or public work-sites are those which conform to current regulations in the country concerned, or the type of operation concerned (mining, quarrying, tunnelling).

The safety instructions given in this manual are a summary of the basic rules to be respected at all times and do not exempt you from insurance requirements or from abiding by the highway code. Always keep this manual in the storage compartment "Pocket" provided for it. Make sure it is always complete and in good condition.

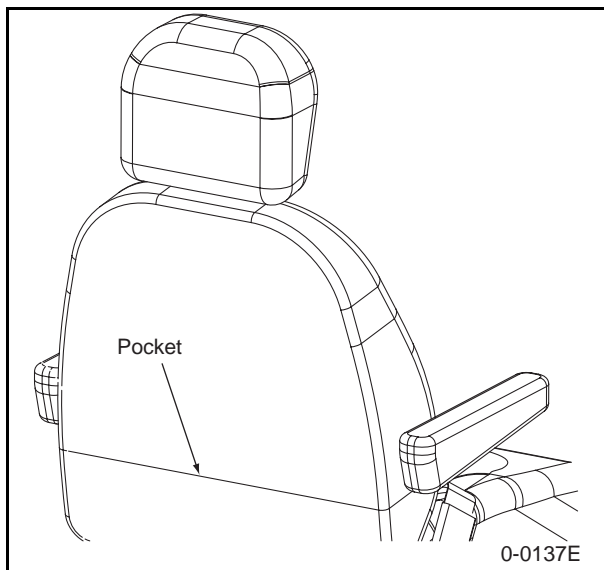

For Safe Driving

Warranty

In case faults occur to the machine, the warranty is valid within the range described in the warranty document.

Model and Serial number of manufacture

When ordering parts, obtaining information or assistance, always supply your CASE dealer with the type and serial number of your machine or accessories.

Write the following in the spaces below: The model number, serial number and year of manufacture of your machine, accessories and the serial number of the various hydraulic and mechanical components.

Machine

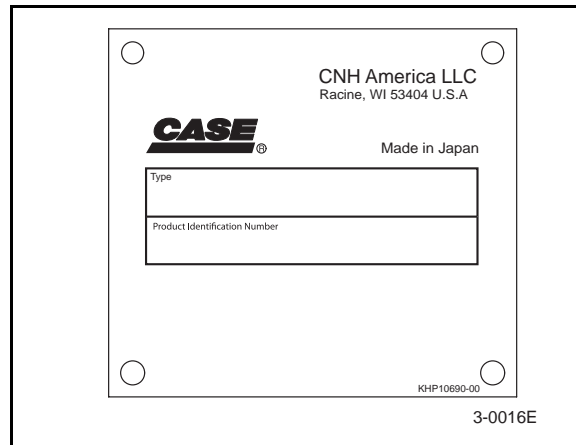
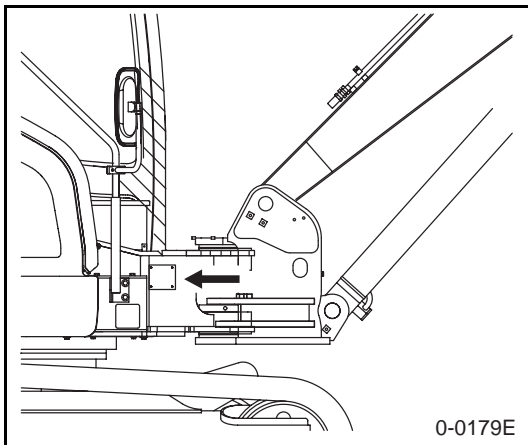

Excavator Identification _____

Model Number _____

Serial Number _____

Engine

Make and type _____

Serial number _____

Component serial numbers

Hydraulic pump _____

Swing reduction gear _____

Travel reduction gears _____

Travel control valve _____

Attachment control valve _____

Swing control valve _____

Table of Contents

To the Owner	0-1
Safety Labels	0-2
For Safe Driving	0-3

Safety Section

Safety Section	0-7
Precaution Identification Plates (DECALS)	0-8
Identification Plates inside the Cabin	0-8
Outside Identification Plate	0-13
Precaution Identification Plates on Parts (Examples)	0-17
Prior to Operation	0-18
Confirmation of Safety items	0-20
During Operation	0-23
While Traveling	0-27
After Operating	0-28
While Transporting	0-29
Before Regular Inspection & Maintenance	0-30
Inspection and Maintenance	0-31

Instruments and Controls

Instruments and Controls	1-0
Location of Components	1-1
Overall View	1-1
Operator's Cab	1-2
Right Console	1-4
Right Console	1-4
Monitor & Switch Panel	1-5
Monitor & Switch Panel	1-5
Monitor Display	1-6
Switch Panel	1-7
Left Console	1-9
Left Console	1-9
Switch	1-10
Air Conditioner	1-11
Air Conditioner (If equipped)	1-11
Explanation of device	1-13
Radio	1-13
Operation Levers	1-15
Operation Levers	1-15
Operator's Seat	1-19
Operator's Seat	1-19
Operator's Cab	1-21
Fuses	1-23
Fuses	1-23
Explanation of device	1-24
Battery	1-24
Starting the Engine by Using Booster Cables	1-25

Operating Instructions

Operating Instructions	2-0
Operation of New Machine	2-1
Using a New Machine	2-1
Daily Inspections	2-2
Daily Inspections	2-2
Starting and Stopping the Engine	2-4
Inspections before Starting the Engine	2-4
Starting the Engine	2-5
Inspections after Starting the Engine	2-6
Stopping the Engine (Normal Operation)	2-7
Warm-up Operation	2-8

Warm-up Operation	2-8
Operations (Traveling)	2-10
Operations (Swing)	2-19
Swing Operation	2-19
Operations (Attachment)	2-20
Operations (Attachment)	2-20
Operations	2-21
Blade Operation	2-22
Characteristics of Hydraulic Excavator	2-22
Cautions for operations	2-23
Cautions for Interference	2-23
Operating Instructions (Cautions)	2-25
Operating Instructions (Procedures)	2-26
Bucket: Turning Over and Replacement	2-28
Bucket: Turning Over and Replacement	2-28
On Completion of Daily Operations	2-30
On Completion of Daily Operations	2-30
Operating in Cold Climates	2-32
Operating under Extreme Conditions	2-33
Transportation	2-34
Loading and Unloading	2-34
Switch settings during loading and unloading	2-34
Transportation	2-34
Storing	2-38

Inspections and Maintenance

Inspections and Maintenance	3-0
General Cautions	3-1
Periodic Maintenance Check List	3-2
Daily Inspections (Prior to Operation)	3-2
Periodic Maintenance Check List	3-3
Fuel / Lubricants for Different Ambient Temperature Settings	3-4
Genuine CASE Company LLC Parts and Elements	3-5
Disposable Items	3-6
Grease / Oil and Elements	3-7
Inspection Prior to Operation	3-8
Inspections Prior to Operation	3-8
Greasing Attachments	3-12
Greasing Front Attachment Pins	3-12
Fuel System	3-15
Fuel	3-15
Fuel Refilling and Fuel Level Checking	3-18
Drainage of Water and Sediments in the Fuel Tank	3-18
.....	3-18
Draining Water from the Water Separator	3-19
Fuel Filter (Main) Replacement	3-19
Engine	3-20
Engine Oil Replacement	3-20
Engine Oil Filter Replacement	3-20
Cooling System	3-22
Inspecting and Refilling Coolant	3-22
Replacing the Coolant	3-23
Cleaning and Inspecting the Radiator Net and Fin	3-24
.....	3-24
Cleaning and Replacing the Air Cleaner (double elements)	3-25
Inspection and Adjustment of Fan Belt	3-27
Bolt Torque	3-28
Bolt and Nut Torque	3-28

Table of Contents

Hydraulic Oil.....	3-31	Using the Crusher (Attachment)	5-7
Hydraulic Oil Level Inspection.....	3-31	Load Lifting Operation.....	5-10
Refilling Hydraulic Oil.....	3-31		
Draining Water and Sediment from the Hydraulic Oil Tank	3-32		
Hydraulic Oil Management.....	3-33		
Hydraulic Oil Replacement.....	3-33		
Bleeding Air from the Hydraulic Components	3-34		
Air Bleeding Procedures	3-34		
Air Bleeding from Hydraulic Pump	3-34		
Air Bleeding from Cylinder	3-35		
Air Bleeding from Swing Motor.....	3-35		
Cleaning and Replacing Suction Filter	3-36		
Replacing Return Filter	3-36		
Replacing Air Breather Element.....	3-37		
Replacing Pilot Oil Filter Element.....	3-37		
Replacement Intervals for Hydraulic Oil and Filters when Using Breaker.....	3-38		
Checking Hoses and Lines	3-38		
Battery.....	3-39		
Battery Inspection and Charge.....	3-39		
Upper Frame	3-41		
Turntable Bearing Greasing	3-41		
Greasing Swing Ring Gear	3-41		
Travel Unit.....	3-42		
Travel Reduction Gear	3-42		
Oil Level Inspection and Refilling of Travel Reduction Gear	3-42		
Oil Replacement for Travel Reduction Gear	3-42		
Inspecting Upper/Lower Take-up Roller (Idler Wheel)	3-43		
Inspection and Tightening of Shoe Plate	3-43		
Cleaning Crawler.....	3-43		
Inspection and Adjustment of Track Shoe Tension	3-44		
Bucket.....	3-45		
Replacing Bucket Teeth: Standard type (Length Pin Type).....	3-45		
Adjustment of Bucket Backlash.....	3-47		
Air Conditioner	3-48		
Inspection and Care of Air Conditioner (If Equipped)	3-48		
Routine Replacement Safety Parts.....	3-52		
Troubleshooting	3-53		
Contacting Us	3-58		
Specifications.....	4-0		
Conversion Factors.....	4-1		
CONVERSION FACTORS.....	4-1		
Specifications.....	4-2		
CX80	4-2		
Optional Components.....	5-0		
Breakers.....	5-1		
Handling the Breaker (Attachment).....	5-1		
When Using a Hydraulic Breaker	5-2		
Operating the breaker	5-4		
Importance of Hydraulic oil Control	5-5		
Crusher	5-7		

Case Crawler Excavator Cx80 Operators Manual

Full download: <http://manualplace.com/download/case-crawler-excavator-cx80-operators-manual/>