



OPERATOR'S MANUAL

EXCAVATOR

CX350B TIER 3



READ, UNDERSTAND, AND FOLLOW ALL SAFETY PRECAUTIONS AND INSTRUCTIONS FOUND IN THIS MANUAL BEFORE OPERATING THE MACHINE.

Bur • Issued 01May 08

Printed in U.S.A. • Book/Form Number 87493801 NA

Copyright © 2008. CNH America, LLC. All Rights Reserved.

CNH America, LLC reserves the right to make improvements in design or changes in specifications at any time without incurring any obligation to install them on units previously sold.

All data given in this publication is subject to production variations. Dimensions and weights are only approximate. Illustrations do not necessarily show products in standard condition. For exact information about any particular product, please consult your Dealer

| This unit first became available 05-2008 | | | |
|--|------------|-------------------------|-------------|
| REVISION HISTORY | | | |
| Issue | Issue Date | Applicable Machines | Remarks |
| First Edition | 01May 08 | CX350B Tier 3 Excavator | 87493801 NA |



THIS SAFETY ALERT SYMBOL INDICATES IMPORTANT SAFETY MESSAGES IN THIS MANUAL. WHEN YOU SEE THIS SYMBOL, CAREFULLY READ THE MESSAGE THAT FOLLOWS AND BE ALERT TO THE POSSIBILITY OF DEATH OR SERIOUS INJURY.

Safety Decals on this machine use the words Danger, Warning, or Caution, which are defined as follows:



- **DANGER:** Indicates an immediate hazardous situation that, if not avoided, will result in death or serious injury.

The color associated with Danger is RED.

- **WARNING:** Indicates a potentially hazardous situation that, if not avoided, could result in death or serious injury. The color associated with Warning is ORANGE.

- **CAUTION:** Indicates a potentially hazardous situation which, if not avoided, may result in minor or moderate injury. It may also be used to alert against unsafe practices. The color associated with Caution is YELLOW.

If Safety Decals on this machine are ISO two panel Pictorial, decals are defined as follows:

- The first panel indicates the nature of the hazard.
- The second panel indicates the appropriate avoidance of the hazard.
- Background color is YELLOW
- Prohibition symbols such as , , and  if used, are RED.

WARNING

IMPROPER OPERATION OF THIS MACHINE CAN CAUSE DEATH OR SERIOUS INJURY. BEFORE USING THIS MACHINE, MAKE CERTAIN THAT EVERY OPERATOR:

- ② Is instructed in safe and proper use of the machine.
- ② Reads and understands the Manual(s) pertaining to the machine.
- ② Reads and understands ALL Safety Decals on the machine.
- ② Clears the area of other persons.
- ② Learns and practices safe use of machine controls in a safe, clear area before operating this machine on a job site.

It is your responsibility to observe pertinent laws and regulations and follow instructions on machine operation and maintenance.

CALIFORNIA PROPOSITION 65 WARNING

Diesel engine exhaust and some of its constituents are known to the State of California to cause cancer, birth defects, and other reproductive harm.

Battery post, terminals and related accessories contain lead and lead compounds. Wash hands after handling.

TECHNICAL MANUALS

Manuals are available from your Dealer for the operation, service, and repair of your machine.

Contact your Dealer for assistance in obtaining the manuals for your machine. Your Dealer can expedite your order for Operator's Manuals, Parts Catalogs, Service Manuals, and maintenance records.

Always give the Machine Name, Model, and P. I. N. (Product Identification Number) or S. N. (Serial Number) of your machine so your Dealer can provide the correct manuals for your machine.

To the Owner

Your machine has been designed and built to the highest standards of quality. It conforms to all current safety regulations. See "Official documents". However, the risk of accidents can never be completely excluded. That is why it is essential to observe elementary safety rules and precautions.

Read this manual carefully, paying particular attention to the instructions concerning safety, operation and maintenance so as to avoid the risk of injury while operating or servicing the machine.

Use this manual as a guide. Your machine will remain a reliable working tool provided it is kept in good working condition and serviced properly.

The standard attachments and equipment available for use with this machine are intended for general earth-moving purposes, material rehandling, boring, ditch cleaning, etc. If the machine is to be used for handling loads, (concrete pipe sections, shoring material, etc.), make sure the machine is suitably equipped for this type of work. For this type of application, the machine must be equipped with safety valves, an overload indicator, a load handling chart corresponding to the type of machine and its attachment and a load fixing point. All legal requirements must also be strictly observed.

Do not use this machine for any application or purpose other than those described in this manual. If the machine is to be used for work involving the use of special attachments, accessories or equipment, consult your CASE Dealer in order to make sure that any adaptations or modifications made are in keeping with the machine's technical specifications and with prevailing safety requirements.

Any modification or adaptation which is not approved by the manufacturer may invalidate the machine's initial conformity with safety requirements.

The machine must undergo regular inspections, the frequency of which varies according to the type of use. Consult your CASE Dealer.

Before permitting a new operator on this machine, make sure:

1. That the operator has received the necessary training on how to operate the machine correctly and safely in one of our training centers or from an approved organization.
2. That the operator has read and understood the instructions given in this manual.

Always keep this manual in the operator's compartment (in the seat back, behind the operator's seat). Make sure it is always complete and in good condition. If you wish to obtain additional manuals, or manuals in another language, consult your CASE Dealer.

Your CASE Dealer is at your disposal for any further information. He will also provide any after-sales service you may require, and genuine CASE spare parts, your guarantee of quality and match.

Safety Labels

RIGHT, LEFT, FRONT AND REAR OF THE MACHINE

The terms “Right”, “Left”, “Front” and “Rear” are used in this manual to indicate the sides as they are seen from the operator’s seat when the cab is over the idler wheels.

The illustration below shows the machine in normal TRAVEL position. In normal TRAVEL position, the cab is over the idler wheels. The travel reduction gears are at the rear of the upperstructure.

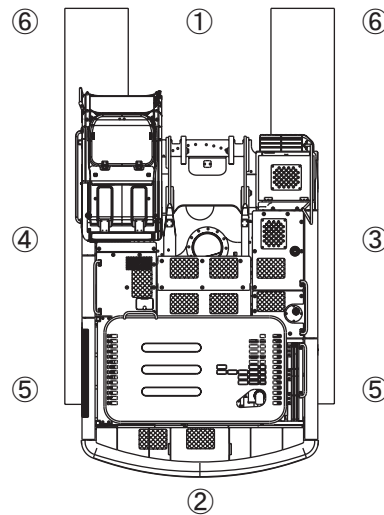

0-0194E

- | | |
|-------------------|--------------------------|
| ① FRONT | ④ LEFT-HAND SIDE |
| ② REAR | ⑤ TRAVEL REDUCTION GEARS |
| ③ RIGHT-HAND SIDE | ⑥ IDLER WHEELS |

Break-in

This product is shipped after full inspections and conditioning, however, extremely overloaded usage at the initial stage could lead the reduction in performance and life. Therefore, approx. initial 100 hours (indicated hours on the service meter) break-in is necessary.

Break-in should be conducted paying attention to the following points:

- Try to keep idling and warming for 5 minutes after starting the engine.
- Avoid operation under heavy load or at high speeds.
- Avoid any sudden start, acceleration or unnecessary sudden stop and quick turn.

Specified Work

This product is designed to use mainly in the following work:

- Excavation
- Land grading work
- Trenching work
- Loading work
- Demolition (Demolition specification vehicle only)

For Safe Driving

IMPORTANT:

Remove the protective (rust preventative) aluminum cover wrapped around the cylinder rods immediately after receiving the machine. If the machine is left with the covers on, water can collect on the inside of the cover, which will be the cause for rust to develop on the cylinder rod.

In the case of transportation by sea, sea water salt adheres to the machine making rust easier to develop. Immediately follow the measures below after receiving a machine that has been transported by sea. If the measures are not taken, the machine will develop rust easily.

1. Confirm that there are no salt deposits on the machine exterior. When salt deposits are suspected, wash the entire machine with water.

⚠ CAUTION

Do not use high pressure cleaning water directly on the alternator, battery and other electrical parts or wiring.

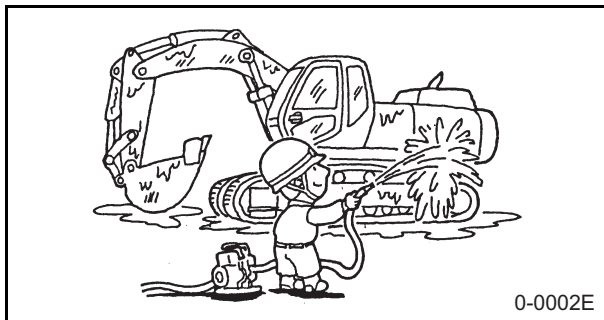

2. Performing Rust Prevention Operation.

⚠ CAUTION

Start the engine after you understand the operation methods.

- ① Set the engine at low~medium rpm and go through the warming up operation.
- ② Slowly operate each cylinder of the front attachment five strokes each.

3. If Storage Is To Be Continued
[Storage procedures for rust prevention.]

- ① Grease up each part of the attachment.

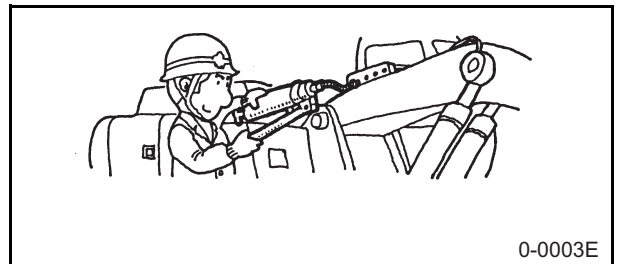

Storage for up to one month

- (1) Once a week operate each motion (attachment, swing, travel) with no load which performs rust prevention operation.
- ① Put the engine in low~medium rpm and perform the warming up operation.
- ② Slowly operate each cylinder of the front attachment five strokes each.

Storage for more than one month

- (1) Place each cylinder in the most retracted position and apply anti-rust oil to the exposed cylinder rod.

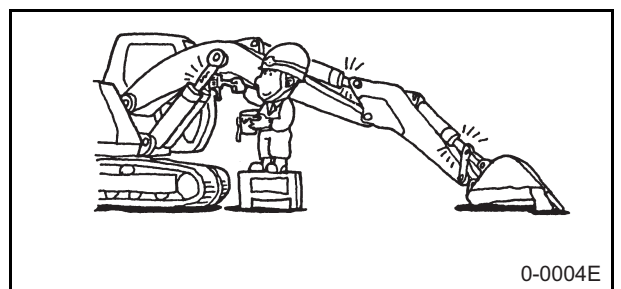

- (2) Perform rust-prevention operation once a month.
- ① Before performing the rust-prevention operation, remove the anti-rust oil (wipe off with kerosene, etc.).
- ② After finishing the rust prevention operation, fully retract each cylinder and apply anti-rust oil to the exposed cylinder rod.

For Safe Driving

SAFETY INSTRUCTIONS

Your safety and that of people around you depend on you. It is essential that you understand this manual for the correct operation, inspection, lubrication and maintenance of this machine.

Read this manual carefully and check that :

- You understand fully the symbols on the controls and the safety signs used in this manual and on the machine.
- You understand fully the speed, stability, braking and steering characteristics of the machine. If you are in any doubt, consult your CASE Dealer.

The safety messages in this manual concern situations which may arise during normal machine operation and servicing. These safety messages also indicate the different ways of coping with these situations. Other safety messages are used throughout the manual to indicate specific dangers.

Whatever type of work is being done (earthmoving, handling, drilling, etc.), the safety measures for private or public work-sites are those which conform to current regulations in the country concerned, or the type of operation concerned (mining, quarrying, tunnelling).

The safety instructions given in this manual are a summary of the basic rules to be respected at all times and do not exempt you from insurance requirements or from abiding by the highway code. Always keep this manual in the storage compartment "Pocket" provided for it. Make sure it is always complete and in good condition.

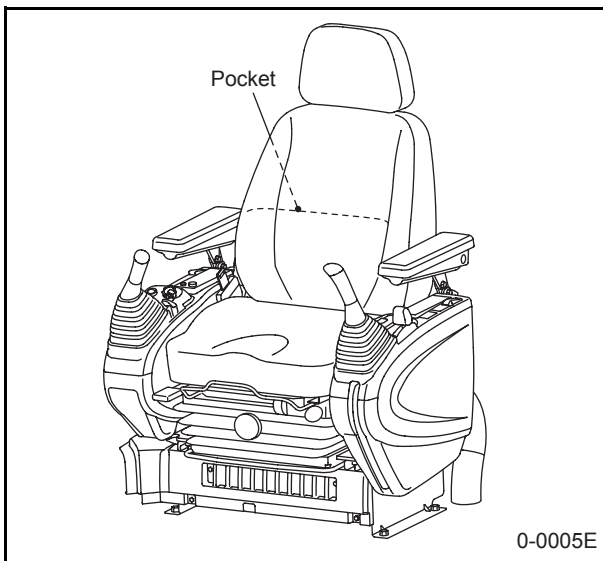

For Safe Driving

Warranty

In case faults occur to the machine, the warranty is valid within the range described in the warranty document.

Model and Serial number of manufacture

When ordering parts, obtaining information or assistance, always supply your LBX distributor with the type and serial number of your machine or accessories.

Write the following in the spaces below: The model number, serial number and year of manufacture of your machine, accessories and the serial number of the various hydraulic and mechanical components.

Machine

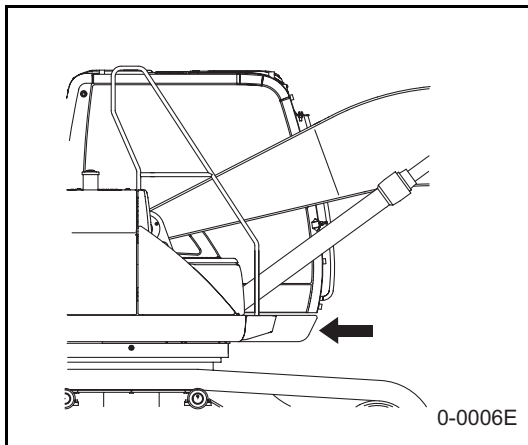

Excavator Identification _____

Model Number _____

Serial Number _____

Engine

Make and type _____

Serial number _____

Component serial numbers

Hydraulic pump _____

Swing reduction gear _____

Travel reduction gears _____

Travel control valve _____

Attachment control valve _____

Swing control valve _____

Table of Contents

| | | | |
|--|------------|---|------------|
| To the Owner | 0-1 | Operations (Attachment) | 2-19 |
| Safety Labels | 0-2 | Operations | 2-20 |
| For Safe Driving | 0-3 | Characteristics of Hydraulic Excavator | 2-20 |
| Safety Section | 0-7 | Cautions for operations | 2-20 |
| Precaution Identification Plates (DECALS) | 0-8 | Cautions for Interference | 2-21 |
| Identification Plates inside the Cabin | 0-8 | Special Attachments | 2-22 |
| Outside Identification Plate | 0-12 | Operating Instructions (Cautions) | 2-24 |
| Precaution Identification Plates on Parts (Examples) | 0-16 | Operating Instructions (Procedures) | 2-25 |
| Prior to Operation | 0-17 | Bucket: Turning Over and Replacement | 2-27 |
| Confirmation of Safety items | 0-19 | Bucket: Turning Over and Replacement | 2-27 |
| During Operation | 0-22 | On Completion of Daily Operations | 2-29 |
| While Traveling | 0-26 | On Completion of Daily Operations | 2-29 |
| After Operating | 0-27 | Operating in Cold Climates | 2-31 |
| While Transporting | 0-28 | Operating under Extreme Conditions | 2-32 |
| Before Regular Inspection & Maintenance | 0-29 | Transportation | 2-33 |
| Inspection and Maintenance | 0-30 | Loading and Unloading | 2-33 |
| Instruments and Controls | 1-0 | Switch settings during loading and unloading | 2-33 |
| Location of Components | 1-1 | Transportation | 2-33 |
| Overall View | 1-1 | Storing | 2-38 |
| Operator's Cab | 1-2 | Inspections and Maintenance | 3-0 |
| Seat and Console | 1-3 | General Cautions | 3-1 |
| Right Panel | 1-4 | Periodic Maintenance Check List | 3-2 |
| Console right side front | 1-4 | Daily Inspections (Prior to Operation) | 3-2 |
| Explanation of device | 1-5 | Periodic Maintenance Check List | 3-3 |
| Console right side front | 1-5 | Fuel / Lubricants for Different Ambient Temperature | |
| Right Console | 1-6 | Settings | 3-4 |
| Left Console | 1-9 | Genuine CASE Company LLC Parts and Elements | 3-5 |
| Right Panel | 1-11 | Disposable Items | 3-6 |
| Control Levers | 1-18 | Grease / Oil and Elements | 3-7 |
| Operator's Seat | 1-21 | Inspection Prior to Operation | 3-9 |
| Operator's Cab | 1-23 | Inspections Prior to Operation | 3-9 |
| Radio | 1-28 | Greasing Attachments | 3-13 |
| Air Conditioner | 1-30 | Greasing Front Attachment Pins | 3-13 |
| Fuses | 1-37 | Fuel System | 3-15 |
| Battery | 1-38 | Fuel | 3-15 |
| Starting the Engine by Using Booster Cables | 1-39 | Fuel Refilling and Fuel Level Checking | 3-18 |
| Anti-theft Protection | 1-41 | Drainage of Water and Sediments in the Fuel Tank | |
| Anti-theft Protection | 1-41 | | 3-18 |
| Using the Anti-theft Protection Function | 1-42 | Draining Water from the Pre Fuel Filter | 3-19 |
| Operating Instructions | 2-0 | Pre Fuel Filter Replacement | 3-20 |
| Operation of New Machine | 2-1 | Draining Water from the Fuel Filter (Main) | 3-21 |
| Using a New Machine | 2-1 | Fuel Filter (Main) Replacement | 3-21 |
| Daily Inspections | 2-2 | Engine | 3-23 |
| Daily Inspections | 2-2 | Engine Oil Replacement | 3-23 |
| Starting and Stopping the Engine | 2-4 | Engine Oil Filter Replacement | 3-23 |
| Inspections before Starting the Engine | 2-4 | Cooling System | 3-25 |
| Starting the Engine | 2-5 | Inspecting and Refilling Coolant | 3-25 |
| Inspections after Starting the Engine | 2-6 | Replacing the Coolant | 3-26 |
| Stopping the Engine (Normal Operation) | 2-7 | Cleaning and Inspecting the Radiator Net and Fin | |
| Warm-up Operation | 2-8 | | 3-28 |
| Warm-up Operation | 2-8 | Cleaning and Replacing the Air Cleaner (double ele- | |
| Operations (Traveling) | 2-10 | ments) | 3-29 |
| Operations (Swing) | 2-18 | Inspection and Adjustment of Fan Belt | 3-31 |
| Swing Operation | 2-18 | Bolt Torque | 3-32 |
| Operations (Attachment) | 2-19 | Bolt and Nut Torque | 3-32 |
| Operations | 2-20 | Hydraulic Oil | 3-36 |
| Characteristics of Hydraulic Excavator | 2-20 | Hydraulic Oil Level Inspection | 3-36 |
| Cautions for operations | 2-20 | Refilling Hydraulic Oil | 3-36 |
| Cautions for Interference | 2-21 | | |
| Special Attachments | 2-22 | | |
| Operating Instructions (Cautions) | 2-24 | | |
| Operating Instructions (Procedures) | 2-25 | | |
| Bucket: Turning Over and Replacement | 2-27 | | |
| Bucket: Turning Over and Replacement | 2-27 | | |
| On Completion of Daily Operations | 2-29 | | |
| On Completion of Daily Operations | 2-29 | | |
| Operating in Cold Climates | 2-31 | | |
| Operating under Extreme Conditions | 2-32 | | |
| Transportation | 2-33 | | |
| Loading and Unloading | 2-33 | | |
| Switch settings during loading and unloading | 2-33 | | |
| Transportation | 2-33 | | |
| Storing | 2-38 | | |



Table of Contents

| | | | |
|---|-------------|---|------|
| Draining Water and Sediment from the Hydraulic Oil Tank | 3-37 | Breakers | 5-2 |
| Hydraulic Oil Management | 3-38 | Handling the Breaker (Attachment)..... | 5-2 |
| Hydraulic Oil Replacement..... | 3-38 | When Using a Hydraulic Breaker | 5-3 |
| Bleeding Air from the Hydraulic Components | 3-39 | Importance of Hydraulic oil Control | 5-6 |
| Air Bleeding Procedures | 3-39 | Crusher | 5-8 |
| Air Bleeding from Hydraulic Pump | 3-39 | Using the Crusher (Attachment) | 5-8 |
| Air Bleeding from Cylinder | 3-40 | Special Attachment | 5-11 |
| Air Bleeding from Swing Motor..... | 3-40 | Controlling Rocker switch | 5-13 |
| Cleaning and Replacing Suction Filter | 3-41 | Position of control pedal..... | 5-14 |
| Replacing Return Filter | 3-41 | | |
| Replacing Air Breather Element..... | 3-42 | | |
| Replacing Pilot Oil Filter Element..... | 3-42 | | |
| Replacement Intervals for Hydraulic Oil and Filters when Using Breaker..... | 3-43 | | |
| Checking Hoses and Lines | 3-43 | | |
| Battery | 3-44 | | |
| Battery Inspection and Charge..... | 3-44 | | |
| Upper Frame | 3-46 | | |
| Turntable Bearing Greasing | 3-46 | | |
| Greasing Swing Ring Gear | 3-46 | | |
| Swing Unit | 3-47 | | |
| Oil Level Inspection and Refilling of Swing Reduction Gear | 3-47 | | |
| Oil Replacement for Swing Reduction Gear | 3-47 | | |
| Greasing Swing Reduction Gear..... | 3-48 | | |
| Travel Unit | 3-49 | | |
| Travel Reduction Gear | 3-49 | | |
| Oil Level Inspection and Refilling of Travel Reduction Gear | 3-49 | | |
| Oil Replacement for Travel Reduction Gear | 3-49 | | |
| Inspecting Upper/Lower Take-up Roller (Idler Wheel) | 3-50 | | |
| Inspection and Tightening of Shoe Plate | 3-50 | | |
| Cleaning Crawler..... | 3-50 | | |
| Inspection and Adjustment of Track Shoe Tension | 3-51 | | |
| Bucket | 3-52 | | |
| Replacing Bucket Teeth: Standard type (Length Pin Type)..... | 3-52 | | |
| Replacing Bucket Tooth: Standard type (Side pin type) | 3-54 | | |
| Replacing Bucket Teeth: Heavy Digging Type..... | 3-55 | | |
| Adjustment of Bucket Backlash..... | 3-56 | | |
| Air Conditioner | 3-57 | | |
| Inspection and Care of Air Conditioner | 3-57 | | |
| Routine Replacement Safety Parts | 3-61 | | |
| Troubleshooting | 3-62 | | |
| Contacting Us | 3-67 | | |
| Specifications | 4-0 | | |
| Conversion Factors | 4-1 | | |
| CONVERSION FACTORS..... | 4-1 | | |
| Specifications | 4-2 | | |
| Optional Components | 5-0 | | |
| Selector Valve | 5-1 | | |
| Selector valve (2-way)..... | 5-1 | | |

Safety Section

WARNING

**You must read this safety section carefully.
This section contains important safety information.**

The  symbols on precaution film labels are attached to machines in order to prevent personal injury. Before starting operations, read carefully the indications on film labels with  symbols.

It is a very difficult task to cover and handle all possible dangers in this manual. For this reason, the descriptions on precaution film labels do not always cover everything. Try to understand fully this manual and drive and operate properly, paying special attention to prevent damage to the machine or personal injury.

Contents of the manual

- Precaution Identification Plates (DECALS)
- Prior to Operation
- Confirmation of Safety items
- During Operation
- While Traveling
- After Operating
- While Transporting
- Before Regular Inspection & Maintenance
- Inspection and Maintenance

Always keep the precaution ID label clear and readable.

When the plate gets dirty:

Clean the plate with water or washing agent. Don't use any gasoline or organic solvent.

If a precaution identification plate is extremely dirty and the dirt is difficult to remove, replace it with a new one. Before changing it, make sure it is the same type.

In case Precaution Identification Plates are lost or damaged:



Ask for a new precaution identification plate at the nearest approved sales shop.

Before changing it, make sure it is the same type.

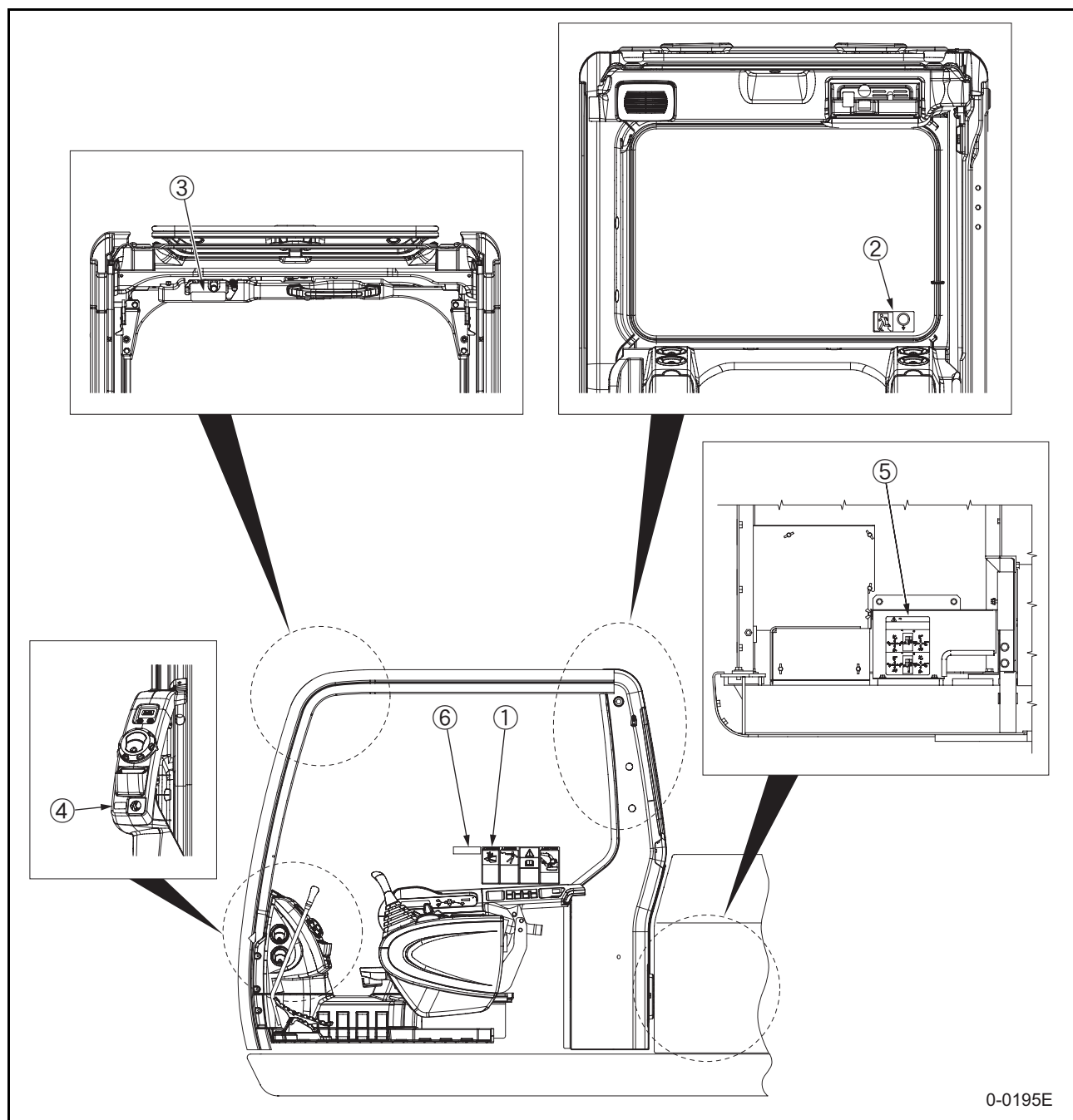
Identification Plates inside the Cabin

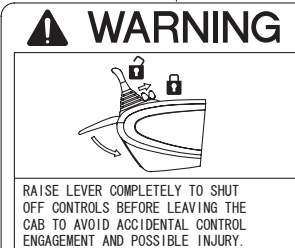

① WARNING Label KHP12142

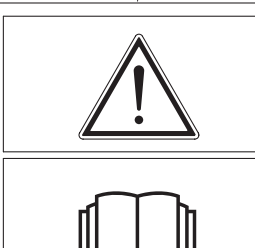
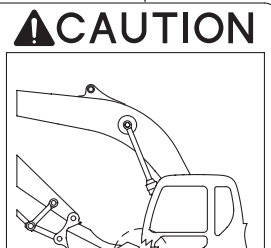
| | | | |
|---|---|---|---|
| A ↓ | C ↓ | D ↓ | E ↓ |
|  <p>WARNING</p> <p>RAISE LEVER COMPLETELY TO SHUT OFF CONTROLS BEFORE LEAVING THE CAB TO AVOID ACCIDENTAL CONTROL ENGAGEMENT AND POSSIBLE INJURY.</p> |  <p>DANGER</p> <p>ELECTROCUTION HAZARD.</p> <p>CONTACT WITH MACHINE OR GROUND MAY CAUSE DEATH OR BODILY INJURY. KEEP ALL PARTS OF MACHINE AND LOAD AT LEAST 15 FEET (4.57M) AWAY FROM ALL ELECTRICAL POWER LINES OR SUCH DISTANCE AS SPECIFIED BY LOCAL SAFETY CODES.</p> |  <p>WARNING</p> <p>IMPROPER MACHINE OPERATION AND MAINTENANCE CAN CAUSE INJURY OR DEATH. READ AND STUDY THE OPERATOR'S MANUAL AND ALL SAFETY MESSAGES. LEARN AND PRACTICE SAFE USE OF CONTROLS. ALWAYS OPERATE PROPERLY. INSPECT AND MAINTAIN MACHINE DAILY.</p> |  <p>CAUTION</p> <p>ATTACHMENT INTERFERENCE. MACHINE DAMAGE MAY RESULT.</p> <p>DO NOT ALLOW THE ATTACHMENT, LOAD OR OTHER DEVICES TO CONTACT THE CAB OR MACHINE.</p> <p style="text-align: right; font-size: small;">KHP12142-00</p> |
| ↑ B | | | |

0-0009E

Ⓐ Raise gatelock lever

Raise lever completely to shut off controls before leaving the cab to avoid accidental control engagement and possible injury.

 **WARNING**



RAISE LEVER COMPLETELY TO SHUT OFF CONTROLS BEFORE LEAVING THE CAB TO AVOID ACCIDENTAL CONTROL ENGAGEMENT AND POSSIBLE INJURY.

0-0010E

Ⓑ Exchange of control function

WARNING

CONTROL FUNCTIONS ON THIS MACHINE ARE INTERCHANGABLE. ONLY AN AUTHORIZED DEALER REPRESENTATIVE IS ALLOWED TO MODIFY THE CONTROL PATTERN. WHEN A MODIFICATION HAS BEEN MADE THE REPRESENTATIVE MUST CHANGE THE DECAL TO MATCH THE NEW CONTROL PATTERN. FAILURE TO CHANGE THE DECAL COULD RESULT IN DEATH OR SERIOUS INJURY

0-0046E

Safety

Precaution Identification Plates (DECALS)

© Electric shocks

If you let the machine go too close to electric wires, you could get an electric shock. Keep a safe distance and away from electric wires. Guidelines for Safe Distances.

| Voltage | Safe Distance |
|-------------------|------------------------|
| 6,600 V or less | 6.6 ft (2 m) or more |
| 22,000 V or less | 9.8 ft (3 m) or more |
| 66,000 V or less | 13.1 ft (4 m) or more |
| 154,000 V or less | 16.4 ft (5 m) or more |
| 187,000 V or less | 19.7 ft (6 m) or more |
| 275,000 V or less | 23.0 ft (7 m) or more |
| 500,000 V or less | 36.1 ft (11 m) or more |

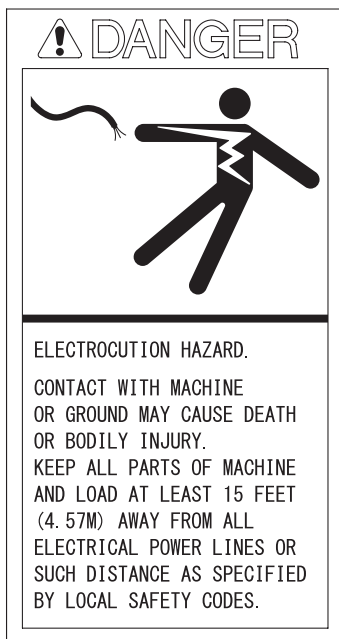

0-0012E

Ⓓ Read manual before driving and maintenance

This is very important. You must read this carefully. You must read the manual before driving, maintaining, disassembling/assembling or transporting your machine.

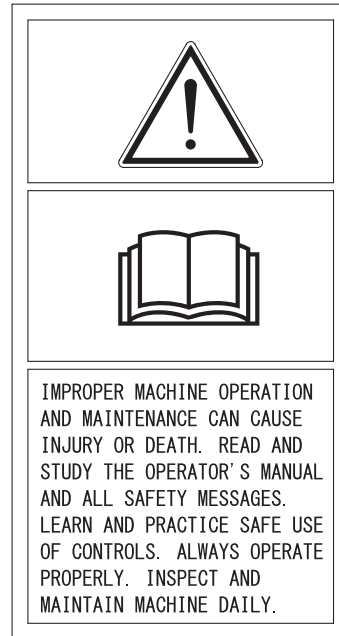

0-0013E

Ⓔ Attachment interferece with cab

The bucket teeth may hit the cab, depending on the type of attachment. Exercise care when operating a bucket near the cab.

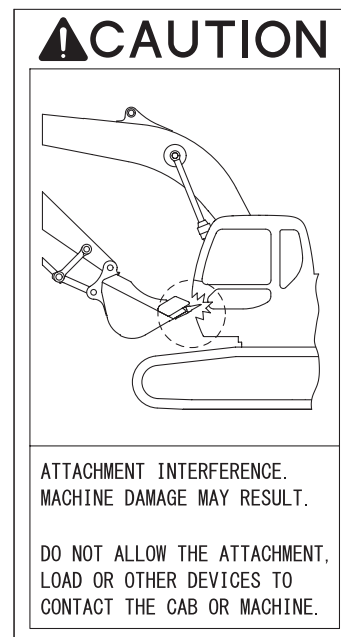

0-0014E

② Emergency exit KHP 11600

In an emergency, pull the pull-ring on the rear window to allow the window to be detached so that you can escape through the opening rear window out of the machine.



KHP11600-00

0-0011

③ Caution against the fall of front window KHP12170

There is a danger of an injury due to possible sliding fall of the stored front window.

Be sure to lock the front window securely at the position to be stored.



KHP12170-00
0-0015E

④ For use of cigarette lighter socket KHP11590

The cigarette lighter located in the front-right console is of DC24V rating.

It is strictly prohibited to connect any of the equipment of 12V rating as this causes it to be damaged.



KHP11590-00

0-0013

⑤ Point to notice when changing control method KHP12300

In order to prevent an accident caused by wrong operation, be sure to operate the machine after content of the control decal in the cab matches to the function of the machine.

If not, replace the control decal before operation, or change the control method.

Be sure to stop the engine before changing the control method.

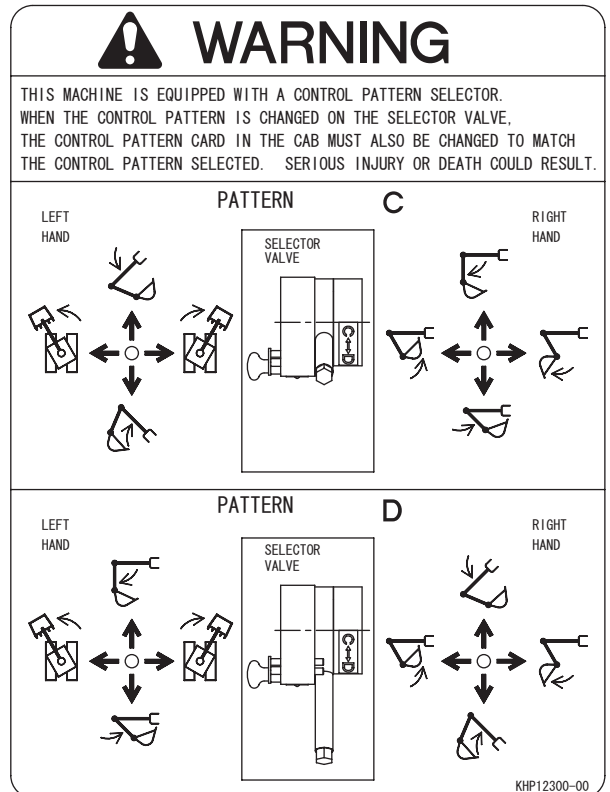

KHP12300-00

0-0016E

⑥ Control pattern selector KHP1587

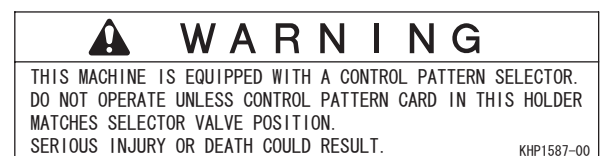

KHP1587-00

0-0017E

Outside Identification Plate

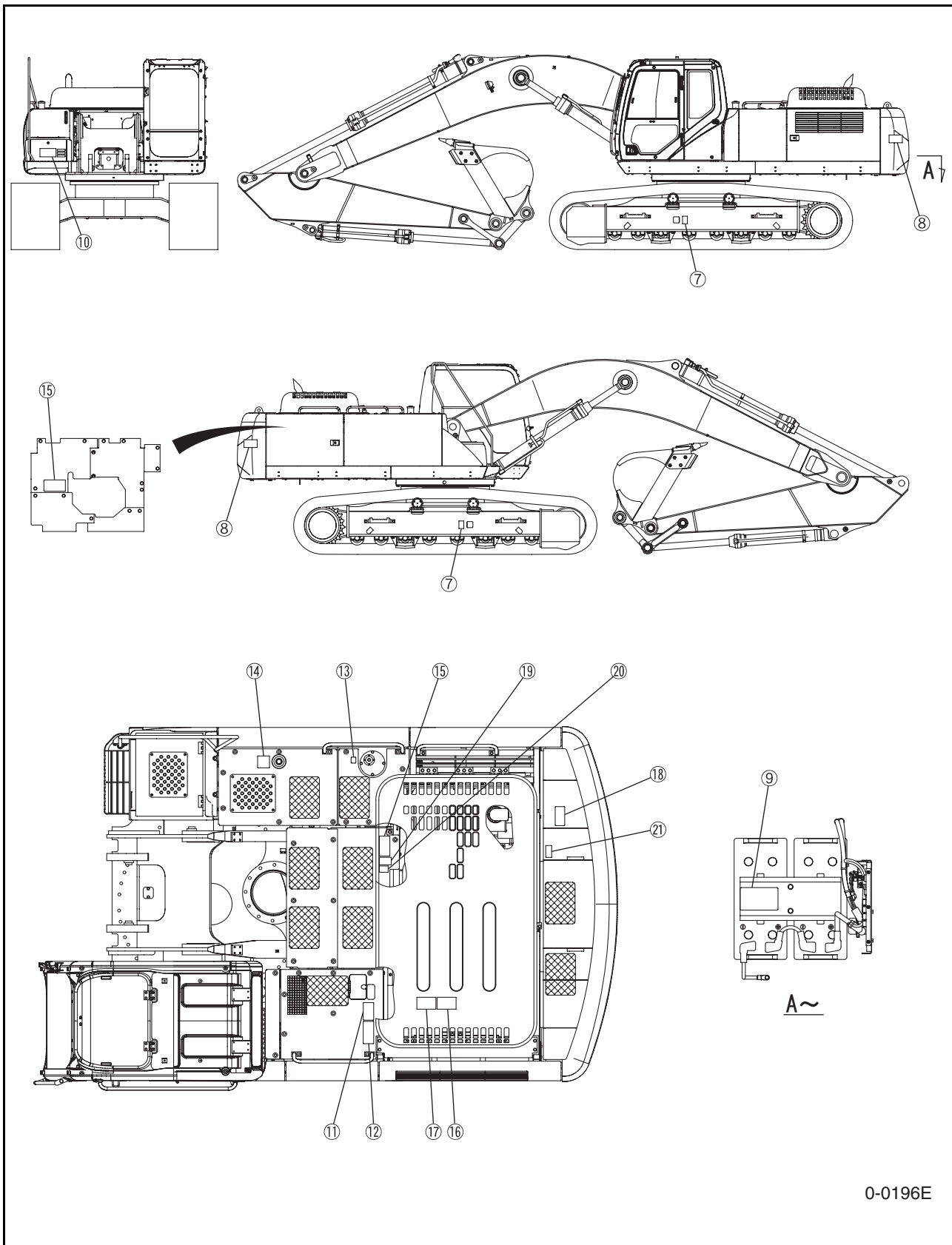

⑦ Shoe (crawler belt) tension KHP1014

Plug could pop out from the shoe (crawler belt) tension adjustment device.

When releasing the shoe, read the manual and handle shoes properly.



0-0019E

⑧ Keep out of the range of turns KHP1532

When the machine makes a turn, you may be caught in the upper part of the turning body.

Do not attempt to enter within the range of the turns.

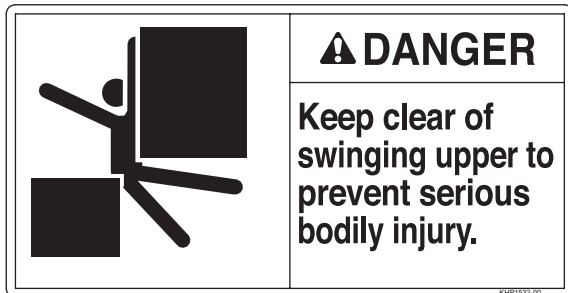

0-0086E

⑨ Battery explosion KHP1536

The wrong handling of battery causes explosion itself.

You must read the manual before maintaining battery.

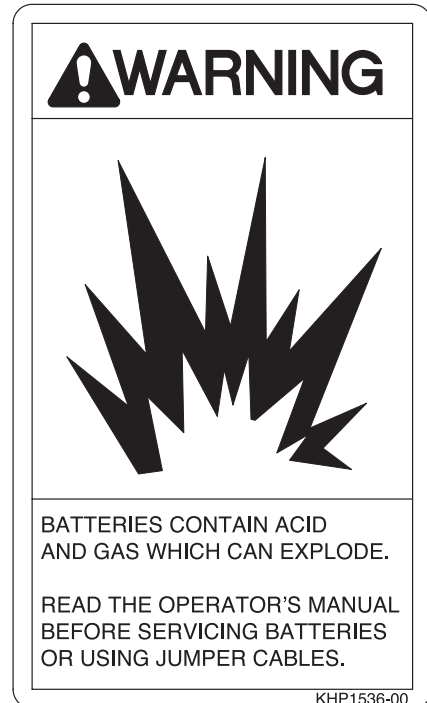

0-0032E

⑩ Electric shocks KHP0210

If you let the machine go too close to electric wires, you could get an electric shock.

Keep a safe distance and away from electric wires. Guidelines for Safe Distances.

| Voltage | Safe Distance |
|-------------------|------------------------|
| 6,600 V or less | 6.6 ft (2 m) or more |
| 22,000 V or less | 9.8 ft (3 m) or more |
| 66,000 V or less | 13.1 ft (4 m) or more |
| 154,000 V or less | 16.4 ft (5 m) or more |
| 187,000 V or less | 19.7 ft (6 m) or more |
| 275,000 V or less | 23.0 ft (7 m) or more |
| 500,000 V or less | 36.1 ft (11 m) or more |

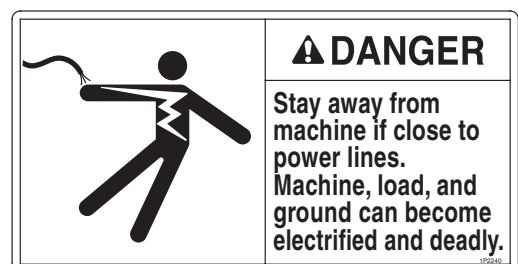

0-0020E

⑪ Entanglement KHP1533

Entanglement in rotating parts of the fun could cause injury.

Always stop the rotating engine when conducting inspection and maintenance.

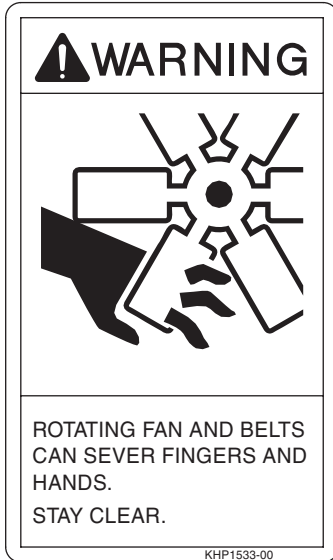

0-0021E

⑫ Relieving pressure KHP1534

You can relieving the pressure from the reservoir by removing cap.



0-0022E

⑬ Relieving pressure KHP1542

You can relieving the pressure from the reservoir before removing tank cap.

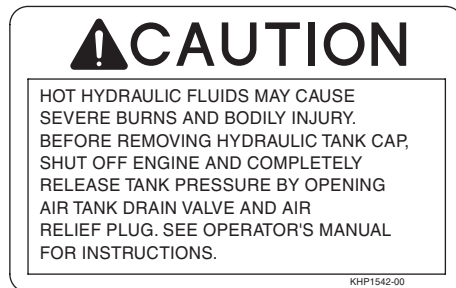

0-0023E

⑭ Diesel Fuel KHP11681

The location of the fuel tank.

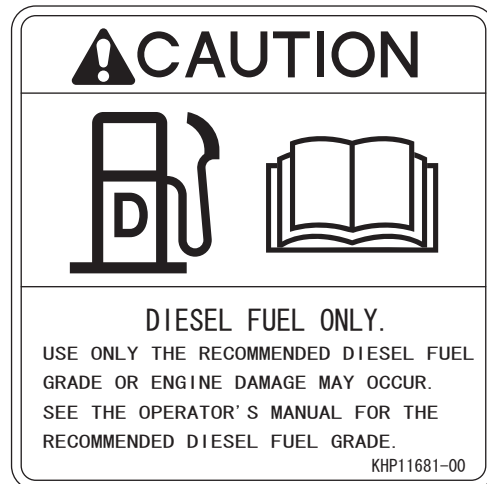

0-0024E

⑮ Hot surfaces KHP1535

The exhaust system must never be touched while the engine is running or immediately after the engine has stopped.

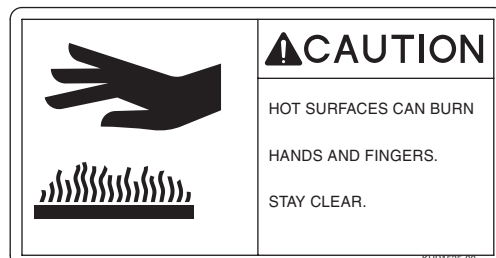

0-0025E

- ⑩ Do not walk on Engine cover
KHP1011



0-0026E

- ⑨ Start Engine from Operator Seat
KHP0713

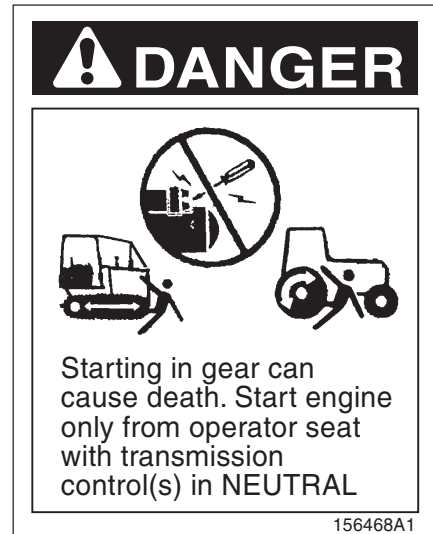

0-0075E

- ⑦ Engine Hood handling KHP1010



0-0027E

- ⑩ Jumper Cable Connection
KHP0700

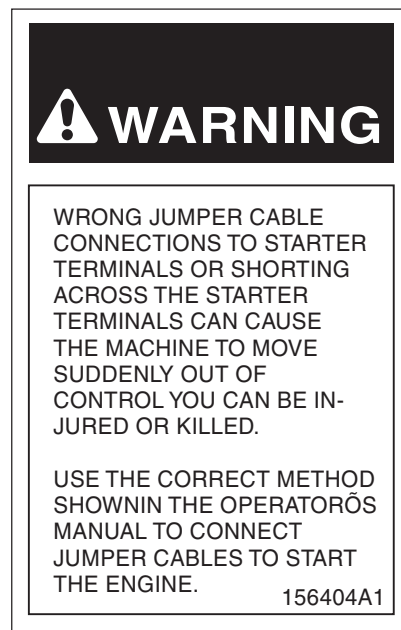

0-0076E

- ⑧ Fall attention KHP12210

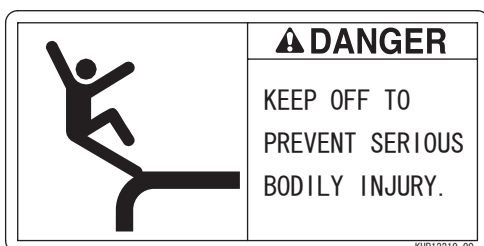

0-0028E

- ⑩ Do not open high pressure fuel system KHP13150

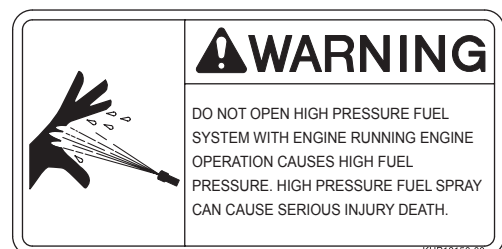

0-0114E

Safety

Precaution Identification Plates (DECALS)

Precaution Identification Plates on Parts (Examples)

Battery



0-0029E

This decal is on the batteries and draws attention to the risks and precautions to be taken when handling batteries. See "Batteries" in the "Electrical System" Section.

Accumulator

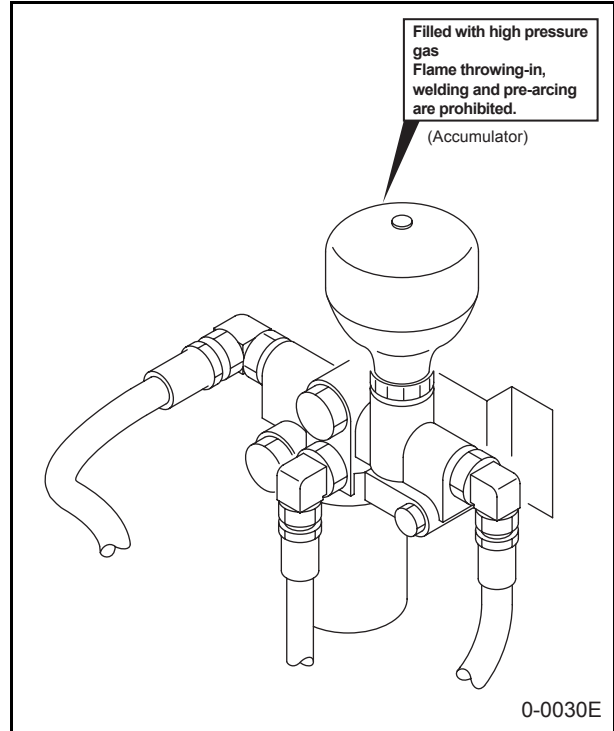

Radiator Cap

