

CX300C
Tier 4
Crawler Excavator

OPERATOR'S MANUAL

Part number 84415529

1st edition English

March 2011



Contents

1 GENERAL INFORMATION

Safety rules and signal word definitions	1-1
Safety rules	1-2
Note to the Owner	1-3
Product identification	1-5
Left, right, front and rear of the machine	1-8
Electro-magnetic interference (EMC).....	1-8
Description of the main components	1-9

2 SAFETY INFORMATION

Safety rules	2-1
Safety decals	2-7
Hand signals.....	2-21

3 CONTROLS/INSTRUMENTS

ACCESS TO OPERATOR'S PLATFORM

FRAME AND CAB - Access/Exit	3-1
Position of the operator's compartment controls and accessories	3-3

OPERATOR'S SEAT

Air suspension seat adjustments	3-5
---------------------------------------	-----

FORWARD CONTROLS

Hand control levers and pedals	3-9
Windshield.....	3-13
Front lower window	3-14
Front right hand console.....	3-15
System display and function control panel	3-16
Monitor switches.....	3-22
Menu screen display	3-25
Diesel particulate diffuser.....	3-33
Clock adjustment	3-40

LEFT-HAND SIDE CONTROLS

Left-hand control arm.....	3-41
Heating, ventilation or air-conditioning control	3-42
Function cancellation lever and safety bar	3-46
Cab internal lighting	3-47
Emergency exit hammer	3-47
Tool quick coupler locking and unlocking control switch (Optional)	3-48
Sliding windows on door.....	3-48

RIGHT-HAND SIDE CONTROLS

Right-hand control arm	3-49
Cab radio	3-50
Right hand console	3-52
Coat hanger hook	3-53
Cup holder.....	3-53

REARWARD CONTROLS

Fuse box.....	3-54
Magazine rack	3-54
Refrigerated compartment.....	3-55
Storage compartment	3-55

OVERHEAD CONTROLS

Roof curtain.....	3-56
Roof hatch.....	3-56
Sun shield (optional)	3-56

EXTERIOR CONTROLS

Fuel tank.....	3-57
Rear view mirrors.....	3-58
Cameras.....	3-59
Front storage box.....	3-59
Side doors	3-60
Engine hood.....	3-61
Lower panels	3-62
Windshield washer reservoir	3-62
Load handling eyes.....	3-63
Towing holes.....	3-64
Safety valves (optional)	3-65
Optional tool supply valves (optional)	3-65
Fuel tank filler pump (if equipped)	3-66
Cab protection (ROPS and FOPS).....	3-68

4 OPERATING INSTRUCTIONS

COMMISSIONING THE UNIT

USER PLATFORM - Operating.....	4-1
USER PLATFORM - Running-in Procedure.....	4-3

STARTING THE UNIT

Anti-theft protection.....	4-4
Starting the engine	4-7
Bringing the machine up to operating temperature.....	4-9
Engine operation	4-10
Operating the machine in hot or cold weather.....	4-11
Machine operation.....	4-12

STOPPING THE UNIT

Stopping the engine	4-13
---------------------------	------

MOVING THE UNIT

Machine travel	4-14
Handling the machine	4-17
Load handling	4-18
Operating the machine	4-20
Quick coupler (optional)	4-22
Lowering the attachment in the event of a failure	4-26
Auxiliary hydraulic circuits	4-27
Optional hand control levers configuration	4-33

PARKING THE UNIT

Parking the Machine.....	4-34
--------------------------	------

5 TRANSPORT OPERATIONS

SHIPPING TRANSPORT

Transporting the machine	5-1
--------------------------------	-----

RECOVERY TRANSPORT

Towing	5-6
--------------	-----

6 MAINTENANCE

GENERAL INFORMATION

Basic instructions	6-1
Fluids, fuels and lubricants	6-4
Fluid capacities and lubricant specifications	6-9
Grease points.....	6-10
Levels.....	6-18
Engine	6-20
Cooling system	6-23
Fuel system.....	6-26
Releasing pressure in the hydraulic system.....	6-32
Hydraulic circuit.....	6-34
Air filter	6-43
Swing reduction gear	6-46
Travel reduction gears.....	6-48
Tracks	6-49
Track rollers and idler wheels	6-52
Radiator and coolers	6-53
Fan and alternator drive belt	6-55
Adjustment of engine valve rocker clearances	6-56
Fuel tank filter	6-56
Fire extinguisher (not supplied)	6-57

Protecting the Electrical/Electronic Systems During Charging or Welding	6-58
Cab protection (ROPS and FOPS) (optional)	6-59
Machine inspection and cleaning	6-59
Checking the machine settings	6-59
Plastic and resin parts	6-60
Checking the cylinders for leaks	6-60
Tooth tip wear limits on the backhoe bucket	6-60
Replacing a tooth on a backhoe bucket	6-61
Replacing a backhoe bucket	6-62
Checking the opening of the quick coupler locking hook (optional)	6-63
Air conditioning	6-65
Diesel particulate diffuser	6-69
Gas spring inspection	6-70
Torque specifications for hardware	6-71
Fuses	6-72
Batteries	6-74
Alternator	6-78
Starter motor	6-78
Bulb replacement	6-79

MAINTENANCE CHART

Maintenance Chart	6-82
-------------------------	------

STORAGE

Preparation for storage	6-86
Periodic checks	6-87
Starting up after storage	6-88

7 TROUBLESHOOTING

FAULT CODE RESOLUTION

Engine troubleshooting	7-1
------------------------------	-----

8 SPECIFICATIONS

General specification	8-1
Noise level	8-3
Weight	8-3
Dimension	8-4

1 - GENERAL INFORMATION

Safety rules and signal word definitions

Personal safety





This is the safety alert symbol. It is used to alert you to potential personal injury hazards. Obey all safety messages that follow this symbol to avoid possible death or injury.

Throughout this manual you will find the signal words DANGER, WARNING, and CAUTION followed by special instructions. These precautions are intended for the personal safety of you and those working with you.

Read and understand all the safety messages in this manual before you operate or service the machine.

 DANGER indicates a hazardous situation which, if not avoided, will result in death or serious injury.

 WARNING indicates a hazardous situation which, if not avoided, could result in death or serious injury.

 CAUTION indicates a hazardous situation which, if not avoided, could result in minor or moderate injury.

FAILURE TO FOLLOW DANGER, WARNING, AND CAUTION MESSAGES COULD RESULT IN DEATH OR SERIOUS INJURY.

Machine safety

NOTICE: Notice indicates a situation which, if not avoided, could result in machine or property damage.

Throughout this manual you will find the signal word Notice followed by special instructions to prevent machine or property damage. The word Notice is used to address practices not related to personal safety.

Information

NOTE: Note indicates additional information which clarifies steps, procedures, or other information in this manual.

Throughout this manual you will find the word Note followed by additional information about a step, procedure, or other information in the manual. The word Note is not intended to address personal safety or property damage.

Safety rules

CALIFORNIA

PROPOSITION 65 WARNING

Diesel engine exhaust and some of its constituents
are known to the State of California to cause cancer,
birth defects and other reproductive harm.

Battery post, terminals and related accessories
contain lead and lead compounds.

Wash hands after handling

Note to the Owner

IMPROPER OPERATION OF THIS MACHINE CAN CAUSE INJURY OR DEATH. BEFORE USING THIS MACHINE, MAKE CERTAIN THAT EVERY OPERATOR:

- Is instructed in safe and proper use of the machine.
- Reads and understands the Manual(s) pertaining to the machine.
- Reads and understands ALL Safety Decals on the machine.
- Clears the area of other persons.
- Learns and practices safe use of machine controls in a safe, clear area before operating this machine on a job site.

It is your responsibility to observe pertinent laws and regulations and follow CASE instructions on machine operation and maintenance.

Your machine has been designed and built to the highest standards of quality. It conforms to all current safety regulations. However, the risk of accidents can never be completely excluded. That is why it is essential to observe elementary safety rules and precautions.

Read this manual carefully, paying particular attention to the instructions concerning safety, operation and maintenance so as to avoid the risk of injury while operating or servicing the machine.

The standard attachments and tools of this machine are designed to carry out all kinds of earthmoving and rehandling operations. If you want to use this machine to handle a load (pipes, culverts, formwork, etc.), make sure that it is designed to carry out this kind of work. For this type of application, the machine must be equipped with safety valves, a load handling chart corresponding to the type of machine and its attachment and a load fixing point. All legal requirements must also be strictly observed.

Do not use this machine for any application or purpose other than those described in this manual. If the machine is to be used for work involving the use of special attachments, accessories or equipment, consult your CASE Dealer in order to make sure that any adaptations or modifications made are in keeping with the machine's technical specifications and with prevailing safety requirements.

Any modification or adaptation which is not approved by the manufacturer may invalidate the machine's initial conformity with safety requirements.

The machine must undergo regular inspections, the frequency of which varies according to the type of use. Consult your CASE Dealer.

The engine and fuel system on your machine is designed and built to government emissions standards. Tampering by dealers, customers, operators and users is **STRICTLY PROHIBITED BY LAW**. Failure to comply could result in government fines, rework charges, invalid warranty, legal action and possible confiscation of the machine until rework to original condition is completed. Engine service and/or repairs must be done by a certified technician only.

Your CASE Dealer can provide after-sales service and genuine CASE spare parts, your guarantee of quality and match.

You can obtain manuals on the operation, maintenance and repair of your machine from your CASE Dealer. To ensure quick and efficient service, consult your CASE Dealer for assistance in ordering the correct manuals for your machine.

Your CASE Dealer can deal with orders for operator's manuals, parts catalogues and service manuals.

Always give the type and serial number of your machine so that your CASE Dealer can supply you with the right manuals for your machine.

CNH America LLC. Company reserves the right to make changes in the specification and design of the machine without prior notice and without incurring any obligation to modify units previously sold.

The description of the models shown in this manual has been made in accordance with the technical specifications known as of the date of design of this document.

All data given in this manual is subject to production variations. Dimensions and weights are provided with approximate values and the machine fitting shown in the illustrations may not correspond with standard models. For precise information on specific machine models and versions, please consult your CASE Dealer.

Reproduction or translation, even partial, is prohibited without written authorization from **CNH America LLC.** Company.

Copyright 2011 CNH America LLC
Issued March 2011

Product identification

CX300C HYDRAULIC CRAWLER EXCAVATORS

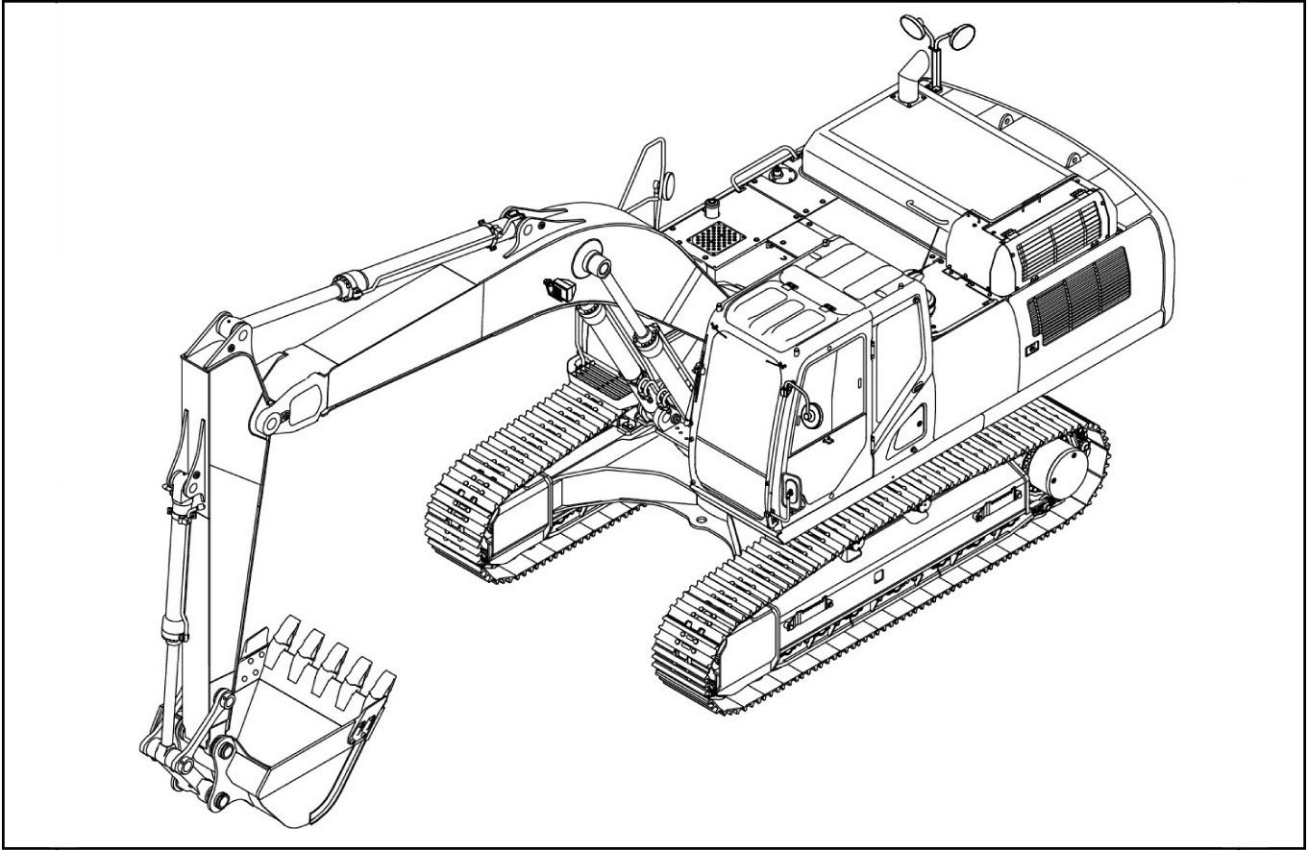

1JOA94-003 1

Dealer's Stamp



BLANCTPB1 2

TYPE, SERIAL NUMBER AND YEAR OF MANUFACTURE OF THE MACHINE

When ordering parts, obtaining information or assistance, always supply your CASE Dealer with the type and serial number of your machine or accessories.

Write the following in the spaces below: the type, serial number and year of manufacture of your machine, accessories and the serial numbers of the various hydraulic and mechanical components

Machine

(1) Type / Model and Category:
(Hydraulic Excavator) **CX300C**.

(2) Serial number:

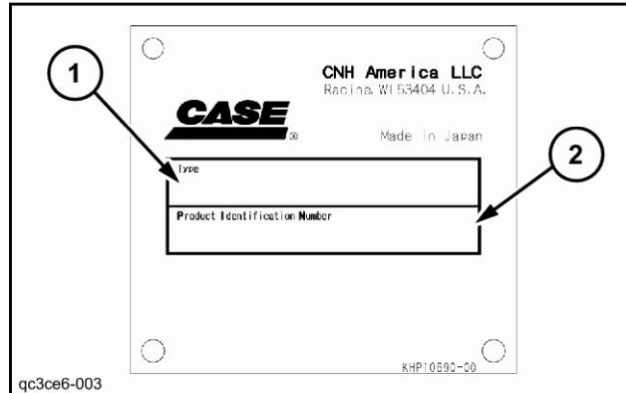

QC3CE6-003 3

Engine

Make and type: **ISUZU AL - 6HK1X**

Serial number:

ATTENTION: The engine and fuel system on your machine is designed and built to government emissions standards. Tampering by dealers, customers, operators and users is **STRICTLY PROHIBITED BY LAW**. Failure to comply could result in government fines, rework charges, invalid warranty, legal action and possible confiscation of the machine until rework to original condition is completed. Engine service and/or repairs must be done by a certified technician only.

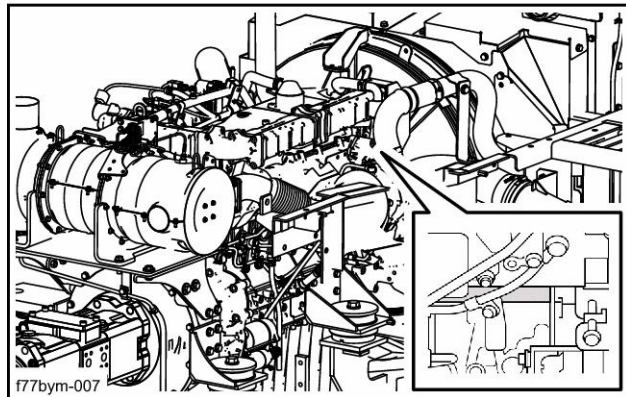

F77BYM-007 4

ID Label

It is attached to the cylinder head cover.



F77BYM-006 5

Component serial numbers

Hydraulic pump:

Swing reduction gear:

Travel reduction gears:

Travel control valve:

Attachment control valve:

Swing control valve:

Cab protection (F.O.P.S.) (optional)

Complies with **ISO 10262** level 2 standard.

Identification number:

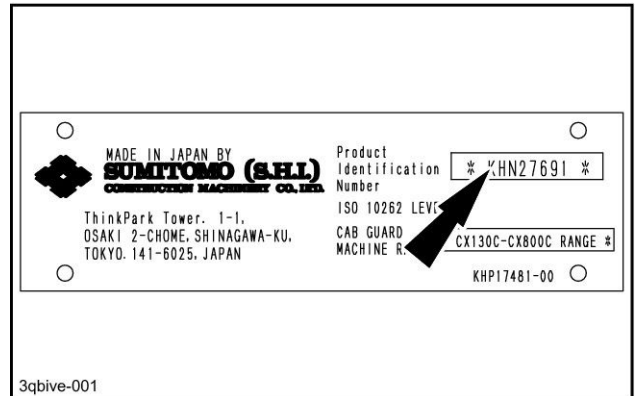

Structure protection (R.O.P.S.)

Complies with **ISO 12117-2**

Identification number:



Left, right, front and rear of the machine

The terms "Right", "Left", "Front" and "Rear" are used in this manual to indicate the sides as they are seen from the operator's seat when the cab is over the idler wheels.

The illustration opposite shows the machine in normal TRAVEL position. In normal TRAVEL position, the cab is over the idler wheels. The travel reduction gears are at the rear of the upperstructure.

- (A) FRONT
- (B) REAR
- (C) RIGHT-HAND SIDE
- (D) LEFT-HAND SIDE
- (E) TRAVEL MOTORS
- (F) IDLER WHEELS

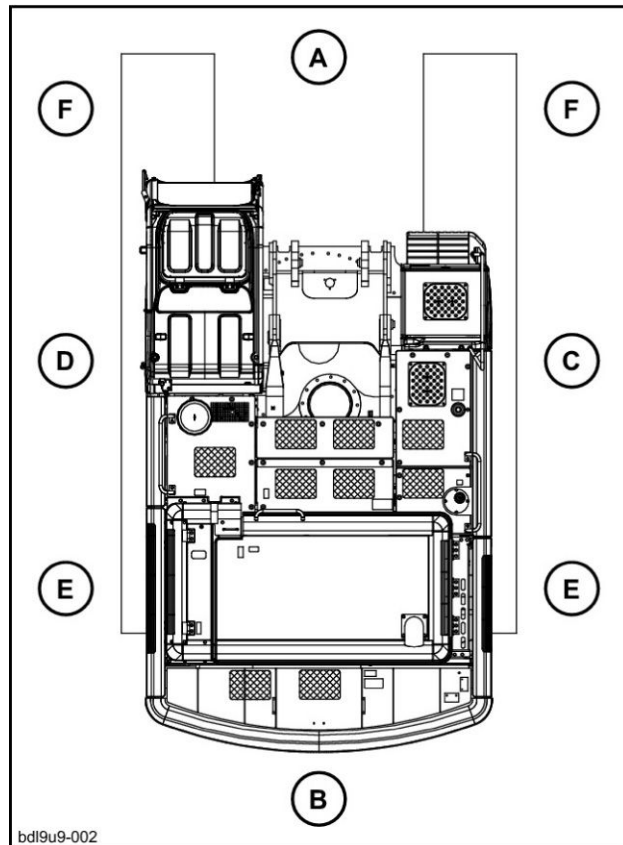

BDL9U9-002 1

Electro-magnetic interference (EMC)

Interference may arise as a result of add-on equipment which may not necessarily meet the required standards.

As such interference can result in serious malfunction of the unit and/or create unsafe situations, you must observe the following:

- The maximum power of emission equipment (radio, telephones, etc.) must not exceed the limits imposed by the national authorities of the country.
- The electro-magnetic field generated by the add-on system should not exceed **24 V/m** at any time and at any location in the proximity of electronic components.
- The add-on equipment must not interfere with the functioning of the on board electronics. Failure to comply with these rules will render the warranty null and void.

Description of the main components

The **CX300C** is a totally hydraulic excavator. It consists of an undercarriage fitted with tracks and a turntable bearing which supports the upperstructure frame. The upperstructure frame supports the attachment, at the front end of the machine, plus the engine, hydraulics and cab. When the operator works the controls, the engine-driven pump delivers hydraulic fluid to the control valves. The control valves distribute the hydraulic fluid to the various cylinders and hydraulic motors employed. A cooling system maintains the hydraulic fluid at normal operating temperature.

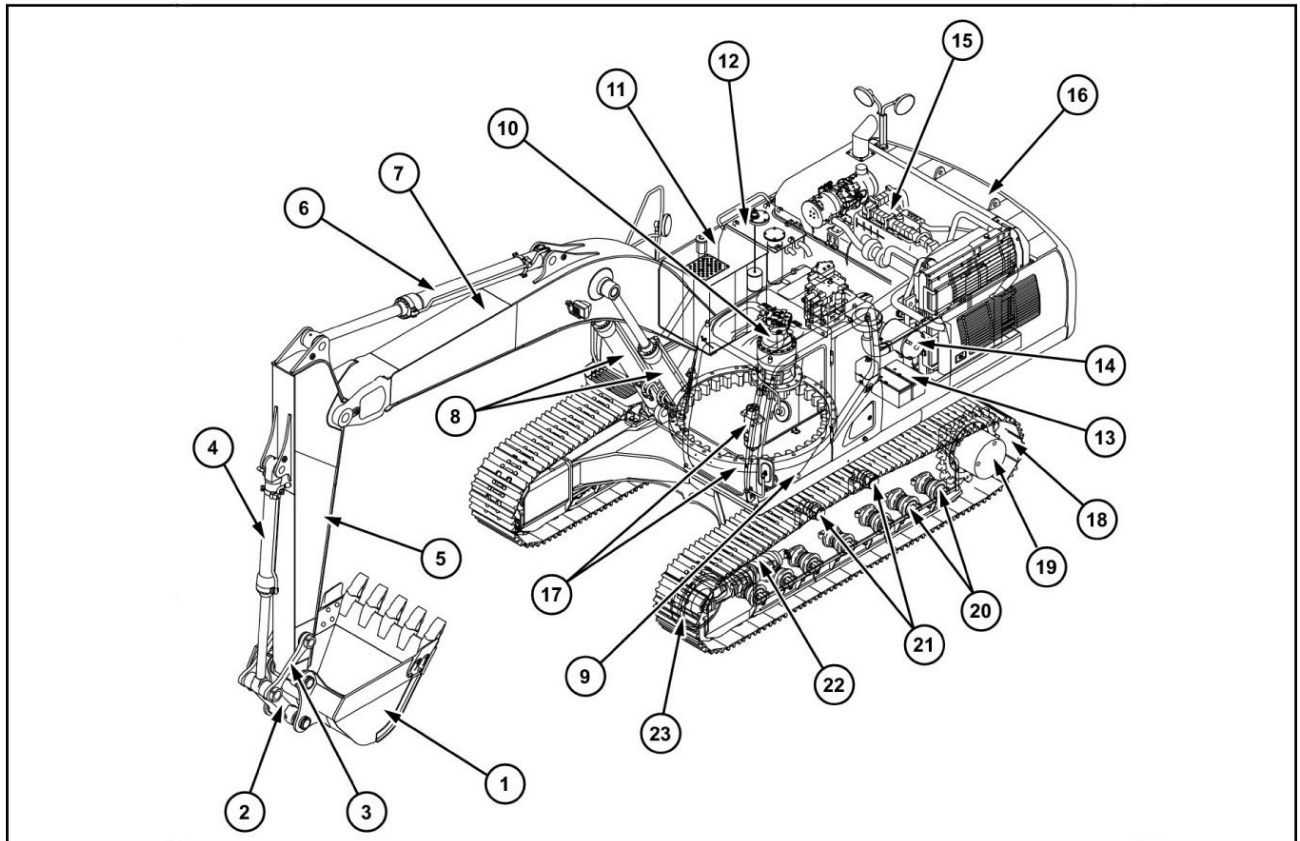

P55RY8-002 1

- | | |
|--------------------------------|------------------------------|
| (1) Backhoe bucket | (13) Batteries |
| (2) Connecting rod | (14) Air filter |
| (3) Yokes | (15) Engine compartment |
| (4) Backhoe bucket cylinder | (16) Counterweight |
| (5) Arm | (17) Swing components |
| (6) Arm cylinder | (18) Tracks |
| (7) Boom | (19) Travel reduction gears |
| (8) Boom cylinders | (20) Lower rollers |
| (9) Cab/Operator's compartment | (21) Upper rollers |
| (10) Swing reduction gear | (22) Tension shock absorbers |
| (11) Fuel tank | (23) Idler wheels |
| (12) Hydraulic reservoir | |

2 - SAFETY INFORMATION

Safety rules

Your safety and that of people around you depends on you. It is essential that you understand this manual for the correct operation, inspection, lubrication and maintenance of this machine.

Read this manual carefully and check that:

- You understand fully the symbols on the controls and the safety signs used in this manual and on the machine.
- You understand fully the speed, stability, braking and steering characteristics of the machine. If you are in any doubt, consult your CASE Dealer.

The safety messages in this manual concern situations which may arise during normal machine operation and servicing. These safety messages also indicate the different ways of coping with these situations. Other safety messages are used throughout the manual to indicate specific dangers.

Whatever type of work is being done (earthmoving, handling, etc.), the safety measures for private or public work-sites are those which conform to current regulations in the country concerned, or the type of operation concerned (for example: mining, quarrying, underground work).

The safety instructions given in this manual are a summary of the basic rules to be respected at all times and do not exempt you from insurance requirements or from abiding by the highway code.

Always keep this manual in the location provided for that purpose (behind the operator's seat). Make sure it is always complete and in good condition. If you wish to obtain extra copies, or copies in languages other than that of the country of use, consult your CASE Dealer.

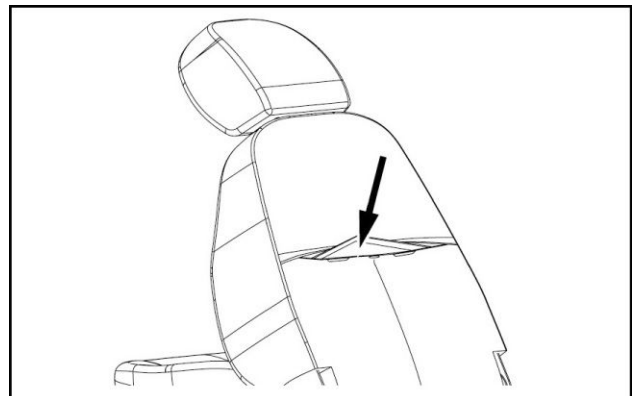

YLN3P-001A 1

BEFORE USING THE MACHINE

1. Avoid loose fitting clothing, loose or uncovered long hair, jewelry or any other items which could get caught up in machinery.
2. Different types of job will require different types of protective equipment. Items such as hard hats, safety shoes, heavy gloves, reflector type jackets, respirators, ear protection and eye protection may be required. Before starting a job, determine what protective equipment will be necessary. Use this equipment at all times.
3. Do not attempt to operate this machine unless you have first read and perfectly understood the safety messages and instructions appearing in this manual.
4. Operating the machine requires full attention and care on the part of the operator can avoid accidents. Get to know the machine's possibilities and limitations and the working space required. There are areas of poor visibility in the working range of the machine. Have someone guide you for all areas where visibility is not perfect.
5. Grease, oil, mud or (in winter) ice on the steps and access handles can cause accidents. Make sure they are kept clean at all times.
6. Every day, inspect the machine to detect any signs of hydraulic fluid leakage. Tighten the connections or replace any defective components as necessary.
7. Remove any obstructions which hinder visibility. Keep the windshield, rear view mirror and windows clean at all times.
8. Make sure the windshield wiper works correctly.
9. Make sure you are perfectly familiar with hand signals in daily use on the worksite to be able to obtain help with tight maneuvers or when carrying out operations where visibility is poor.
10. Before undertaking any travel or working operations during hours of darkness, make sure the lighting and signalling equipment is fully operative.
11. Before any travel operation, make sure that the doors and hoods are properly latched.
12. Check that no tools or other items have been left on the machine (be it on the undercarriage or the upperstructure) or in the operator's compartment.
13. The operator must be alone on the machine at all times. Do not allow anyone to stand on or around the machine.
14. To get in or out of the cab, it is imperative that the upperstructure frame is in line with the undercarriage.
15. When alighting from or getting into the operator's compartment, always face the machine and use the steps and access handles.
16. Be sure you know the position and function of each control. Incorrect operation of the controls can cause serious injuries.
17. Check all controls and safety devices in a safe, open area before starting work.
18. Keep away from dangerous areas such as ditches, overhangs, rocky areas, etc. Make a survey of the work-site and determine the possible dangers before using the machine.
19. Before parking the machine, make sure that the ground is stable. Plan the worksite so that the ground is flat, hard and level.
20. Before moving the machine to work in a new area, walk around to determine all possible causes of accidents there. Holes, obstacles, debris and other danger risks in the working area can cause serious injury.
21. Be ready to meet emergencies. Always carry a first aid kit and if possible, fire extinguisher (not supplied) within easy reach on board. Make sure the fire extinguisher is regularly serviced in conformance with the manufacturer's instructions.
22. Check the fastening of the main components: counterweight, turntable bearing and operator's compartment. In the event of problems, consult your CASE Dealer.
23. Make sure you understand the symbols used on the machine safety decals. Keep the decals clean so that they are perfectly legible at all times.
24. Work out a means of convenient escape from the machine (emergency exit via the windshield or the rear window glass) in the event of the machine turning over or tipping over or the cab door being jammed.
25. Make sure you are perfectly familiar with traffic regulations and special safety equipment requirements before transporting this machine on a public highway.
26. When loading trucks, never swing the load over the truck cab.
27. Before undertaking any travel on the job site, make sure the itinerary to be followed is completely safe. If bridges are to be crossed, make sure they are perfectly capable of supporting the weight of the machine.
28. Always steer around large obstacles such as boulders, big trees, etc.

Quick coupler (optional)

1. It is mandatory for the switch to be in the locked position when operating the machine.
2. Every day, check that the locking bar functions correctly and that it is not fouled by foreign matter. Clean the locking system if necessary.
3. If you are obliged to use the quick coupler with buckets not manufactured by CASE, make sure the diameter of the pins and the width between the bucket lugs meet the dimensions needed to fit the quick coupler (pins, washers, bushings, etc.). Consult your CASE Dealer.

OPERATING THE MACHINE

1. When working on a public highway, use standard traffic signs and take into consideration the working range of the upperstructure and its attachments. Local or national regulations stipulate the number, type and location of reflector strips.
2. Avoid running the engine in a confined space. If there is no alternative, proper ventilation must be provided at all times.
3. Do not allow anyone else on the machine. The passenger could fall or cause an accident.
4. Never operate the working or travel controls unless you are properly seated in the operator's seat with the seat belt correctly fastened.
5. Before starting the engine, check the direction of travel (in forward drive, the reduction gears should be to the rear of the machine).
6. Do not work near overhead high-voltage electric lines without checking beforehand that all necessary measures have been taken to respect the minimum distances:
Less than 57000 volts: **3 m (9.8 ft)**.
More than 57000 volts: **5 m (16.4 ft)**.
7. Study the position of any existing pipelines or conduits before starting work. Electrical cables, gas and water pipes and other underground installations can cause serious injury.
8. Always make allowance for working conditions (sloping or rough ground), the site and weather conditions when driving the machine.
9. Do not allow anyone to stand in the machine working area. Accidental operation of the upperstructure swing control or of an attachment control could cause an accident. Stop all operations until everyone has moved away.
10. Operate all controls gradually to ensure smooth machine operation.
11. Whenever load handling operations are to be carried out, it is imperative to adhere strictly to the instructions given in this manual and local legislation.
12. It is forbidden to use the machine to carry out tasks other than those for which it is intended. Never use the equipment for sweeping the ground to level out rubble or push objects (transversal stress on the attachment).
13. Stop the engine and remove the ignition key when the machine is not in use, even for short periods of time.
14. The working area of the end attachment that is mounted may interfere with the machine. Interference may be caused due to the type of end attachment or installation of parts such as a cab guard. Always maintain a safe margin of distance. (Be careful of tool swing or accidental operations.)
15. To access or exit the operator's compartment, the left-hand control arm must be in the raised position. Never forget this basic requirement.
16. Never leave the operator's compartment while the engine is running.
17. To get in or out of the cab, it is imperative that the upperstructure frame is in line with the undercarriage.
18. Dust, smoke or mist can reduce visibility and cause an accident. Reduce speed or come to a complete halt until visibility has improved.
19. Never jump down from the machine. When alighting from the machine or the upperstructure, always face the machine and use the steps and access handles.
20. In the event of an operating problem or failure, move the machine to a safe place, lower the attachment to the ground, shut down the engine and remove the ignition key. Locate the problem, report it if necessary and take the necessary steps to warn others not to attempt to operate the machine.
21. Before tilting the seat back forward, it is mandatory to raise the armrests to avoid any accidental operation of the control levers.

CAB PROTECTION ROPS, FOPS (optional) and OPG (Operator Protective Guard, optional)

1. Never try to weld or straighten up the protective structure.
2. Do not modify the protective structure in any way. Any modification, such as welding, drilling, cutting, addition of accessories, as well as damage suffered following an impact reduces the protection that it provides. Replace the protective structure if it has suffered an impact and do not attempt to repair it.
3. Incorrect inspection or service work of the protective structure may lead to serious injury. Carry out inspection operations of the protective structure given in this manual. If the protective structure or its components need to be replaced, use only those parts that are listed in the spare parts catalog corresponding to your machine.

QUICK COUPLER (optional)

1. Never place the control switch in the unlocked position when the machine is working.
2. Each time a bucket is installed on the quick coupler, close the bucket and raise the attachment so as to be able to make a visual check that the bucket pin is correctly engaged in the latching hook.
3. The quick coupler modifies the working range of the machine. In certain attachment positions the tool may foul the machine. Always leave a safety distance.
4. Never carry out load handling using the front or rear anchoring points used to install the tool on the quick coupler.
5. Never put your hands inside the quick coupler and never attempt to adjust or repair the quick coupler if the engine is running.

PARKING THE MACHINE

When parking the machine, proceed as follows:

1. Position the machine on flat, level ground, away from soft ground, excavations or poorly shored cavities.
2. Place the upperstructure and the attachment in line with the undercarriage, retract the attachment and dig the bucket into the ground.
3. Stop the engine and remove the ignition key.
4. You must place the function cancellation lever in the central position (safety bar in inward position) before leaving the operator's compartment.
5. Lock the cab door.
6. Make sure that the hoods and doors are properly latched.
7. Check that no part of the machine is encroaching on the highway. If this cannot be avoided, install the necessary regulation signalling equipment.

MAINTENANCE AND ADJUSTMENTS

1. Do not try to service this machine unless you have first read and perfectly understood the safety messages and instructions featuring in this manual.
2. When carrying out service work always wear suitable dress. Avoid loose-fitting clothing.
3. Release pressure completely in the hydraulic system before disconnecting the hydraulic piping. Hydraulic oil escaping under pressure can cause serious injury.
4. Before commencing any work on the machine, place a "Do not operate" tag on the right-hand control arm.
5. Always wear eye protection when using a tool that might project metal particles. Use a hammer with a soft face, such as copper, for installing pins.
6. Badly carried out maintenance or adjustments can cause serious injuries. If you do not understand a ser-

vice or adjustment procedure, consult your CASE Dealer.

7. If the attachment is raised or if the machine moves without an operator, serious injury can result. Before carrying out maintenance on this machine, proceed as follows:
 1. Park the machine on flat, level ground.
 2. Lower the attachment until it is resting on the ground.
 3. Stop the engine and remove the ignition key.
 4. Lock the tracks to prevent any machine movement.
8. Any unauthorized modifications made to this machine can cause serious injury. Do not undertake any modifications without first consulting your CASE Dealer. Any modifications made must be in conformity with the technical specifications of the machine and any current safety legislation requirements.
9. Certain components of the machine are subject to type approval. When replacing such components, it is mandatory to make sure that they conform to regulations. For safety's sake, use genuine CASE parts.
10. Pressurized hydraulic fluid or grease which penetrates the skin can cause serious injury. Take the necessary safety precautions (safety clothing and protection for face and hands) to avoid such risks. Also, before using these products, read the manufacturer's instructions concerning their use. If hydraulic fluid penetrates the skin, call a doctor immediately.
11. Coolant solution is toxic.
Avoid contact with skin, eyes and clothing.
Antidote:
EXTERNAL: rinse thoroughly with water and remove soiled clothes.
INTERNAL: do not induce vomiting. Rinse the mouth out with water. Seek medical advice.
EYES: rinse thoroughly with water and seek medical advice.
12. The pressure in the track tension cylinders is high. Follow the procedure described in this manual carefully for increasing or reducing track tension.
13. When carrying out a welding operation on the undercarriage or upperstructure carriage as authorized by the manufacturer and in accordance with his instructions, disconnect the batteries, disconnect the alternator B+ and D+ terminal wires and connect the welding apparatus earth cable to the component on which the welding operation is to be performed. Never connect the welding apparatus to the undercarriage when welding on the upperstructure (or vice-versa). Never connect the welding apparatus earth to a component of the hydraulic system.
14. When using compressed air, take the necessary precautions to protect your face.
15. Clean the machine regularly. Accumulations of grease, dirt and debris can cause injuries or damage the machine.