

**CX290  
Excavator**

Operator's Manual

6-31380





*THIS SAFETY ALERT SYMBOL INDICATES IMPORTANT SAFETY MESSAGES IN THIS MANUAL. WHEN YOU SEE THIS SYMBOL, CAREFULLY READ THE MESSAGE THAT FOLLOWS AND BE ALERT TO THE POSSIBILITY OF DEATH OR SERIOUS INJURY*

M171D

Safety Decals on this machine use the words **Danger, Warning, or Caution**, which are defined as follows:

- **DANGER:** Indicates an immediate hazardous situation that, if not avoided, will result in death or serious injury. The color associated with Danger is RED.
- **WARNING:** Indicates a potentially hazardous situation that, if not avoided, could result in death or serious injury. The color associated with Warning is ORANGE.
- **CAUTION:** Indicates a potentially hazardous situation which, if not avoided, may result in minor or moderate injury. It may also be used to alert against unsafe practices. The color associated with Caution is YELLOW.



## WARNING

IMPROPER OPERATION OF THIS MACHINE CAN CAUSE DEATH OR SERIOUS INJURY. BEFORE USING THIS MACHINE, MAKE CERTAIN THAT EVERY OPERATOR:

- Is instructed in safe and proper use of the machine.
- Reads and understands the Manual(s) pertaining to the machine.
- Reads and understands ALL Safety Decals on the machine.
- Clears the area of other persons.
- Learns and practices safe use of machine controls in a safe, clear area before operating this machine on a job site.

It is your responsibility to observe pertinent laws and regulations and follow Case Corporation instructions on machine operation and maintenance.

# TABLE OF CONTENTS

<b>TO THE OWNER</b> .....	1
CX290 EXCAVATOR .....	1
TO THE OWNER (CONTINUED) .....	2
RIGHT,LEFT,FRONT AND REAR OF THE MACHINE .....	3
<b>IDENTIFICATION NUMBERS</b> .....	5
TYPE, SERIAL NUMBER AND YEAR OF MANUFACTURE .....	5
MACHINE COMPONENTS .....	6
KEY TO MAIN COMPONENTS .....	6
<b>SAFETY RULES</b> .....	7
UTILITY SAFETY .....	8
PERSONAL SAFETY .....	9
BEFORE OPERATION .....	10
MACHINE OPERATION .....	11
BURN PREVENTION .....	12
FIRE EXTINGUISHER .....	13
FIRE OR EXPLOSION PREVENTION .....	14
MAINTENANCE .....	15
BEFORE USING THE MACHINE .....	17
SAFETY AREA .....	20
PARKING THE MACHINE .....	20
MAINTENANCE AND ADJUSTMENTS .....	21
DECALS .....	23
HAND SIGNALS .....	34
<b>INSTRUMENTS/CONTROLS</b> .....	39
CAB DOOR .....	39
STEPS AND ACCESS HANDLES .....	40
OPERATOR'S COMPARTMENT CONTROLS .....	42
LOCATION OF CONTROLS AND ASSOCIATED COMPONENTS .....	42
RIGHT-HAND CONTROL ARM .....	45
LEFT-HAND CONTROL ARM .....	46
SYSTEMS DISPLAY AND CONTROL PANEL .....	48-56
ANTI-THEFT DEVICE .....	57
ARM AND UPPERSTRUCTURE SWING .....	60
LEFT-HAND CONTROL LEVER .....	60
BOOM AND BUCKET .....	61
RIGHT-HAND CONTROL LEVER .....	61
OPTIONAL CONTROL PATTERN .....	62
ARM AND UPPERSTRUCTURE SWING LEFT-HAND CONTROL LEVER .....	62
OPTIONAL CONTROL PATTERN .....	63
BOOM AND BUCKET RIGHT-HAND CONTROL LEVER .....	63
TRAVEL CONTROL LEVERS AND PEDALS .....	64
OPERATOR'S SEAT .....	73
WINDSHIELD .....	77

TRIM THIS EDGE

TRIM THIS EDGE

RIGHT PAGE (Chapter First Page)

TRIM THIS EDGE

LOWER FRONT WINDOW .....	79
REAR WINDOW AND EMERGENCY EXIT .....	80
FUEL TANK .....	82
REAR VIEW MIRRORS .....	83
SIDE DOORS .....	84
ENGINE HOOD .....	85
LOWER PANELS .....	87
WINDSHIELD WASHER RESERVOIR .....	87
BUCKET LIFTING EYE .....	88
TOWING HOLES .....	89
CYLINDER MOUNTED LOAD HOLDING CONTROL DEVICES .....	90
TOOL SUPPLY VALVES (OPTIONAL) .....	91
<b>OPERATING INSTRUCTIONS</b> .....	<b>93</b>
BEFORE OPERATING THE MACHINE .....	93
MACHINE OPERATION .....	94
BREAK-IN PERIOD .....	96
ANTI- VANDAL GUARD .....	97
STARTING THE ENGINE .....	99
BRINGING THE MACHINE UP TO OPERATING TEMPERATURE .....	102
ENGINE OPERATION .....	103
OPERATING THE MACHINE IN COLD WEATHER .....	104
OPERATING THE MACHINE IN HOT WEATHER .....	104
STOPPING THE ENGINE .....	106
MACHINE OPERATION .....	107
MACHINE TRAVEL .....	109
LIFTING THE MACHINE .....	112
LIFTING LOADS WITH THE MACHINE .....	112
OPERATING THE MACHINE IN WATER .....	114
OPERATING THE MACHINE ON SLOPING GROUND .....	114
OPERATING THE BUCKET .....	115
PARKING THE MACHINE .....	116
AUXILIARY HYDRAULIC (OPTIONAL) .....	119
TRANSPORTING THE MACHINE .....	124
<b>LUBRICATION</b> .....	<b>129</b>
FLUIDS AND LUBRICANTS .....	129
HOURLY METER .....	130
DAILY INSPECTION .....	130
INTERVALS .....	132
ENGINE OIL .....	134
FLUID AND LUBRICANT CAPACITIES AND SPECIFICATIONS .....	136
HYDRAULIC FLUID CHART .....	137
GREASE POINTS .....	138
GREASING THE TURNTABLE TEETH .....	141
GREASING THE SWING REDUCTION GEAR .....	141
FLUID LEVELS .....	142

II

TRIM THIS EDGE

LEFT PAGE

Bur 6-31380na

ENGINE .....	144
COOLING SYSTEM .....	147
FUEL SYSTEM .....	150
RELEASING PRESSURE IN THE HYDRAULIC SYSTEM .....	152
HYDRAULIC SYSTEM .....	154
RETURN FILTER .....	164
AIR FILTER .....	165
SERVICE SPECIFICATIONS .....	165
SWING REDUCTION GEAR .....	169
TRAVEL REDUCTION GEARS .....	171
<b>ADJUSTMENT/MAINTENANCE .....</b>	<b>173</b>
TRACK ROLLERS AND IDLER WHEELS .....	177
DRIVE BELT .....	178
FUEL TANK FILTER .....	179
INSPECTING AND CLEANING THE MACHINE .....	179
CHECKING FOR CYLINDER LEAKAGE .....	180
PLASTIC AND RESIN PARTS .....	180
REPLACING A BUCKET .....	181
WELDING ON THE MACHINE .....	183
FIRE EXTINGUISHER (OPTIONAL) .....	183
AIR CONDITIONING .....	184
TORQUE SPECIFICATIONS .....	187
<b>ELECTRICAL .....</b>	<b>189</b>
BATTERIES .....	191
CONNECTING BOOSTER BATTERIES .....	193
REPLACING A BULB .....	194
<b>MACHINE STORAGE .....</b>	<b>197</b>
<b>SPECIFICATIONS .....</b>	<b>199</b>
ENGINE .....	199
HYDRAULIC SYSTEM .....	200
WEIGHTS .....	201
DIMENSIONS .....	202
WORKING RANGE .....	205
LIFTING CAPACITIES .....	208
<b>INDEX .....</b>	<b>213</b>
<b>AFTER DELIVERY CHECK .....</b>	<b>215</b>
AFTER DELIVERY CHECK .....	217

TRIM THIS EDGE

TRIM THIS EDGE

IV

TRIM THIS EDGE

LEFT PAGE

Bur 6-31380na

# TO THE OWNER

## CX290 EXCAVATOR



TRIM THIS EDGE

BD01M020

The **CX290** consists of an undercarriage fitted with tracks and a turntable bearing which supports the upperstructure frame. The upperstructure frame supports the attachment, at the front end of the machine, plus the engine, hydraulics and cab. When the operator works the controls, the engine-driven variable flow pump delivers hydraulic fluid under pressure to the control valves. The control valves distribute the hydraulic fluid to the various cylinders and hydraulic motors employed. A cooling system and oil cooler keep the fluid temperature down to normal working temperature.

Your machine has been designed and built to the highest standards of quality. It conforms to all current safety regulations. See "Official documents". However, the risk of accidents can never be completely excluded. That is why it is essential to observe elementary safety rules and precautions.

Read this manual carefully, paying particular attention to the instructions concerning safety, operation and maintenance so as to avoid the risk of injury while operating or servicing the machine.

Use this manual as a guide. Your machine will remain a reliable working tool provided it is kept in good working condition and serviced properly.

1

TRIM THIS EDGE

RIGHT PAGE (Section First Page)

6-31380na

## TO THE OWNER (CONTINUED)

The standard attachments and equipment available for use with this machine are intended for general earth moving purposes, material rehandling, ditch cleaning, etc. If the machine is to be used for handling loads, (tubing, concrete pipe sections, shoring material, etc.), make sure the machine is suitably equipped for this type of work. For this type of application, the machine must be equipped with safety valves, an overload indicator, a load handling chart corresponding to the type of machine and its attachment and a load fixing point. All legal requirements must also be strictly observed.

Do not use this machine for any application or purpose other than those described in this manual. If the machine is to be used for work involving the use of special attachments, accessories or equipment, consult your CASE Dealer in order to make sure that any adaptations or modifications made are in keeping with the machine's technical specifications and with prevailing safety requirements.

Any modification or adaptation which is not approved by the manufacturer may invalidate the machine's initial conformity with safety requirements.

The machine must undergo regular inspections, the frequency of which varies according to the type of use. Consult your CASE Dealer.

Before permitting a new operator on this machine, make sure:

1. That the operator has received the necessary training on how to operate the machine correctly and safely.
2. That the operator has read and understood the instructions given in this manual.

Always keep this manual in the operator's compartment (in the seat back, behind the operator's seat). Make sure it is always complete and in good condition. If you wish to obtain additional manuals, or manuals in another language, consult your CASE Dealer.

Your CASE Dealer is at your disposal for any further information. He will also provide any after-sales service you may require, and genuine CASE spare parts, your guarantee of quality and match.

TRIM THIS EDGE



## RIGHT,LEFT,FRONT AND REAR OF THE MACHINE

The terms "Right", "Left", "Front" and "Rear" are used in this manual to indicate the sides as they are seen from the operator's seat when the cab is over the idler wheels.

The illustration below shows the machine in normal TRAVEL position. In normal TRAVEL position, the cab is over the idler wheels. The travel reduction gears are at the rear of the upper-structure.

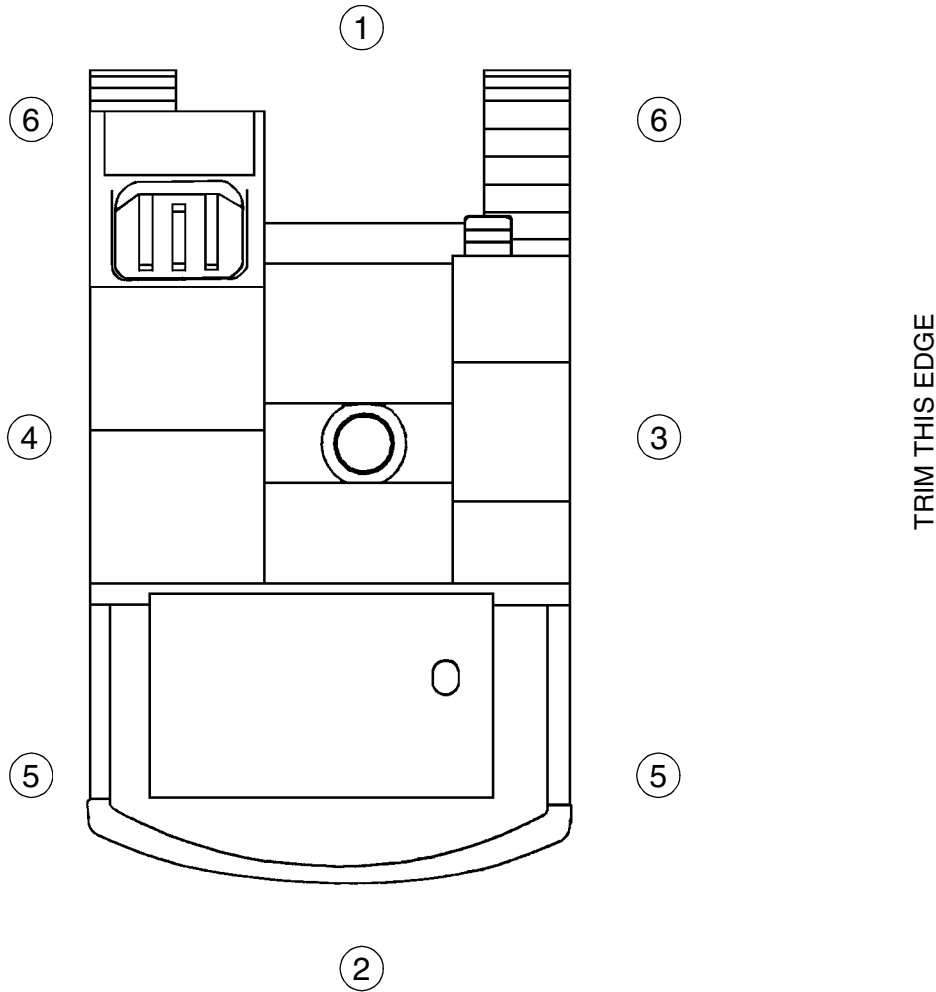

- 1. FRONT
- 2. REAR
- 3. RIGHT-HAND SIDE
- 4. LEFT-HAND SIDE
- 5. TRAVEL REDUCTION GEARS
- 6. IDLER WHEELS

CS99A820

TRIM THIS EDGE

RIGHT PAGE

Bur 6-31380na

**NOTES**

TRIM THIS EDGE

4

TRIM THIS EDGE

LEFT PAGE

6-31380na

# IDENTIFICATION NUMBERS

## TYPE, SERIAL NUMBER AND YEAR OF MANUFACTURE

When ordering parts, obtaining information or assistance, always supply your CASE Dealer with the type and serial number of your machine or accessories.

Write the following in the spaces below: The type, serial number and year of manufacture of your machine, accessories and the serial numbers of the various hydraulic and mechanical components.

### Machine

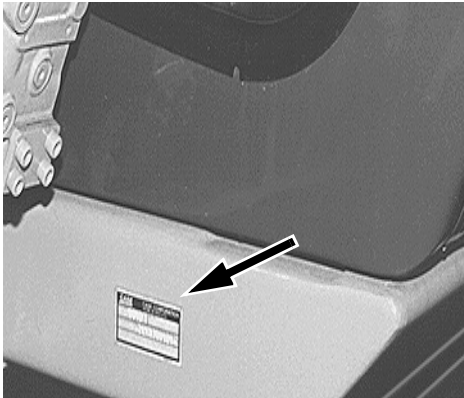

CP98N006

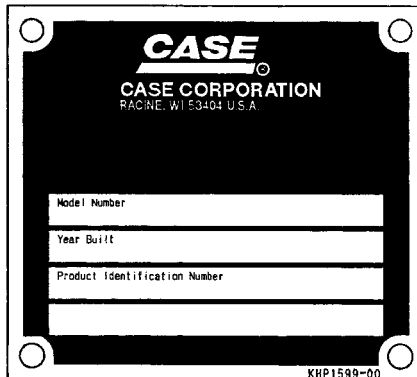

KHP1540-00 BC00M110

TRIM THIS EDGE

1. (1) Type.....
2. (2) Serial number.....
3. (3) Year of build .....

### Engine

Make and type.....  
Serial number.....

### Component serial numbers

Hydraulic pump .....

Swing reduction gear .....

Travel reduction gears.....

Travel control valve .....

Attachment control valve .....

Swing control valve .....

TRIM THIS EDGE

RIGHT PAGE (Section First Page)

## MACHINE COMPONENTS

TRIM THIS EDGE

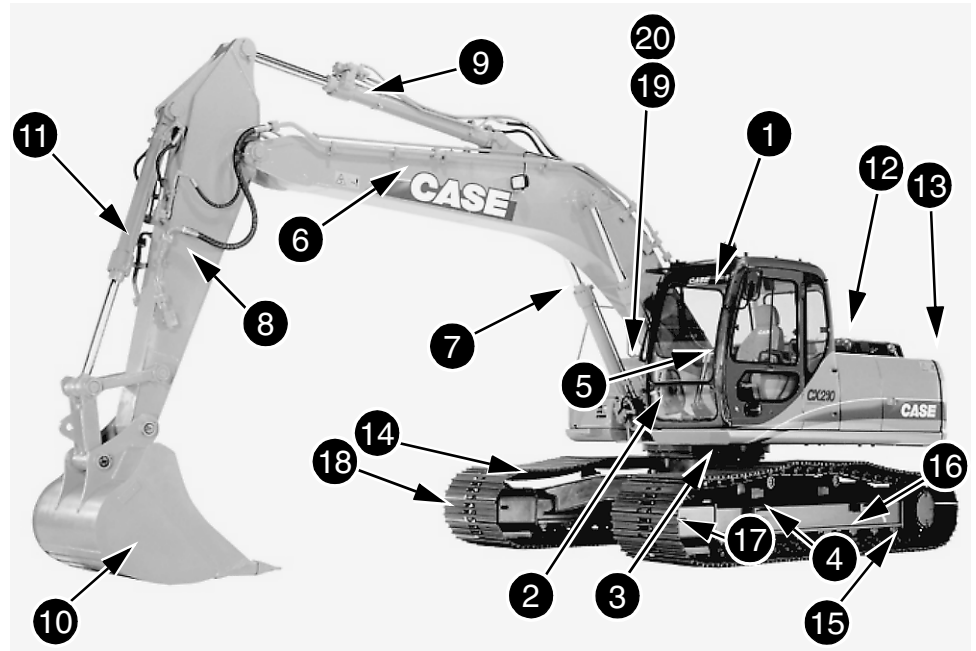

BD01M020

## KEY TO MAIN COMPONENTS

- |                               |                            |
|-------------------------------|----------------------------|
| 1. Cab/Operator's compartment | 11. Bucket cylinder        |
| 2. Upperstructure             | 12. Engine compartment     |
| 3. Undercarriage              | 13. Counterweight          |
| 4. Steps                      | 14. Upper Rollers          |
| 5. Access handles             | 15. Travel reduction gears |
| 6. Boom                       | 16. Lower Rollers          |
| 7. Boom cylinders             | 17. Idler wheels           |
| 8. Arm                        | 18. Tracks                 |
| 9. Arm Cylinder               | 19. Hydraulic reservoir    |
| 10. Bucket                    | 20. Fuel Tank              |

TRIM THIS EDGE

LEFT PAGE

6-31380na

# ⚠ SAFETY RULES ⚠

Most accidents involving machine operation and maintenance can be avoided by following basic rules and precautions. Read and understand all the safety messages in this manual, the EMI Safety Manual, and the safety decals on the machine before you operate or service the machine. See your Authorized Case dealer if you have questions.



CD00E001

## 1. OPERATOR'S MANUAL STORAGE

Safety messages in this section point out situations which can be encountered during the normal operation and maintenance of your machine. These safety messages also give possible ways of dealing with these conditions.

Additional safety messages appear in the manual to indicate specific safety hazards.

READ THIS MANUAL COMPLETELY and make sure you understand the characteristics of speed, stability, steering, and operation of this machine.

Do not remove this manual or the safety manual from this machine. See your Case dealer for additional manuals. Also see the inside of the rear cover of this manual for detailed information for ordering manuals.

The safety information given in this manual does not replace safety codes, insurance regulations, or federal, state/provincial, or local laws. Make sure your machine has the correct equipment according to these rules or laws.

**IMPORTANT:** *The safety messages in this section point out situations which can happen during the normal operation and maintenance of your machine. These safety messages also give possible ways of dealing with these conditions.*

Additional safety messages are used in the text of the manual to show specific safety hazards.

TRIM THIS EDGE



**WARNING:** *This safety alert symbol indicates important safety messages in this manual. When you see this symbol, carefully read the message that follows and be alert to the possibility of personal injury or death.*

M171B

TRIM THIS EDGE

RIGHT PAGE (Section First Page)

Bur 6-31380na

**⚠️ UTILITY SAFETY ⚠️**

Safety precaution **MUST** be followed when working near buried Utility Lines.

During operation it is likely that you will be working around or near buried utility lines which may include, but are not limited to:

- Electrical Power Line
- Gas Line
- Water Line
- Communication Line - Telephone or Cable Television

**Before beginning any trenching, or other construction work it is your responsibility to be aware of all such utility lines buried in the area of your project and to avoid them.**

ALWAYS have all local utility companies mark the location of their lines.

In U.S.A. and Canada call one of many "One Call System Director" services. If you do not know the local number, call the national number (U.S.A. and Canada only): 1-888-258-0808.

**Check with local authorities for laws, regulations and/or strict penalties requiring you to locate and avoid existing utilities.**

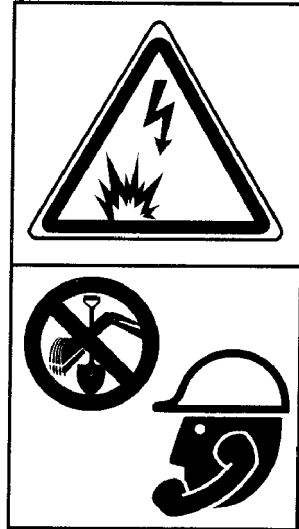

**CALL ALL LOCAL UTILITY COMPANIES BEFORE YOU DO ANY TRENCHING** RH99G001

Know the utility color code (U.S.A. and Canada):

- Electric ..... Red
- Gas, Oil, or Petroleum..... Yellow
- Communication, Telephone, Television ..... Orange
- Water..... Blue
- Sewer..... Green/Brown
- Proposed Excavation ..... White
- Surveying..... Pink
- Reclaimed Water and Slurry ..... Purple

After locating the utility lines, carefully dig a hole by hand and/or automatic vacuum equipment to the utility line to verify the location and depth of the line.

TRIM THIS EDGE

TRIM THIS EDGE



LEFT PAGE

## PERSONAL SAFETY

Safety Decals on this machine use the words **Danger, Warning or Caution**, which are defined as follows:

- **DANGER:** Indicates an immediate hazardous situation which, if not avoided, will result in death or serious injury. The color associated with Danger is RED.
- **WARNING:** Indicates a potentially hazardous situation which, if not avoided will result in serious injury. The color associated with Warning is ORANGE.
- **CAUTION:** Indicates a potentially hazardous situation which, if not avoided, may result in minor or moderate injury. It may also be used to alert against unsafe practices. The color associated with Caution is YELLOW.

ISO two panel pictorial symbol decals are defined as follows:

- The first panel indicates the nature of the hazard.
- The second panel indicates the appropriate avoidance of the hazard.
- Background color is YELLOW.
- Prohibition symbols such as   and  if used are RED.

TRIM THIS EDGE

 **BEFORE OPERATION** 

- Avoid loose fitting clothing, loose or uncovered long hair, and jewelry.
- Different jobs will require different protective equipment. Items such as hard hats, protective shoes, heavy gloves, reflector type vests, respirators, ear protection, and eye protection can be required. Before you start the job, determine what protective equipment is required. Use this equipment at all times.
- Be prepared for emergencies. Always have a first aid kit and a working fire extinguisher with you and know how to use each.
- Know the hand signals used on your job. Follow the instructions of the flagman, signs, etc.
- Check that all doors, guards, and covers are installed correctly or closed.
- Foreign material or grease on the steps and hand rails can cause an accident. Keep the steps and hand rails clean.
- To avoid falling, always face the machine and maintain three point support while using the steps and grab handles when getting on or getting off. Do not rush.
- Remove all loose objects from the cab. Loose objects can jam controls and cause accidents.
- Before you start each day, walk around the machine and check for oil or fluid leaks. Replace all broken or missing parts and do the required lubrication and maintenance as shown in this manual. Clean all trash and debris from the machine, especially from the engine area.

TRIM THIS EDGE

TRIM THIS EDGE

LEFT PAGE

Bur 6-31380na



- Make sure all persons are away from the machine before you start the engine.
- Before you start the engine, always fasten the seat belt.
- Before you operate at night, check that all lamps illuminate.
- Make sure that all windows are clean and that the windshield wipers work correctly.

## ⚠ MACHINERY OPERATION ⚠

- Check all controls in a clear area and make sure the machine is operating correctly.
- Do not allow other persons to ride on the machine. Other persons can fall or can cause an accident. This is a one person machine with one operator's seat.
- Dust, fog, smoke, etc., can decrease your vision and cause an accident. Stop the machine or decrease the speed until you can see everything around you in the work area. Make sure the machine lamps are ON.
- Contact with high voltage power lines, underground cables, etc., can cause serious injury or death from electrocution.
- Before you drive or operate in an area with high voltage lines, cables, or a power station, tell the power or utility company what you are going to do. You **MUST HAVE THE POWER DISCONNECTED OR KEEP A SAFE WORKING DISTANCE** from the lines, cables, or powerstation. Keep all parts of the machine at least 4.6 m (15 feet) away from the power source. You must also know any federal, state/provincial, or local safety codes or regulations that apply to the job site.
- If a part of the machine touches high voltage power:
  - Warn other workers **NOT TO TOUCH THE MACHINE** and to stay away from the machine.
  - If you can break contact, reverse the operation that caused contact with the high voltage power, and move the machine away from the danger area. If you cannot break contact, stay in the machine until the utility company de-energizes the line and tells you that the power is off.
  - If you have extreme conditions, such as a fire, etc., and you are forced to leave the machine, do not step off the machine. Jump as far from the machine as possible with your feet together and do not touch the ground with your hands.
  - Then, hop away with your feet together until you are a safe distance from the machine and the electrical current. Do not take large steps. Because of the voltage differential across the ground, one foot can be in a higher voltage area than the other foot. This difference can kill you.
  - Do not operate the machine if you do not feel well. This can be dangerous for you and for the people around you.
  - You must make a judgment if weather, road, or earth conditions will permit safe operation on a hill, ramp, or rough ground.

TRIM THIS EDGE

- Stay away from hazardous areas such as ditches, overhangs, etc. Walk around the work area before you start and look for hazards.
- Be alert and always know the location of all workers in your area. Keep all other persons completely away from your machine. Injury or death can result if you do not follow these instructions.
- Operate the machine within the specified capacities and limits. Lifting capacities, digging depths, etc, are shown in the Specifications section of this manual.
- Operate the machine controls from the operators seat only.
- Digging through underground cables, pipes, lines, etc., can cause injury or death. Learn the location of all underground hazards before you operate your machine in any area.
- When working in areas where traffic is heavy always have a person direct the traffic and direct other persons for you. Have guard rails, warning signs, etc., as required for your job.
- Stop operating the machine if a malfunction occurs. Watch the indicator and warning lamps in the machine. Listen and smell for things that are not normal on your machine.
- Drive around large objects such as large rocks or trees.

TRIM THIS EDGE

### **BURN PREVENTION**

- Batteries contain sulfuric acid which cause severe burns. Avoid contact with skin, eyes, or clothing. Antidote - EXTERNAL - Flush with water. INTERNAL - Drink large quantities of water or milk. DO NOT induce vomiting. Seek medical attention immediately. EYES - Flush with water for 15 minutes and seek medical attention immediately. Keep sparks, flame, cigars and cigarettes away. **BATTERIES PRODUCE EXPLOSIVE GASES.** Ventilate when charging or using in enclosed area. Always wear eye protection when working with new batteries. Wash hands after handling. **KEEP OUT OF REACH OF CHILDREN.**
- When the battery electrolyte is frozen, the battery can explode if, (1) you try to charge the battery, or (2) you try to jump start and run the engine. To prevent the battery electrolyte from freezing, keep the battery at full charge. If you do not follow these instructions, you or others in the area can be injured.
- Hot coolant can spray out if the radiator cap is removed too quickly. To remove the radiator cap, let the cooling system cool, turn the cap to the first notch, wait until the pressure is released, then remove the cap.

 **FIRE EXTINGUISHER** 

It is recommended that you have a fire extinguisher on your machine. Check with your Case dealer for availability.

A dry chemical fire extinguisher is approved for Class A, B, and C type fires.

TRIM THIS EDGE

## FIRE OR EXPLOSION PREVENTION

- Sparks or flame can cause the hydrogen gas in a battery to explode. To prevent an explosion, do the following:
  1. When disconnecting the battery cables, disconnect the negative (-) cable first; when connecting the battery cables, connect the negative (-) cable last.
  2. Do not short circuit the battery posts with metal items.
  3. Do not weld, grind, or smoke near a battery. Keep open flame away from the battery.
- Sparks from the electrical system or engine exhaust can cause an explosion or fire. Before you operate this machine in an area with flammable dust or vapors, use good ventilation to remove the flammable dust or vapors before you start.
- Engine fuel can cause an explosion or fire. Do not fill the fuel tank while the engine is running.
- DO NOT smoke while refueling the machine.
- Use nonflammable cleaning solvent to clean parts.
- A fire can cause injury or death. Always have a fire extinguisher near or on the machine. Make sure the fire extinguisher is serviced according to the manufacturer's instructions.
- If a fire extinguisher has been used, always recharge or replace the fire extinguisher before operating the machine.
- Remove all trash or debris from the machine as required. Especially check the engine area and exhaust system.
- If the machine has an oil, fuel, or hydraulic leak, always repair the leak and clean the area before operating.
- Keep the cooling system clean and maintain the correct coolant level.
- Make sure that you do not store oily rags or other flammable materials on the machine.
- To avoid damage to the engine, and personal injury do not use starting fluids.
- Before welding or using a torch on the machine, clean the area to be repaired.
- Check the electrical system for loose connections or frayed insulation. Repair or replace the loose or damaged parts.

TRIM THIS EDGE

TRIM THIS EDGE

LEFT PAGE

Bur 6-31380na