



OPERATOR'S MANUAL

EXCAVATOR

CX225 TIER 3



READ, UNDERSTAND, AND FOLLOW ALL SAFETY PRECAUTIONS AND INSTRUCTIONS FOUND IN THIS MANUAL BEFORE OPERATING THE MACHINE.

Bur • Issued 01Feb 08

Printed in U.S.A. • Book/Form Number 87490340 NA

Copyright © 2007. CNH America, LLC. All Rights Reserved.

CNH America, LLC reserves the right to make improvements in design or changes in specifications at any time without incurring any obligation to install them on units previously sold.

All data given in this publication is subject to production variations. Dimensions and weights are only approximate. Illustrations do not necessarily show products in standard condition. For exact information about any particular product, please consult your Dealer



REVISION HISTORY			
Issue	Issue Date	Applicable Machines	Remarks
First Edition	01Feb 08	CX225 Tier 3 Excavator	87490340 NA



THIS SAFETY ALERT SYMBOL INDICATES IMPORTANT SAFETY MESSAGES IN THIS MANUAL. WHEN YOU SEE THIS SYMBOL, CAREFULLY READ THE MESSAGE THAT FOLLOWS AND BE ALERT TO THE POSSIBILITY OF DEATH OR SERIOUS INJURY.

Safety Decals on this machine use the words Danger, Warning, or Caution, which are defined as follows:

- **DANGER:** Indicates an immediate hazardous situation that, if not avoided, will result in death or serious injury. The color associated with Danger is RED.
 - **WARNING:** Indicates a potentially hazardous situation that, if not avoided, could result in death or serious injury. The color associated with Warning is ORANGE.
 - **CAUTION:** Indicates a potentially hazardous situation which, if not avoided, may result in minor or moderate injury. It may also be used to alert against unsafe practices. The color associated with Caution is YELLOW.
- If Safety Decals on this machine are ISO two panel Pictorial, decals are defined as follows:

- The first panel indicates the nature of the hazard.
- The second panel indicates the appropriate avoidance of the hazard.
- Background color is YELLOW
- Prohibition symbols such as , , and  if used, are RED.

WARNING

IMPROPER OPERATION OF THIS MACHINE CAN CAUSE DEATH OR SERIOUS INJURY. BEFORE USING THIS MACHINE, MAKE CERTAIN THAT EVERY OPERATOR:

- ② Is instructed in safe and proper use of the machine.
- ② Reads and understands the Manual(s) pertaining to the machine.
- ② Reads and understands ALL Safety Decals on the machine.
- ② Clears the area of other persons.
- ② Learns and practices safe use of machine controls in a safe, clear area before operating this machine on a job site.

It is your responsibility to observe pertinent laws and regulations and follow instructions on machine operation and maintenance.

CALIFORNIA PROPOSITION 65 WARNING

Diesel engine exhaust and some of its constituents are known to the State of California to cause cancer, birth defects, and other reproductive harm.

Battery post, terminals and related accessories contain lead and lead compounds. Wash hands after handling.

TECHNICAL MANUALS

Manuals are available from your Dealer for the operation, service, and repair of your machine.

Contact your Dealer for assistance in obtaining the manuals for your machine. Your Dealer can expedite your order for Operator's Manuals, Parts Catalogs, Service Manuals, and maintenance records.

Always give the Machine Name, Model, and P. I. N. (Product Identification Number) or S. N. (Serial Number) of your machine so your Dealer can provide the correct manuals for your machine.

To the Owner

Your machine has been designed and built to the highest standards of quality. It conforms to all current safety regulations. See "Official documents". However, the risk of accidents can never be completely excluded. That is why it is essential to observe elementary safety rules and precautions.

Read this manual carefully, paying particular attention to the instructions concerning safety, operation and maintenance so as to avoid the risk of injury while operating or servicing the machine.

Use this manual as a guide. Your machine will remain a reliable working tool provided it is kept in good working condition and serviced properly.

The standard attachments and equipment available for use with this machine are intended for general earth-moving purposes, material rehandling, boring, ditch cleaning, etc. If the machine is to be used for handling loads, (concrete pipe sections, shoring material, etc.), make sure the machine is suitably equipped for this type of work. For this type of application, the machine must be equipped with safety valves, an overload indicator, a load handling chart corresponding to the type of machine and its attachment and a load fixing point. All legal requirements must also be strictly observed.

Do not use this machine for any application or purpose other than those described in this manual. If the machine is to be used for work involving the use of special attachments, accessories or equipment, consult your CASE Dealer in order to make sure that any adaptations or modifications made are in keeping with the machine's technical specifications and with prevailing safety requirements.

Any modification or adaptation which is not approved by the manufacturer may invalidate the machine's initial conformity with safety requirements.

The machine must undergo regular inspections, the frequency of which varies according to the type of use. Consult your CASE Dealer.

Before permitting a new operator on this machine, make sure:

1. That the operator has received the necessary training on how to operate the machine correctly and safely in one of our training centers or from an approved organization.
2. That the operator has read and understood the instructions given in this manual.

Always keep this manual in the operator's compartment (in the seat back, behind the operator's seat). Make sure it is always complete and in good condition. If you wish to obtain additional manuals, or manuals in another language, consult your CASE Dealer.

Your CASE Dealer is at your disposal for any further information. He will also provide any after-sales service you may require, and genuine CASE spare parts, your guarantee of quality and match.

Safety Labels

RIGHT, LEFT, FRONT AND REAR OF THE MACHINE

The terms “Right”, “Left”, “Front” and “Rear” are used in this manual to indicate the sides as they are seen from the operator’s seat when the cab is over the idler wheels.

The illustration below shows the machine in normal TRAVEL position. In normal TRAVEL position, the cab is over the idler wheels. The travel reduction gears are at the rear of the upperstructure.

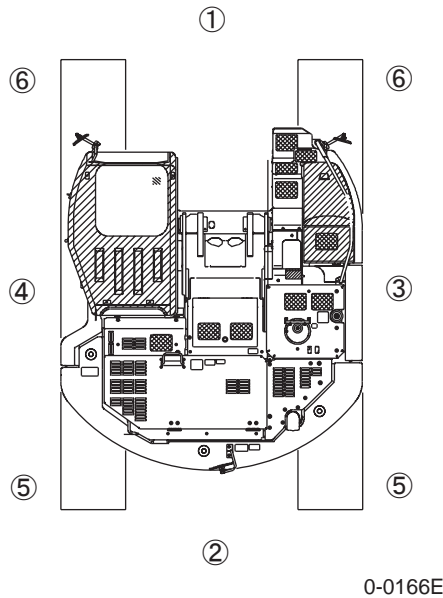

- 0-0166E
- | | |
|-------------------|--------------------------|
| ① FRONT | ④ LEFT-HAND SIDE |
| ② REAR | ⑤ TRAVEL REDUCTION GEARS |
| ③ RIGHT-HAND SIDE | ⑥ IDLER WHEELS |

Break-in

This product is shipped after full inspections and conditioning, however, extremely overloaded usage at the initial stage could lead the reduction in performance and life. Therefore, approx. initial 100 hours (indicated hours on the service meter) break-in is necessary.

Break-in should be conducted paying attention to the following points:

- Try to keep idling and warming for 5 minutes after starting the engine.
- Avoid operation under heavy load or at high speeds.
- Avoid any sudden start, acceleration or unnecessary sudden stop and quick turn.

Specified Work

This product is designed to use mainly in the following work:

- Excavation
- Land grading work
- Trenching work
- Loading work
- Demolition (Demolition specification vehicle only)

For Safe Driving

IMPORTANT:

Remove the protective (rust preventative) aluminum cover wrapped around the cylinder rods immediately after receiving the machine. If the machine is left with the covers on, water can collect on the inside of the cover, which will be the cause for rust to develop on the cylinder rod.

In the case of transportation by sea, sea water salt adheres to the machine making rust easier to develop. Immediately follow the measures below after receiving a machine that has been transported by sea. If the measures are not taken, the machine will develop rust easily.

1. Confirm that there are no salt deposits on the machine exterior. When salt deposits are suspected, wash the entire machine with water.

⚠ CAUTION

Do not use high pressure cleaning water directly on the alternator, battery and other electrical parts or wiring.

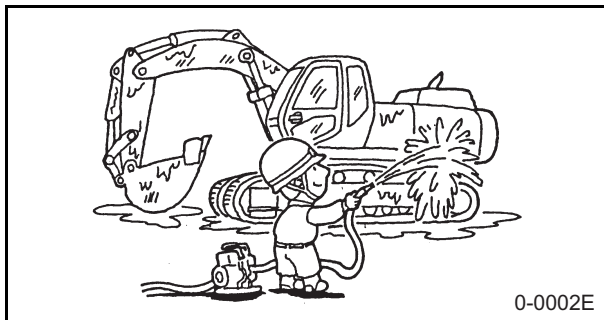

2. Performing Rust Prevention Operation.

⚠ CAUTION

Start the engine after you understand the operation methods.

- ① Set the engine at low~medium rpm and go through the warming up operation.
- ② Slowly operate each cylinder of the front attachment five strokes each.

3. If Storage Is To Be Continued
[Storage procedures for rust prevention.]

- ① Grease up each part of the attachment.

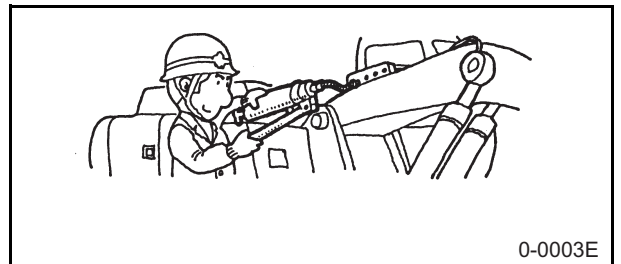

Storage for up to one month

- (1) Once a week operate each motion (attachment, swing, travel) with no load which performs rust prevention operation.
- ① Put the engine in low~medium rpm and perform the warming up operation.
- ② Slowly operate each cylinder of the front attachment five strokes each.

Storage for more than one month

- (1) Place each cylinder in the most retracted position and apply anti-rust oil to the exposed cylinder rod.

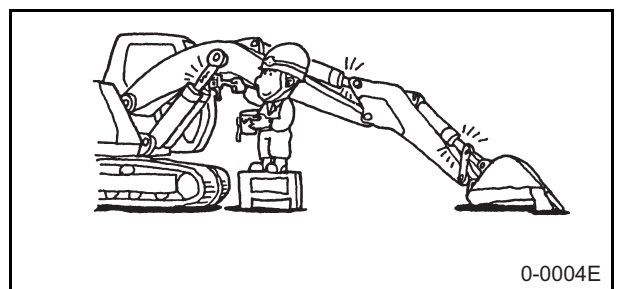

- (2) Perform rust-prevention operation once a month.
- ① Before performing the rust-prevention operation, remove the anti-rust oil (wipe off with kerosene, etc.).
- ② After finishing the rust prevention operation, fully retract each cylinder and apply anti-rust oil to the exposed cylinder rod.

For Safe Driving

SAFETY INSTRUCTIONS

Your safety and that of people around you depend on you. It is essential that you understand this manual for the correct operation, inspection, lubrication and maintenance of this machine.

Read this manual carefully and check that :

- You understand fully the symbols on the controls and the safety signs used in this manual and on the machine.
- You understand fully the speed, stability, braking and steering characteristics of the machine. If you are in any doubt, consult your CASE Dealer.

The safety messages in this manual concern situations which may arise during normal machine operation and servicing. These safety messages also indicate the different ways of coping with these situations. Other safety messages are used throughout the manual to indicate specific dangers.

Whatever type of work is being done (earthmoving, handling, drilling, etc.), the safety measures for private or public work-sites are those which conform to current regulations in the country concerned, or the type of operation concerned (mining, quarrying, tunnelling).

The safety instructions given in this manual are a summary of the basic rules to be respected at all times and do not exempt you from insurance requirements or from abiding by the highway code. Always keep this manual in the storage compartment "Pocket" provided for it. Make sure it is always complete and in good condition.

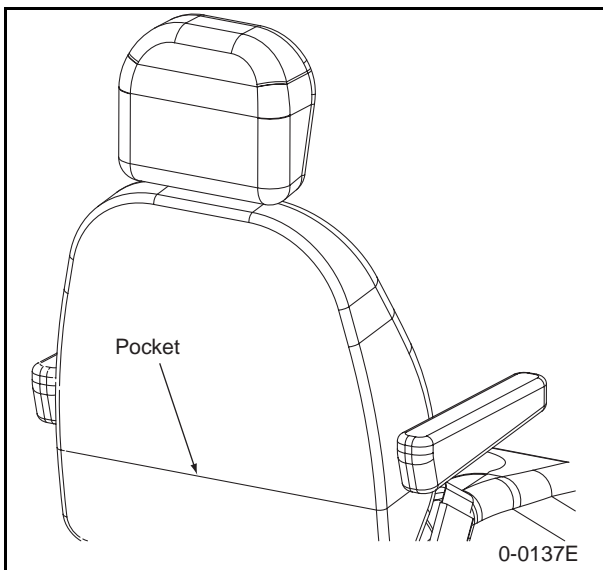

For Safe Driving

Warranty

In case faults occur to the machine, the warranty is valid within the range described in the warranty document.

Model and Serial number of manufacture

When ordering parts, obtaining information or assistance, always supply your CASE dealer with the type and serial number of your machine or accessories.

Write the following in the spaces below: The model number, serial number and year of manufacture of your machine, accessories and the serial number of the various hydraulic and mechanical components.

Machine

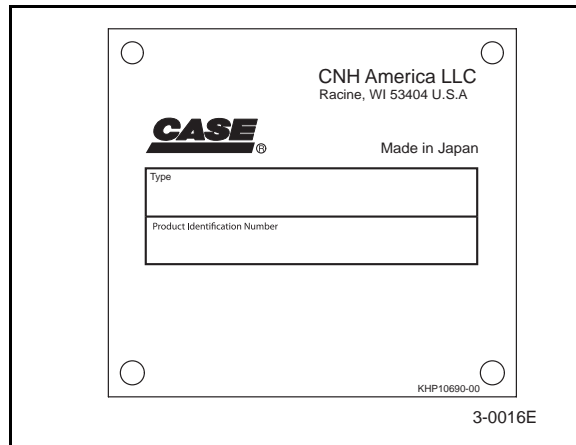
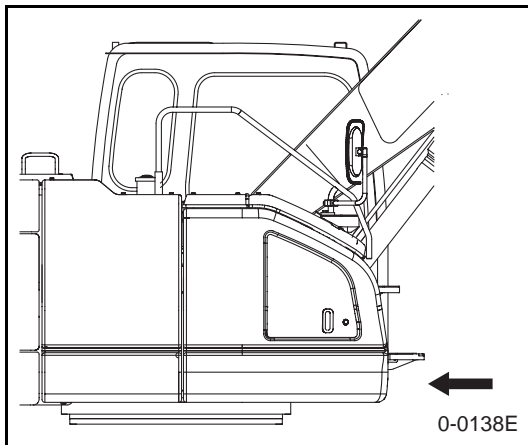

Excavator Identification _____

Model Number _____

Serial Number _____

Engine

Make and type _____

Serial number _____

Component serial numbers

Hydraulic pump _____

Swing reduction gear _____

Travel reduction gears _____

Travel control valve _____

Attachment control valve _____

Swing control valve _____

Table of Contents

To the Owner	0-1	Warm-up Operation.....	2-8
Safety Labels	0-2	Operations (Traveling).....	2-10
For Safe Driving	0-3	Operations (Swing).....	2-19
		Swing Operation.....	2-19
Safety Section	0-7	Operations (Attachment)	2-20
Precaution Identification Plates (DECALS)	0-8	Operations (Attachment)	2-20
Identification Plates inside the Cabin.....	0-8	Operations.....	2-21
Outside Identification Plate.....	0-13	Blade Operation	2-21
Precaution Identification Plates on Parts (Examples)	0-17	Characteristics of Hydraulic Excavator.....	2-21
		Cautions for operations	2-22
Prior to Operation.....	0-18	Cautions for Interference.....	2-22
Confirmation of Safety items	0-20	Operating Instructions (Cautions).....	2-24
During Operation.....	0-23	Operating Instructions (Procedures)	2-25
While Traveling	0-27	Bucket: Turning Over and Replacement	2-27
After Operating.....	0-28	Bucket: Turning Over and Replacement	2-27
While Transporting.....	0-29	On Completion of Daily Operations.....	2-29
Before Regular Inspection & Maintenance.....	0-30	On Completion of Daily Operations.....	2-29
Inspection and Maintenance	0-31	Operating in Cold Climates	2-31
		Operating under Extreme Conditions	2-32
Instruments and Controls	1-0	Transportation	2-33
Location of Components	1-1	Loading and Unloading	2-33
Overall View	1-1	Switch settings during loading and unloading	2-33
Operator's Cab	1-2	Transportation	2-33
Right Console.....	1-4	Storing	2-37
Right Console.....	1-4		
Monitor & Switch Panel.....	1-5	Inspections and Maintenance	3-0
Monitor & Switch Panel	1-5	General Cautions	3-1
Monitor Display	1-6	Periodic Maintenance Check List.....	3-2
Switch Panel	1-7	Daily Inspections (Prior to Operation)	3-2
Left Console	1-9	Periodic Maintenance Check List	3-3
Left Console	1-9	Fuel / Lubricants for Different Ambient Temperature	
Switch.....	1-10	Settings	3-4
Air Conditioner	1-11	Genuine CASE Company LLC Parts and Elements.....	3-5
Air Conditioner (If equipped).....	1-11	Disposable Items.....	3-6
Explanation of device	1-13	Grease / Oil and Elements	3-7
Radio	1-13	Inspection Prior to Operation.....	3-9
Operation Levers.....	1-15	Inspections Prior to Operation.....	3-9
Operation Levers.....	1-15	Greasing Attachments.....	3-13
Operator's Seat.....	1-18	Greasing Front Attachment Pins	3-13
Operator's Seat	1-18	Fuel System	3-15
Operator's Cab.....	1-20	Fuel	3-15
Fuses	1-22	Fuel Refilling and Fuel Level Checking	3-18
Fuses.....	1-22	Drainage of Water and Sediments in the Fuel Tank	
Explanation of device	1-23	3-18
Battery	1-23	Draining Water from the Pre Fuel Filter.....	3-19
Starting the Engine by Using Booster Cables	1-24	Pre Fuel Filter Replacement.....	3-20
		Draining Water from the Fuel Filter (Main)	3-21
		Fuel Filter (Main) Replacement.....	3-21
Operating Instructions	2-0	Engine	3-23
Operation of New Machine.....	2-1	Engine Oil Replacement.....	3-23
Using a New Machine.....	2-1	Engine Oil Filter Replacement.....	3-23
Daily Inspections	2-2	Cooling System	3-25
Daily Inspections	2-2	Inspecting and Refilling Coolant.....	3-25
Starting and Stopping the Engine	2-4	Replacing the Coolant	3-26
Inspections before Starting the Engine.....	2-4	Cleaning and Inspecting the Radiator Net and Fin	
Starting the Engine	2-5	3-27
Inspections after Starting the Engine.....	2-6	Cleaning and Replacing the Air Cleaner (double ele-	
Stopping the Engine (Normal Operation)	2-7	ments)	3-28
Warm-up Operation.....	2-8	Inspection and Adjustment of Fan Belt.....	3-30



Table of Contents

Bolt Torque	3-31	Specifications	4-2
Bolt and Nut Torque	3-31	CX225SR	4-2
Hydraulic Oil.....	3-34	CX225SR (with BLADE)	4-13
Hydraulic Oil Level Inspection.....	3-34	Optional Components	5-0
Refilling Hydraulic Oil.....	3-34	Breakers.....	5-1
Draining Water and Sediment from the Hydraulic Oil		Handling the Breaker (Attachment).....	5-1
Tank	3-35	When Using a Hydraulic Breaker.....	5-2
Hydraulic Oil Management.....	3-36	Operating the breaker	5-4
Hydraulic Oil Replacement.....	3-36	Importance of Hydraulic oil Control.....	5-5
Bleeding Air from the Hydraulic Components	3-37	Crusher	5-7
Air Bleeding Procedures	3-37	Using the Crusher (Attachment)	5-7
Air Bleeding from Hydraulic Pump	3-37	Load Lifting Operation.....	5-10
Air Bleeding from Cylinder	3-38		
Air Bleeding from Swing Motor.....	3-38		
Cleaning and Replacing Suction Filter	3-39		
Replacing Return Filter	3-39		
Replacing Air Breather Element.....	3-40		
Replacing Pilot Oil Filter Element.....	3-40		
Replacement Intervals for Hydraulic Oil and Filters when			
Using Breaker.....	3-41		
Checking Hoses and Lines	3-41		
Battery.....	3-42		
Battery Inspection and Charge.....	3-42		
Upper Frame.....	3-44		
Turntable Bearing Greasing	3-44		
Greasing Swing Ring Gear	3-44		
Swing Unit.....	3-45		
Oil Level Inspection and Refilling of Swing Reduction			
Gear	3-45		
Oil Replacement for Swing Reduction Gear	3-45		
Greasing Swing Reduction Gear.....	3-46		
Travel Unit.....	3-47		
Travel Reduction Gear	3-47		
Oil Level Inspection and Refilling of Travel Reduction			
Gear	3-47		
Oil Replacement for Travel Reduction Gear	3-47		
Inspecting Upper/Lower Take-up Roller (Idler Wheel)			
.....	3-48		
Inspection and Tightening of Shoe Plate	3-48		
Cleaning Crawler.....	3-48		
Inspection and Adjustment of Track Shoe Tension			
.....	3-49		
Bucket.....	3-50		
Replacing Bucket Teeth: Standard type (Length Pin			
Type)	3-50		
Replacing Bucket Tooth: Standard type (Side pin type)			
.....	3-52		
Replacing Bucket Teeth: Heavy Digging Type.....	3-53		
Adjustment of Bucket Backlash.....	3-54		
Air Conditioner	3-55		
Inspection and Care of Air Conditioner (If Equipped)			
.....	3-55		
Routine Replacement Safety Parts.....	3-59		
Troubleshooting	3-60		
Contacting Us	3-65		
Specifications	4-0		
Conversion Factors.....	4-1		
CONVERSION FACTORS.....	4-1		

Safety Section

WARNING

**You must read this safety section carefully.
This section contains important safety information.**

The  symbols on precaution film labels are attached to machines in order to prevent personal injury. Before starting operations, read carefully the indications on film labels with  symbols.

It is a very difficult task to cover and handle all possible dangers in this manual. For this reason, the descriptions on precaution film labels do not always cover everything. Try to understand fully this manual and drive and operate properly, paying special attention to prevent damage to the machine or personal injury.

Contents of the manual

- Precaution Identification Plates (DECALS)
- Prior to Operation
- Confirmation of Safety items
- During Operation
- While Traveling
- After Operating
- While Transporting
- Before Regular Inspection & Maintenance
- Inspection and Maintenance

Safety

Precaution Identification Plates (DECALS)

Always keep the precaution ID label clear and readable.

When the plate gets dirty:

Clean the plate with water or washing agent. Don't use any gasoline or organic solvent.

If a precaution identification plate is extremely dirty and the dirt is difficult to remove, replace it with a new one.

Before changing it, make sure it is the same type.

In case Precaution Identification Plates are lost or damaged:



Ask for a new precaution identification plate at the nearest approved sales shop.

Before changing it, make sure it is the same type.

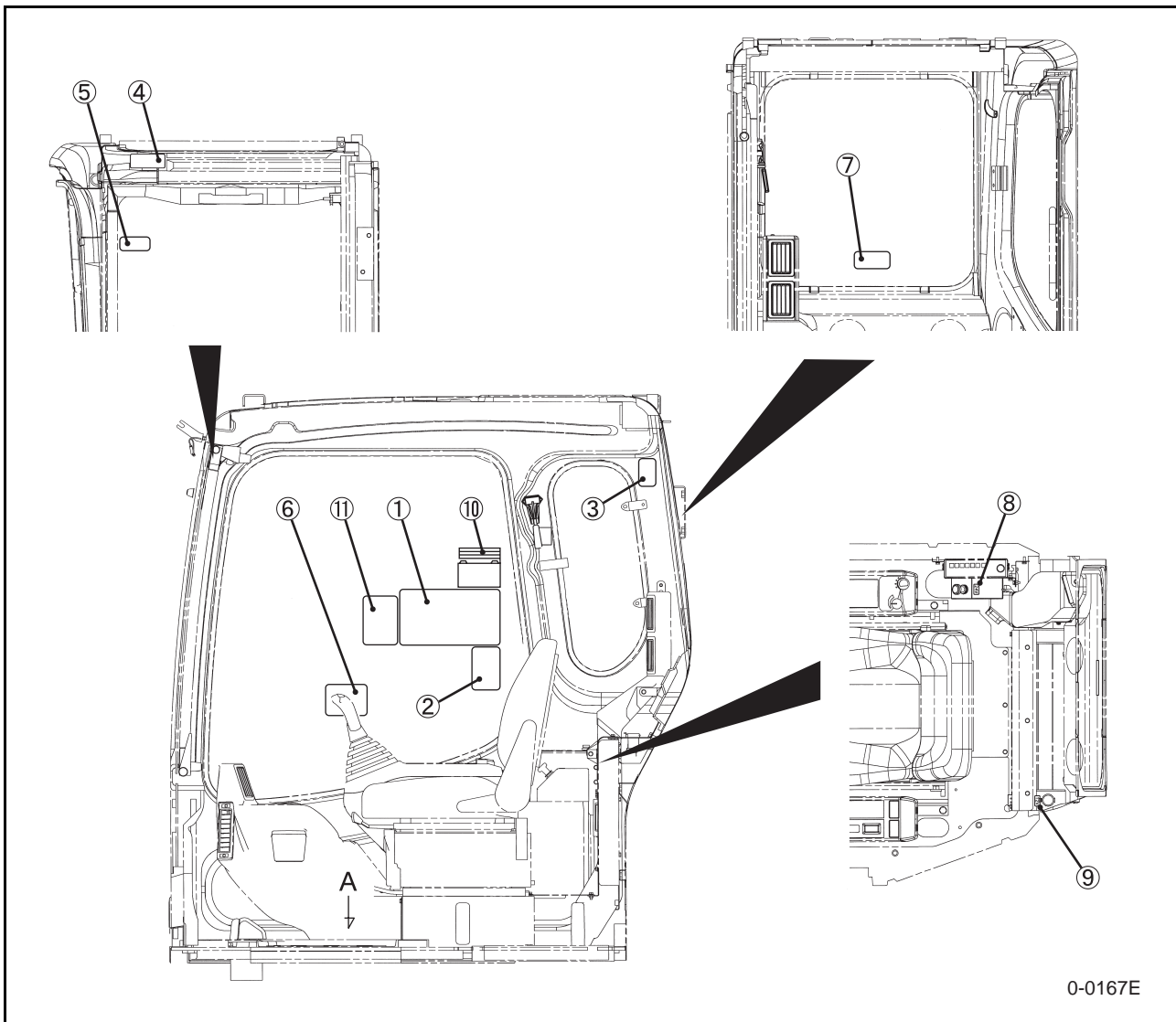
Identification Plates inside the Cabin

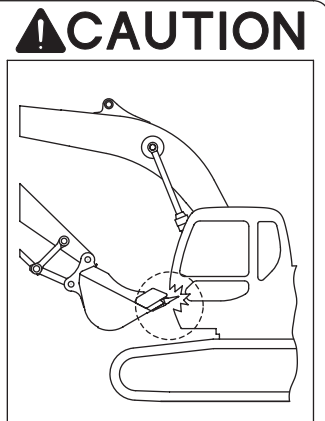

① WARNING Label KHP1537

A ↓	B ↓	C ↓
 <p>⚠ DANGER</p> <p>ELECTROCUTION HAZARD. CONTACT WITH EXCAVATOR OR GROUND MAY CAUSE DEATH OR BODILY INJURY. KEEP ALL PARTS OF MACHINE AND LOAD AT LEAST 15 FEET (4.57M) AWAY FROM ALL ELECTRICAL POWER LINES OR SUCH DISTANCE AS SPECIFIED BY LOCAL SAFETY CODES.</p>	 <p>⚠</p> <p>IMPROPER EXCAVATOR OPERATION AND MAINTENANCE CAN CAUSE INJURY OR DEATH. READ AND STUDY THE OPERATOR'S MANUAL AND ALL SAFETY MESSAGES. LEARN AND PRACTICE SAFE USE OF CONTROLS. ALWAYS OPERATE PROPERLY. INSPECT AND MAINTAIN EXCAVATOR DAILY.</p>	 <p>⚠ CAUTION</p> <p>Attachment interference. Machine damage may result. Do not allow the attachment, load or other devices to contact the cab or machine.</p>
<small>KHP1537-00</small>		0-0150E

Ⓐ Electric shocks

If you let the machine go too close to electric wires, you could get an electric shock.

Keep a safe distance and away from electric wires.

Guidelines for Safe Distances.

Voltage	Safe Distance
6,600 V or less	6.6 ft (2 m) or more
22,000 V or less	9.8 ft (3 m) or more
66,000 V or less	13.1 ft (4 m) or more
154,000 V or less	16.4 ft (5 m) or more
187,000 V or less	19.7 ft (6 m) or more
275,000 V or less	23.0 ft (7 m) or more
500,000 V or less	36.1 ft (11 m) or more



DANGER



ELECTROCUTION HAZARD.
CONTACT WITH EXCAVATOR OR GROUND MAY CAUSE DEATH OR BODILY INJURY.
KEEP ALL PARTS OF MACHINE AND LOAD AT LEAST 15 FEET (4.57M) AWAY FROM ALL ELECTRICAL POWER LINES OR SUCH DISTANCE AS SPECIFIED BY LOCAL SAFETY CODES.

0-0151E

Safety

Precaution Identification Plates (DECALS)

Ⓑ Read manual before driving and maintenance

This is very important. You must read this carefully. You must read the manual before driving, maintaining, disassembling/assembling or transporting your machine.

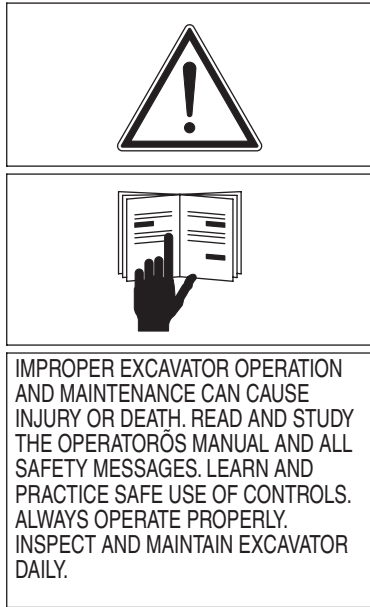

0-0152E

Ⓒ Raise gatelock lever KHP1782

Raise lever completely to shut off controls before leaving the cab to avoid accidental control engagement and possible injury.

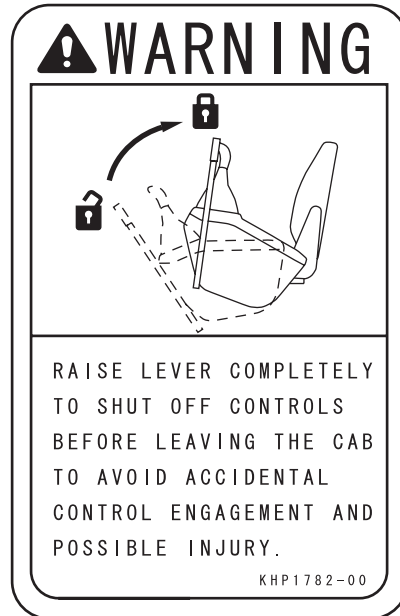

0-0153E

Ⓓ Attachment interference with cab

The bucket teeth may hit the cab, depending on the type of attachment. Exercise care when operating a bucket near the cab.

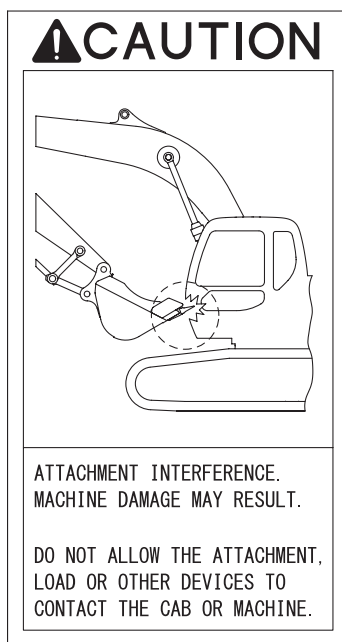

0-0014E

Ⓔ Caution against the fall of front window KHP1822

There is a danger of an injury due to possible sliding fall of the stored front window.

Be sure to lock the front window securely at the position to be stored.

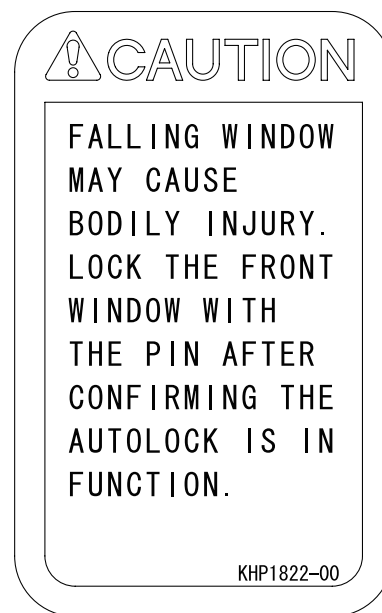

0-0154E

④ Lock pin KHP1802

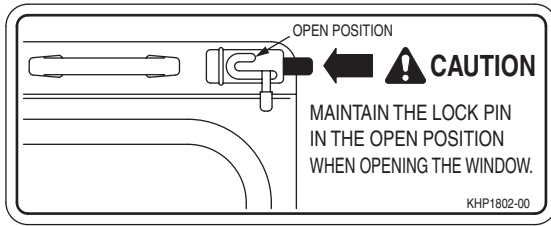

0-0155E

⑤ Cleaning the cab window KHP1540

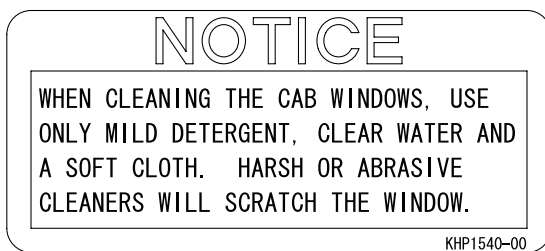

0-0156E

⑥ Exchange of control function KHP1050

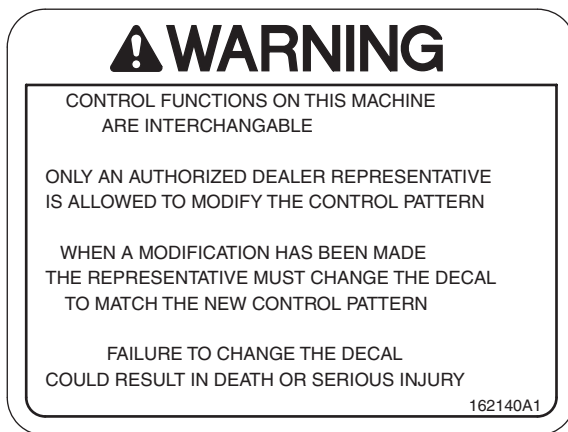

0-0157E

⑦ Emergency exit KHP1247

If the door or window cannot be opened and you must get outside in an emergency, use the hammer installed to brake the rear window and escape through it.



0-0144E

⑧ For use of cigarette lighter socket KHP1804

The cigarette lighter located in the right back of the operator's seat is of DC24V rating.

It is strictly prohibited to connect any of the equipment of 12V rating as this causes it to be damaged.



0-0145E

⑨ 12V Power socket KHP1803

A 12V power socket is supply power to electric equipment and accessories for automobile use.



1-0033

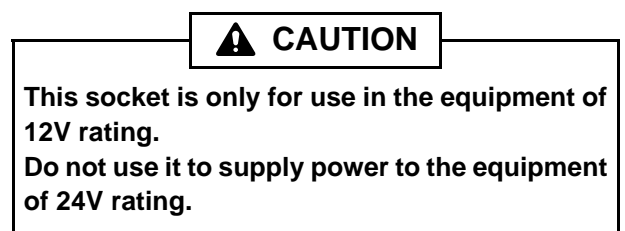

⑩ Control pattern selector KHP1587

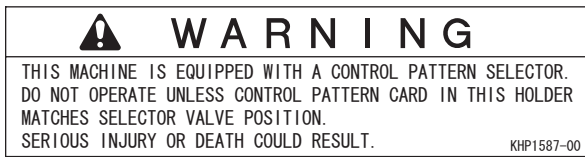

0-0017E

⑪ Blade (Blade spec.) KHP1316

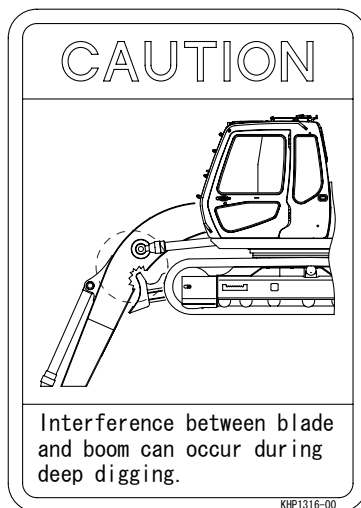

0-0133E

Outside Identification Plate

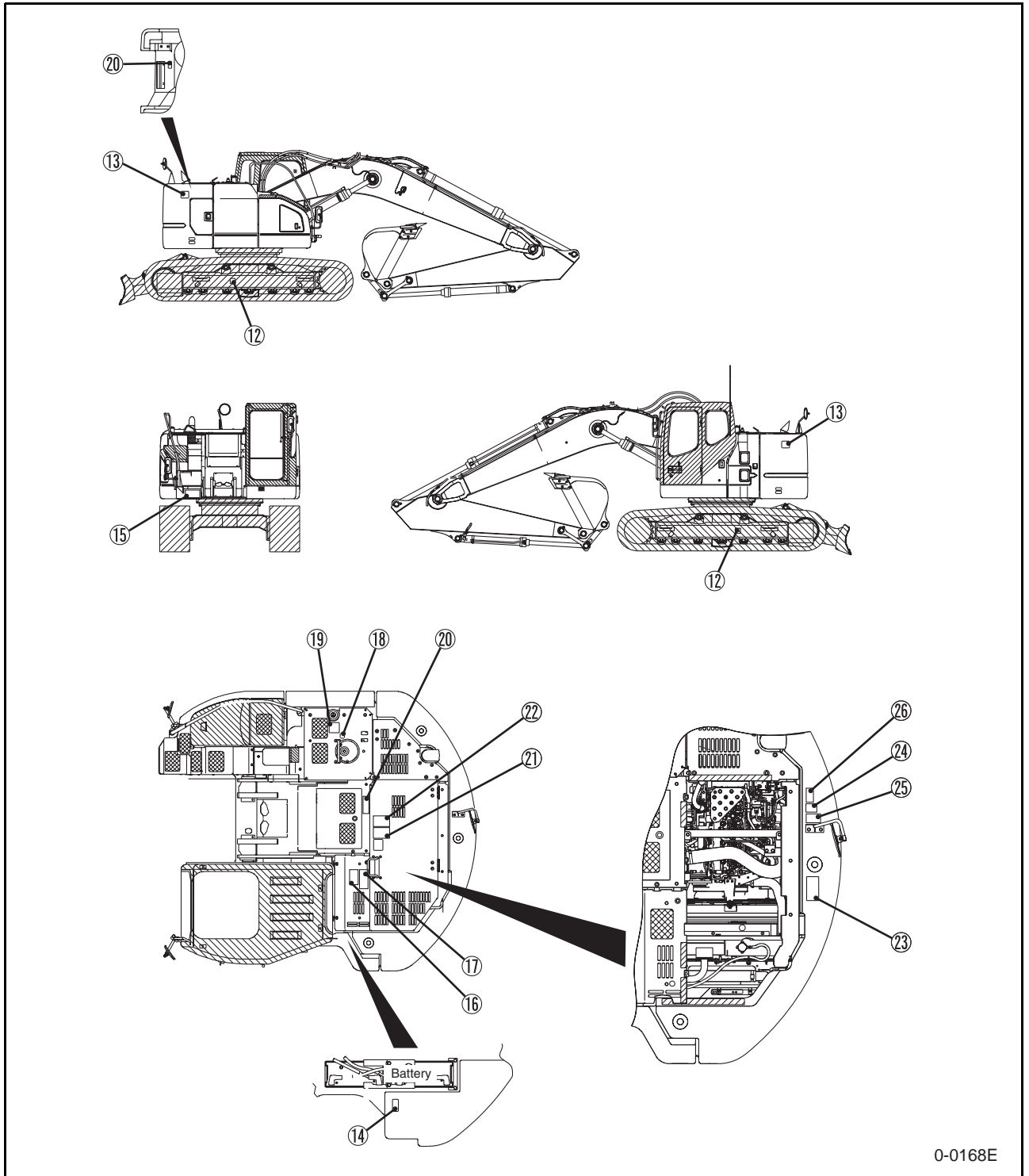

Safety

Precaution Identification Plates (DECALS)

⑫ Shoe (crawler belt) tension KHP1014

Plug could pop out from the shoe (crawler belt) tension adjustment device.
When releasing the shoe, read the manual and handle shoes properly.



0-0019E

⑬ Keep out of the range of turns KHP1532

When the machine makes a turn, you may be caught in the upper part of the turning body.
Do not attempt to enter within the range of the turns.

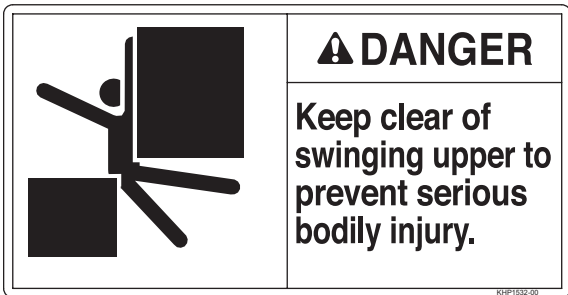

0-0086E

⑭ Battery explosion KHP1536

The wrong handling of battery causes explosion itself.
You must read the manual before maintaining battery.

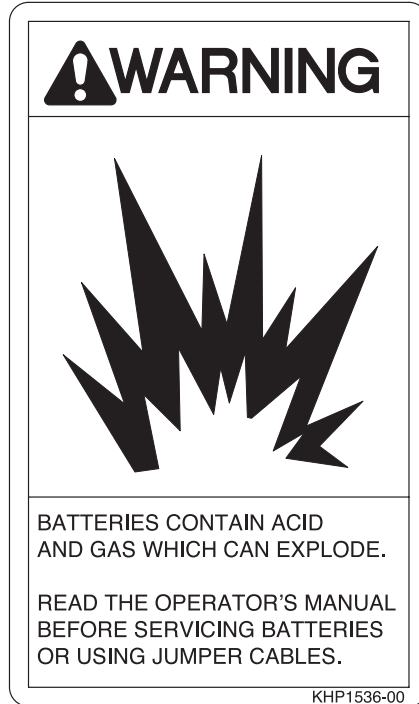

0-0032E

⑮ Electric shocks KHP0210

If you let the machine go too close to electric wires, you could get an electric shock.
Keep a safe distance and away from electric wires.
Guidelines for Safe Distances.

Voltage	Safe Distance
6,600 V or less	6.6 ft (2 m) or more
22,000 V or less	9.8 ft (3 m) or more
66,000 V or less	13.1 ft (4 m) or more
154,000 V or less	16.4 ft (5 m) or more
187,000 V or less	19.7 ft (6 m) or more
275,000 V or less	23.0 ft (7 m) or more
500,000 V or less	36.1 ft (11 m) or more

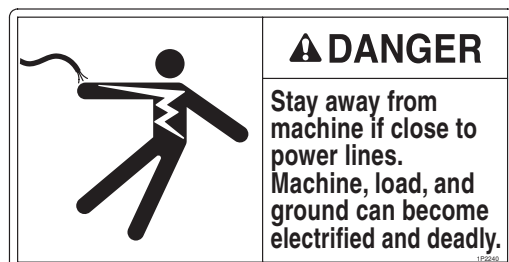

0-0020E

⑩ Entanglement KHP1533

Entanglement in rotating parts of the fun could cause injury.

Always stop the rotating engine when conducting inspection and maintenance.

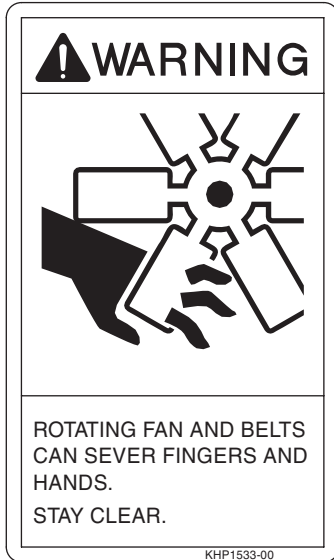

0-0021E

⑪ Relieving pressure KHP1534

You can relieving the pressure from the reservoir by removing cap.



0-0022E

⑫ Relieving pressure KHP1542

You can relieving the pressure from the reservoir before removing tank cap.

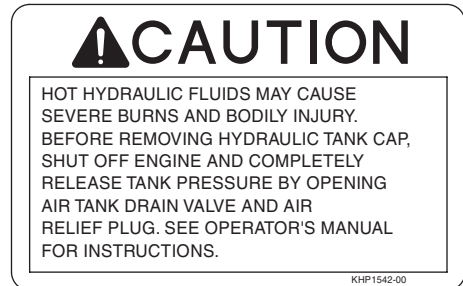

0-0023E

⑬ Diesel Fuel KHP11681

The location of the fuel tank.

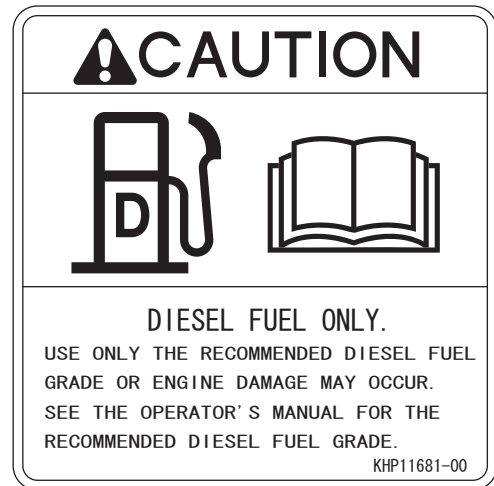

0-0024E

⑭ Hot surfaces KHP1535

The exhaust system must never be touched while the engine is running or immediately after the engine has stopped.

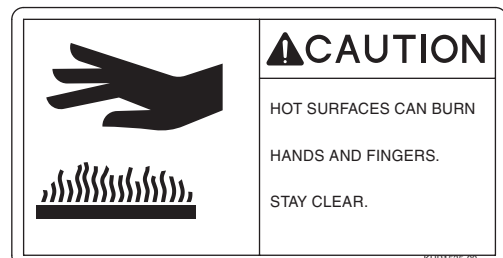

0-0025E

Safety

Precaution Identification Plates (DECALS)

⑳ Do not walk on Engine cover
KHP1011



0-0026E

㉑ Start Engine from Operator Seat
KHP0713



0-0075E

㉒ Engine Hood handling KHP1010



0-0027E

㉓ Jumper Cable Connection
KHP0700

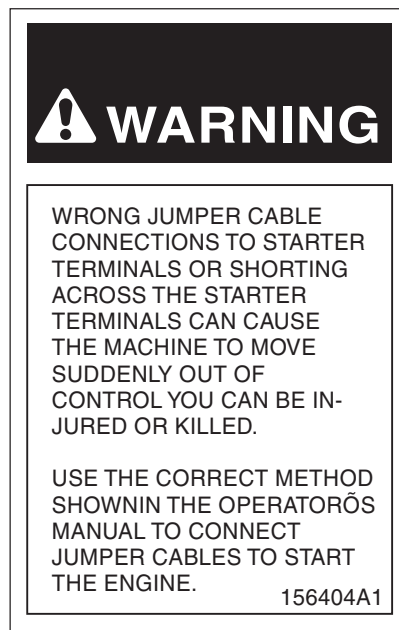

0-0076E

㉔ Fall attention KHP12210



0-0028E

㉕ Do not open high pressure fuel system KHP13150

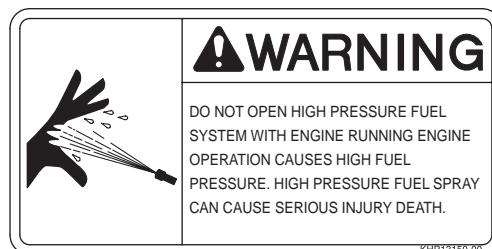

0-0114E