

**CX17B
Tier 4
Hydraulic Excavator**

Operator's Manual

Print No. S2PU00014ZE01

1st edition

English 03/10

From serial no. NATN16300



CX17B TIER 4 HYDRAULIC EXCAVATOR

OPERATOR'S MANUAL

Part Number: S2PU00014ZE01

Applicable Pin Number: NATN16300 and higher

CASE CONSTRUCTION TECHNICAL MANUALS

Manuals are available from your Dealer for the operation, service, and repair of your machine. For prompt convenient service, contact your Dealer for assistance in obtaining the manuals for your machine.

Your Dealer can expedite your order for Operator's Manuals, Parts Catalogs, Service Manuals, and Maintenance records.

Always give the Machine Name, Model, and P.I.N. (Product Identification Number) or S.N. (Serial Number) of your machine so your Dealer can provide the correct manuals for your machine.

NOTE: *CNH America LLC reserves the right to make improvements in design or changes in specifications at any time without incurring any obligation to install them on units previously sold.*



THIS SAFETY ALERT SYMBOL INDICATES IMPORTANT SAFETY MESSAGES IN THIS MANUAL. WHEN YOU SEE THIS SYMBOL, CAREFULLY READ THE MESSAGE THAT FOLLOWS AND BE ALERT TO THE POSSIBILITY OF DEATH OR SERIOUS INJURY

M171D

Safety Decals on this machine use the words **Danger, Warning, or Caution,**

- **DANGER:** Indicates an immediate hazardous situation that, if not avoided, will result in death or serious injury. The color associated with Danger is RED.

Indicates a potentially hazardous situation that, if not avoided, could result in death or serious injury. The color associated with Warning is ORANGE.

Indicates a potentially hazardous situation which, if not avoided, may result in minor or moderate injury. It may also be used to alert against unsafe practices. The color associated with Caution is YELLOW.

If Safety Decals on this machine are ISO two panel Pictorial, decals are defined as follows:

The first panel indicates the nature of the hazard.

The second panel indicates the appropriate avoidance of the hazard.

Background color is YELLOW

Prohibition symbols such as   and  if used, are RED.



WARNING

IMPROPER OPERATION OF THIS MACHINE CAN CAUSE DEATH OR SERIOUS INJURY. BEFORE USING THIS MACHINE, MAKE CERTAIN THAT EVERY OPERATOR:

Is instructed in safe and proper use of the machine.

Reads and understands the Manual(s) pertaining to the machine.

Reads and understands ALL Safety Decals on the machine.

Clears the area of other persons.

Learns and practices safe use of machine controls in a safe, clear area before operating this machine on a job site.

It is your responsibility to observe pertinent laws and regulations and follow CNH America, LLC instructions on machine operation and maintenance.

WARNING_01_NA

CALIFORNIA

PROPOSITION 65 WARNING

Diesel engine exhaust and some of its constituents are known to the State of California to cause cancer, birth defects, and other reproductive harm.

Battery post, terminals and related accessories contain lead and lead compounds.
Wash hands after handling.

TABLE OF CONTENTS

CHAPTER 1

GENERAL INFORMATION

To the Owner	1-1
Right, Left, Front, and Rear of the Machine	1-2
Machine Components	1-3
Identification Numbers	1-4

CHAPTER 2

SAFETY, DECALS, AND HAND SIGNALS

Table of Contents	2-1
Safety Rules	2-3
Operator Precautions	2-5
Decals	2-10
Hand Signals	2-25

CHAPTER 3

INSTRUMENTS AND CONTROLS

Table of Contents	3-1
Operator Cab and Operator Seat	3-3
Machine Access Compartments and Doors	3-7
Operator's Compartment Controls and Accessories	3-8

CHAPTER 4

OPERATING INSTRUCTIONS

Table of Contents	4-1
Before Operating the Machine	4-3
Operating the Machine	4-3
Starting and Stopping Machine Engine	4-4
Starting and Stopping Machine Engine in Cold Climates	4-5
Control Decal	4-8
Basic Operation of Hydraulic Controls	4-10
Practices to Improve Efficiency	4-20
Transportation	4-27
Machine Storage	4-32
Optional Equipment	4-33
Hydraulic Breaker	4-33

CHAPTER 5

LUBRICATION, FILTERS, AND FLUIDS

Table of Contents	5-1
Fluids and Filters	5-3
Lubricant Specifications	5-5

CHAPTER 6

MAINTENANCE AND ADJUSTMENTS

Table of Contents	6-1
General Information	6-3
General Safety	6-3
Releasing Pressure in the Hydraulic System	6-6
Lubrication and Maintenance Quick Reference Chart	6-8
Daily Inspection and Maintenance	6-10
50 hour maintenance:	6-16
250 Hour Maintenance	6-25
500 Hour Maintenance	6-31
1000 Hour Maintenance	6-35

1500 Hour Maintenance	6-38
2000 Hour Maintenance	6-39
5000 Hour Maintenance	6-48
Special Procedures	6-49

CHAPTER 7

ELECTRICAL

Table of Contents	7-1
-------------------------	-----

CHAPTER 8

SPECIFICATIONS

Table of Contents	8-1
General Specifications	8-3
Lifting Capacities	8-9
Torque Specifications	8-10

CHAPTER 9

INDEX

GENERAL INFORMATION

TO THE OWNER

CX17B HYDRAULIC EXCAVATOR

Your machine has been designed and built to the highest standards of quality. It conforms to all current safety regulations. The risk of accidents can never be completely excluded. That is why it is essential to observe elementary safety rules and precautions.

Read this manual carefully, paying particular attention to the instructions concerning safety, operation and maintenance to avoid the risk of injury while operating or servicing the machine.

The standard attachments and tools of this machine are designed to carry out all kinds of earth moving and rehandling operations. If you want to use this machine to handle a load (pipes, culverts, formwork, etc.), make sure that it is equipped for this type of work. For these applications, the machine must be equipped with safety valves, a load handling chart corresponding to the type of machine and its attachment, and a load fixing point. All legal requirements must also be strictly observed.

Do not use this machine for any application or purpose other than those described in this manual. If the machine is to be used for work involving the use of special attachments, accessories or equipment, consult your Case dealer in order to make sure that any adaptations or modifications made are in keeping with the machine's technical specifications and with prevailing safety requirements.

Any modification or adaptation which is not approved by the manufacturer may invalidate the machine's initial conformity with safety requirements.

The machine must undergo regular inspections, the frequency of which varies according to the type of use. Consult your Case dealer.

Before permitting a new operator on this machine, make certain:

That the operator has received the necessary training on how to operate the machine correctly and safely.

That the operator has read and understood the instructions given in this manual.

Contact your dealer for operator manuals translated into Spanish or French Canadian.

Always keep this manual in the operator's compartment in its designated storage space. Make sure it is complete and in good condition. If you wish to obtain extra copies, or copies in languages other than that of the country of use, consult your Case dealer.

Your Case dealer is available for any further information. They will also provide any after-sales service you may need, and genuine Case spare parts, your guarantee of quality and match.

RIGHT, LEFT, FRONT, AND REAR OF THE MACHINE

The terms **Right-hand**, **Left-hand**, **Front**, and **Rear** are used in this manual to indicate the sides as they are seen from the operator's seat when the cab is over the idler wheels.

The following illustration shows the machine in normal **TRAVEL** position. In normal **TRAVEL** position, the cab is over the idler wheels. The travel reduction gears are at the rear of the upper structure.

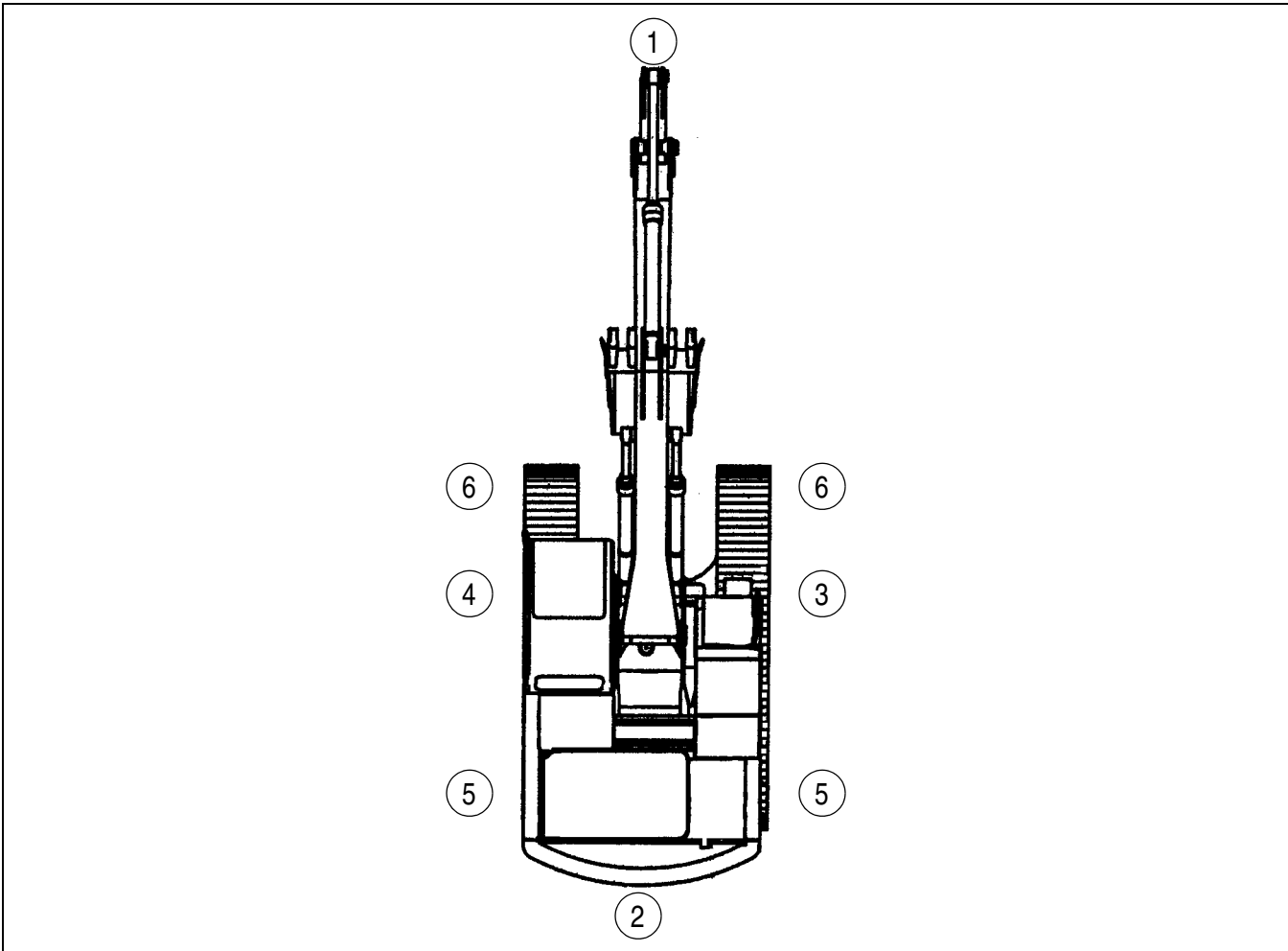

DC03H142

Figure 1

1. FRONT
2. REAR

3. RIGHT HAND SIDE
4. LEFT HAND SIDE

5. TRAVEL REDUCTION GEARS (TRAVEL MOTORS)
6. IDLER WHEELS

MACHINE COMPONENTS

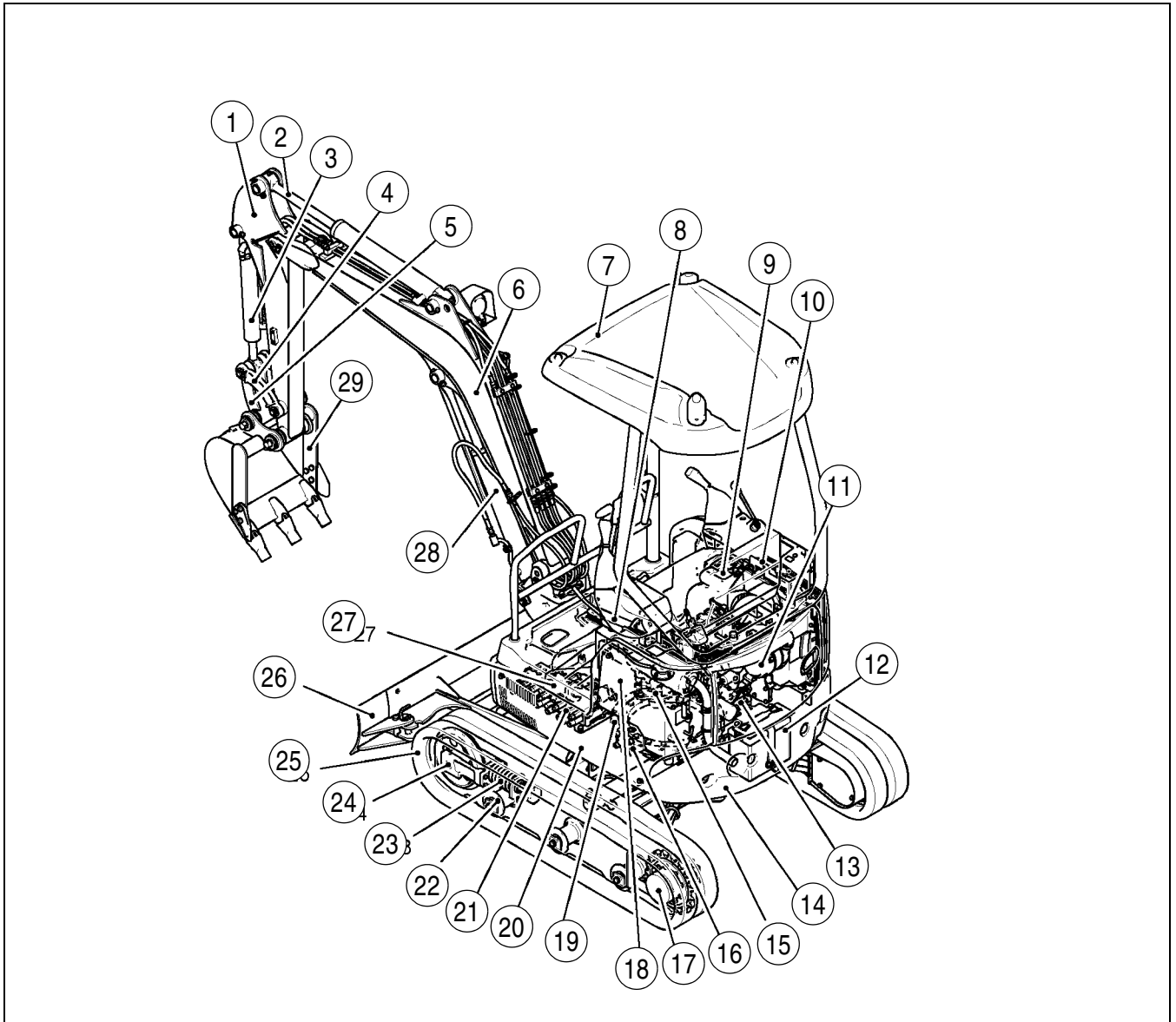

RH09H184

Figure 2

MACHINE COMPONENTS

- | | | |
|--------------------------|---------------------|--------------------|
| 1. ARM | 11. AIR CLEANER | 21. CONTROL VALVE |
| 2. ARM CYLINDER | 12. BATTERY | 22. LOWET ROLLER |
| 3. BUCKET CYLINDER | 13. ENGINE | 23. IDLER ADJUST |
| 4. IDLER LINK | 14. COUNTER WEIGHT | 24. FRONT IDLER |
| 5. BUCKET LINK | 15. SLEWING MOTOR | 25. SHOE |
| 6. BOOM | 16. HYDRAULIC PUMP | 26. DOZER |
| 7. CANOPY | 17. TRAVEL MOTOR | 27. DOZER CYLINDER |
| 8. SWING CYLINDER | 18. HYDRAULIC TANK | 28. BOOM CYLINDER |
| 9. FUEL TANK | 19. SLEWING BEARING | 29. BUCKET |
| 10. RADIATOR, OIL COOLER | 20. GUARD | |

IDENTIFICATION NUMBERS

MODEL, SERIAL NUMBER, AND YEAR OF MANUFACTURE

When ordering parts, obtaining information or assistance, always supply your Case Construction, LLC Dealer with the type and serial number of your machine or accessories.

Write the following in the spaces below: The type, serial number and year of manufacture of your machine, accessories and the serial numbers of the various hydraulic and mechanical components.

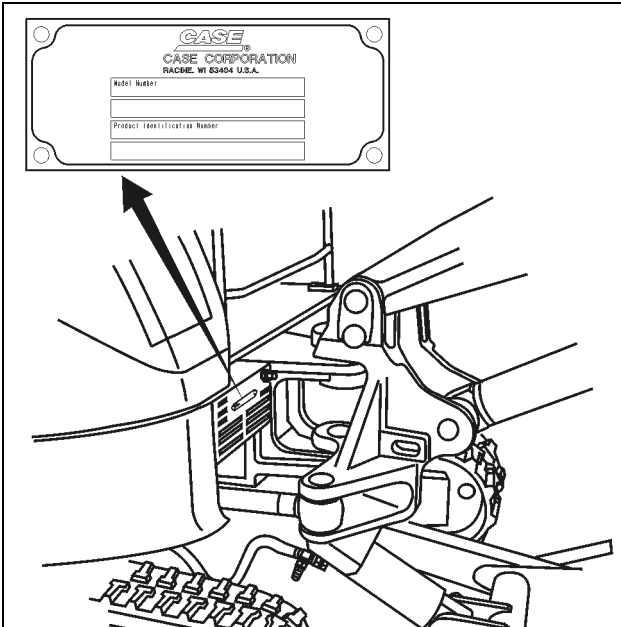

BS07N400

Figure 3

PRODUCT IDENTIFICATION PLATE	
➤ _____	Model
➤ _____	Serial Number
➤ _____	Manufacturing Year

ENGINE

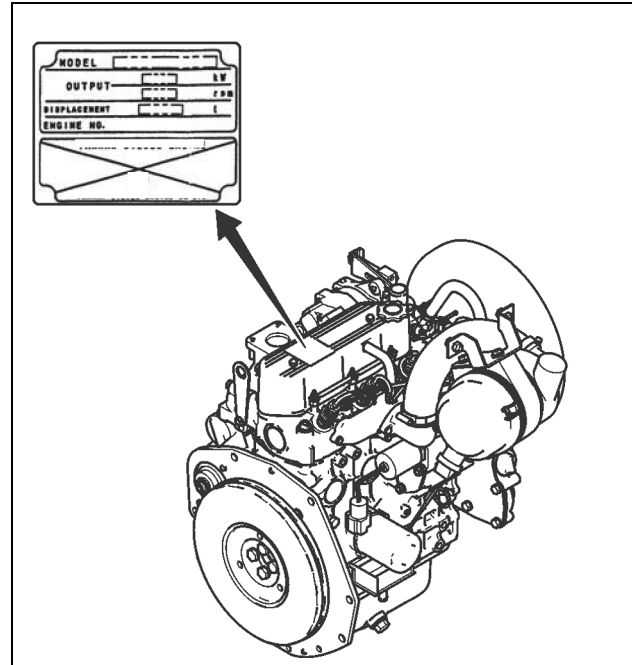

BS10B052

Figure 4

ENGINE	
➤ _____	Make and Model
➤ _____	Serial Number

FOPS ROPS CERTIFICATION

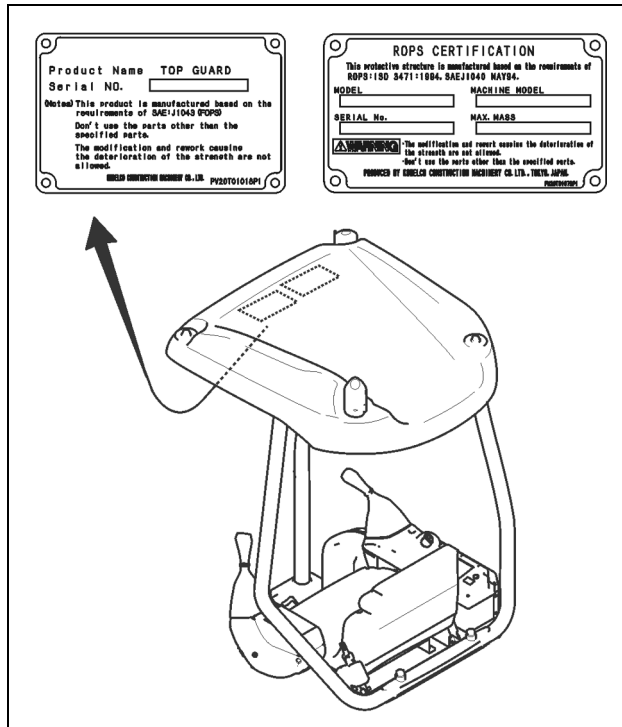

RH10B051

Figure 5

COMPONENT SERIAL NUMBERS

COMPONENT SERIAL NUMBERS	
➤ _____	Hydraulic Pump
➤ _____	Swing Reduction Gear
➤ _____	Travel Reduction Gears
➤ _____	Travel Control Valve
➤ _____	Attachment Control Valve
➤ _____	Swing Control Valve

ROPS/FOPS SERIAL NUMBERS

PRODUCT IDENTIFICATION PLATE	
➤ _____	FOPS Serial Number
➤ _____	ROPS Certification