

**9050B Excavator**

**9050B**

**9050B Excavator**  
**Operators Manual**

**Bur 9-25850**

FRONT COVER



***This symbol means ATTENTION! BECOME ALERT! YOUR SAFETY IS INVOLVED. The message that follows the symbol contains important information about safety. Carefully read the message. Make sure you fully understand the causes of possible injury or death.***

SB001

IF THIS MACHINE IS USED BY AN EMPLOYEE, IS LOANED, OR IS RENTED, MAKE SURE THAT THE OPERATOR UNDERSTANDS THE TWO INSTRUCTIONS BELOW.

BEFORE THE OPERATOR STARTS THE ENGINE:

1. GIVE INSTRUCTIONS TO THE OPERATOR ON SAFE AND CORRECT USE OF THE MACHINE.
2. MAKE SURE THE OPERATOR READS AND UNDERSTANDS THE OPERATOR'S MANUAL FOR THIS MACHINE.



# WARNING

**IMPROPER OPERATION OF THIS MACHINE CAN CAUSE INJURY OR DEATH.**

**BEFORE STARTING THE ENGINE, DO THE FOLLOWING:**

1. READ THE OPERATOR'S MANUAL.
2. READ ALL THE SAFETY DECALS ON THE MACHINE.
3. CLEAR THE AREA OF OTHER PERSONS.

**LEARN AND PRACTICE SAFE USE OF MACHINE CONTROLS IN A SAFE, CLEAR AREA BEFORE YOU OPERATE THIS MACHINE ON A JOB SITE.**

It is your responsibility to observe pertinent laws and regulations and to follow manufacturer's instructions on machine operation and maintenance.

See your Authorized Case dealer for additional operator's manuals, parts catalogs, and service manuals.

**NOTE:** The Case Corporation reserves the right to make improvements in design or changes in specifications at any time without incurring any obligation for installation on units previously sold.

CASE and CASE IH are registered trademarks of Case Corporation.

Copyright © 1995 Case Corporation

Bur 9-25850  
Issued April, 1995

# GENERAL TABLE OF CONTENTS

To the Owner of a Case Machine .....	2
Identification Numbers/Machine Components .....	4, 5 and 6
Safety/Decals/Hand Signals .....	7
Instruments and Controls .....	27
Operating Instructions .....	53
Tracks .....	81
Lubrication/Maintenance Charts .....	85
Lubrication/Filters/Fluids .....	93
Maintenance and Adjustments .....	123
Electrical System .....	129
Machine Storage .....	133
Specifications .....	135
After Delivery Check .....	153
Alphabetical Index .....	157



TRIM THIS EDGE

TRIM THIS EDGE

RIGHT PAGE

## TO THE OWNER

This manual contains important information about the safe operation, adjustment, service and maintenance of your Case Excavator. Do not operate or permit anyone else to operate or service this machine until you or the other persons have read this manual. Use only trained operators who have demonstrated the ability to operate and service this machine correctly and safely.



A27414

This excavator, with standard attachments and equipment, is intended to be used for below ground level digging and general earthmoving purposes, such as trenching, truck loading, material rehandling, and ditch cleaning.

If this excavator is to be used to lift loads, for safety purposes it is recommended that the machine is properly equipped. Contact your Case dealer and install a "Load Holding Control Device" on your machine's boom cylinders. This system prevents the sudden lowering of the load in the event of a failure of a hydraulic hose, line, or fitting in the boom hydraulic system. Such a failure can cause personal injury or death. Read "Lifting Loads with the Machine" in this manual and follow the instructions and safety precautions. See page 75.

Do not use this machine for any application or purpose other than those described in this manual. If the machine is to be used in an application that involves special attachments or equipment, such as forestry, demolition, etc., consult an authorized Case dealer or the Case Corporation. Changes, additions, or modifications can be required for the machine to comply with safety requirements. Unauthorized modifications can cause serious injury or death. Anyone making such unauthorized modifications is responsible for the consequences.

TO THE OWNER \_\_\_\_\_

Two copies of the After Delivery Check are in the back of this manual. One copy is for you and one copy is for the dealer. Make sure that your dealer does the After Delivery Check after the first 50 hours of machine operation.

This operator's manual is to be stored in the compartment behind the operator's seat and is attached with a lanyard. Make sure this manual is complete and in good condition. Contact your Case dealer to obtain additional manuals.

Contact your authorized Case dealer for any further information about this machine. Your Case dealer has genuine Case parts and service which is your guarantee of Quality and Performance.

Signed

Case Corporation  
Racine, WI, U.S.A.

TRIM THIS EDGE

TRIM THIS EDGE

RIGHT PAGE

TO THE OWNER \_\_\_\_\_

## RIGHT, LEFT, FRONT, AND REAR SIDES OF THE MACHINE

Right-hand and left-hand, when used in this manual, indicate the right and left sides of the machine as seen from the operator's seat. Before you drive the machine, make sure the drive sprockets are at the rear of the machine. See the following illustration for the correct TRAVEL position.



1. Forward                      2. Rearward                      3. Drive Sprocket

TRIM THIS EDGE

## IDENTIFICATION NUMBERS

Write the Product Identification Number (P.I.N.) and the engine serial number on the lines provided below. If needed, give these numbers to your Case dealer when you need parts or information for your machine. Keep a record of these numbers and your Manufacturers Statement of Origin in a safe place. If the machine is stolen, report the numbers to your local law enforcement agency.

MACHINE MODEL NUMBER \_\_\_\_\_

PRODUCT IDENTIFICATION NUMBER \_\_\_\_\_

ENGINE SERIAL NUMBER \_\_\_\_\_

### P.I.N.



This same P.I.N. is also stamped under the base of the right boom cylinder.

### Engine Serial Number

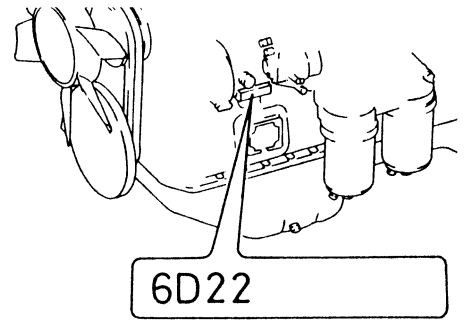

B923389J

TRIM THIS EDGE

LEFT PAGE

## MACHINE COMPONENTS

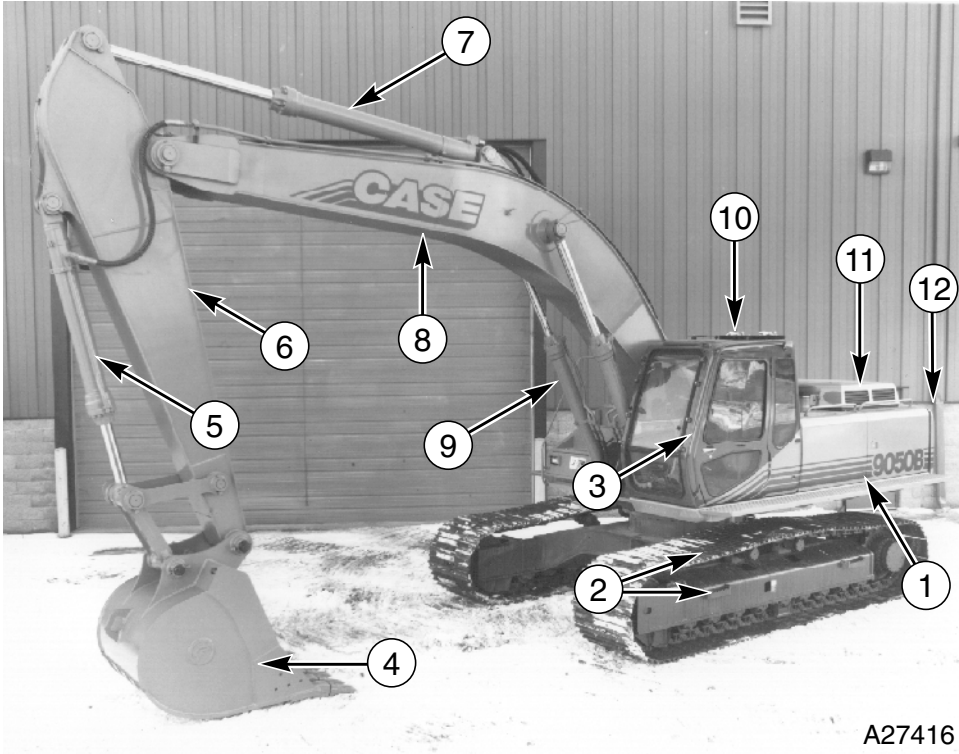

TRIM THIS EDGE

- |                    |                    |                        |
|--------------------|--------------------|------------------------|
| 1. Upper Structure | 5. Bucket Cylinder | 9. Boom Cylinders      |
| 2. Steps           | 6. Arm             | 10. Operator's Cab     |
| 3. Hand Rails      | 7. Arm Cylinder    | 11. Engine Compartment |
| 4. Bucket          | 8. Boom            | 12. Rear Counterweight |

TRIM THIS EDGE

RIGHT PAGE

## MACHINE COMPONENTS (Cont'd)

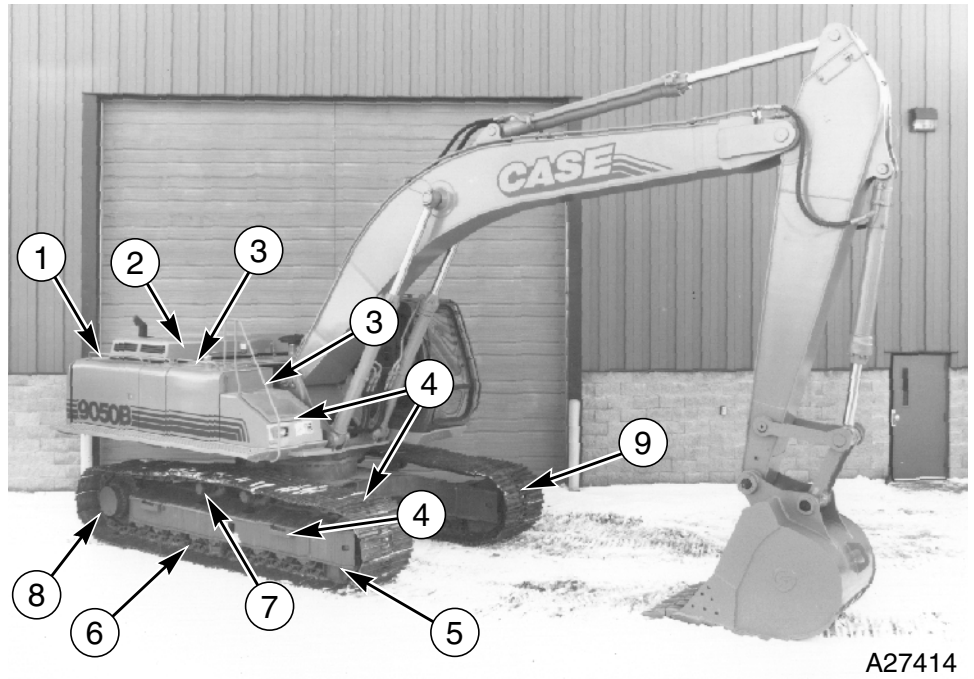

A27414

TRIM THIS EDGE

- 1. Rear Counterweight
- 2. Engine Compartment
- 3. Hand Rails

- 4. Steps
- 5. Idler
- 6. Track Rollers

- 7. Track Carrier Rollers
- 8. Drive Sprocket
- 9. Track Chain

TRIM THIS EDGE

LEFT PAGE



## SAFETY / DECALS / HAND SIGNALS



### SAFETY RULES



Most accidents involving machine operation and maintenance can be avoided by following basic rules and precautions. Read and understand all the safety messages in this manual, the EMI Safety Manual, and the safety decals on the machine before you operate or service the machine. See your Authorized Case dealer or the Case Corporation if you have any questions.

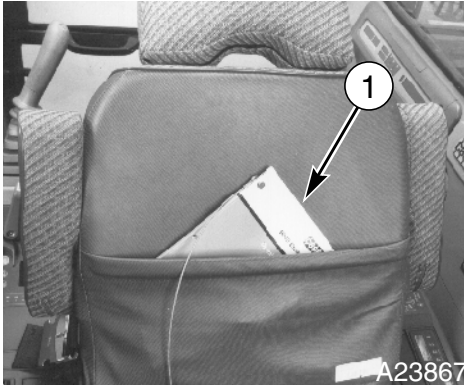

#### *1. Operator's Manual and EMI Safety Manual Storage*

Safety messages in this section point out situations which can be encountered during the normal operation and maintenance of your machine. These safety messages also give possible ways of dealing with these conditions.

Additional safety messages appear in the manual to indicate specific safety hazards.

READ THIS MANUAL COMPLETELY and make sure you understand the characteristics of speed, stability, steering, and operation of this machine.

Do not remove this manual or the safety manual from this machine. See your Case dealer for additional manuals. Also see the inside of the rear cover of this manual for detailed information for ordering manuals.

The safety information given in this manual does not replace safety codes, insurance regulations, or federal, state/provincial, or local laws. Make sure your machine has the correct equipment according to these rules or laws.

TRIM THIS EDGE

SAFETY/DECALS/HAND SIGNALS



**BEFORE OPERATION**



- To avoid getting caught in the machine, avoid loose fitting clothing, loose or uncovered long hair, jewelry and loose personal articles.
- Different jobs will require different protective equipment. Items such as hard hats, protective shoes, heavy gloves, reflector type vests, respirators, ear protection, and eye protection can be required. Before you start the job, determine what protective equipment is required. Use this equipment at all times.
- Be prepared for emergencies. Always have a first aid kit and a working fire extinguisher with you and know how to use each. See page 127 for fire extinguisher inspection, service, etc.
- Know the hand signals used on your job. Follow the instructions of the flagman, signs, markers, etc. See pages 25 and 26 for hand signals.
- Check that all doors, guards, and covers are installed correctly and closed.
- Foreign material or grease on the steps and hand rails can cause an accident. Keep the steps and hand rails clean.
- Stay away from hazardous areas such as ditches, overhangs, etc. Walk around the work area and look for hazards before you start.
- Before you operate at night, check that all lamps illuminate.
- The secondary exit on this machine is the rear window or the roof hatch.
- To avoid falling, always face the machine and use the hand rails and steps when getting on or getting off. Do not rush.

TRIM THIS EDGE

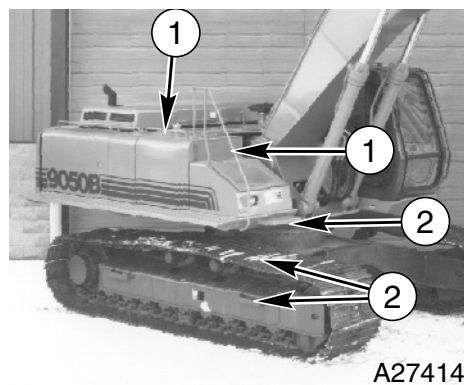
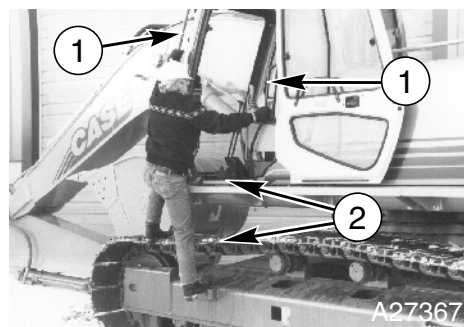
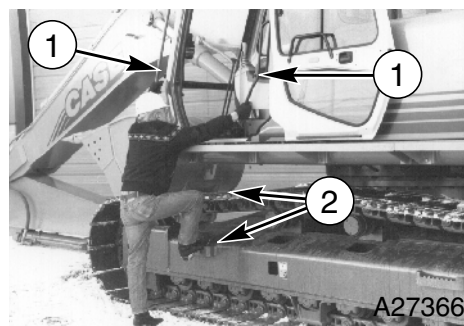

1. Hand Rails 2. Steps

TRIM THIS EDGE

LEFT PAGE