

550G CRAWLER

Operator's Manual

Bur 9-26012





This safety alert symbol indicates important safety messages in this manual. When you see this symbol, carefully read the message that follows and be alert to the possibility of personal injury or death.

M171B

Safety Decals on this machine use the words, **Danger**, **Warning** or **Caution**, which are defined as follows:

- **DANGER:** Indicates an immediate hazardous situation which, if not avoided, will result in death or serious injury. The color associated with Danger is RED.
- **WARNING:** Indicates a potentially hazardous situation which, if not avoided will result in serious injury. The color associated with Warning is ORANGE.
- **CAUTION:** Indicates a potentially hazardous situation which, if not avoided, can result in injury. It can also be used to alert against unsafe practices. The color associated with Caution is YELLOW.



WARNING

IMPROPER OPERATION OF THIS MACHINE CAN CAUSE INJURY OR DEATH. BEFORE USING THIS MACHINE, MAKE CERTAIN THAT EVERY OPERATOR:

- Is instructed in safe and proper use of the machine.
- Reads and understands the Manual(s) pertaining to the machine.
- Reads and understands ALL Safety Decals on the machine.
- Clears the area of other persons.
- Learns and practices safe use of machine controls in a safe, clear area before operating on a job site.

It is your responsibility to observe pertinent laws and regulations and follow Case Corporation instructions on machine operation and maintenance.

TABLE OF CONTENTS

TO THE OWNER	1
REGULATIONS	2
AFTER DELIVERY CHECK	2
RIGHT, LEFT, FRONT AND REAR SIDES OF THE MACHINE	2
IDENTIFICATION NUMBERS	3
MACHINE COMPONENTS	5
 SAFETY/DECALS/HAND SIGNALS	 7
SAFETY RULES	7
BEFORE OPERATION	8
MACHINE OPERATION	9
PARKING THE MACHINE	10
FIRE EXTINGUISHER	10
BURN PREVENTION	11
HAZARDOUS CHEMICALS	11
FIRE OR EXPLOSION PREVENTION	12
MAINTENANCE	13
DUCTILE IRON	13
SAFETY DECALS	14
HAND SIGNALS	18
 INSTRUMENTS/CONTROLS	 21
INSTRUMENT PANEL	21
TRANSMISSION CONTROLS, ENGINE HAND THROTTLE AND HORN BUTTON	25
BACK-UP ALARM	27
FUEL GAUGE	27
FOOT THROTTLE, STEERING AND BRAKE PEDAL	28
DECELERATOR	29
TRANSMISSION RANGE SHIFT PEDALS	29
DOZER BLADE CONTROL LEVER	30
RIPPER CONTROL LEVER	32
OPERATORS SEAT	33
OPERATORS SEAT BELT	34
 OPERATING INSTRUCTIONS 35	
RUN-IN PERIOD OF A NEW MACHINE	35
ENGINE OPERATION	36
CRAWLER OPERATION	39
TOWING A DISABLED CRAWLER	44
TRANSPORTING THE MACHINE	47
OPERATING IN HOT WEATHER	48
OPERATING IN COLD WEATHER	49
DOZER OPERATION	54
RIPPER OPERATING TIPS	59
TRACK SYSTEMS	60

TRIM THIS EDGE

LUBRICATION/FILTERS/FLUIDS	77
GENERAL SAFETY BEFORE YOU SERVICE	77
SYSTEMGARD LUBRICATION ANALYSIS PROGRAM	78
ENGINE HOURMETER	79
FLUIDS AND LUBRICANTS	80
LUBRICATION/MAINTENANCE CHART	81, 82
GREASE FITTINGS	83
ACCESS DOORS	85
ENGINE LUBRICATION	86
ENGINE SERVICE	87
AIR FILTER SYSTEM	90
ENGINE COOLING SYSTEM	94
DIESEL FUEL SYSTEM	97
HYDRAULIC SYSTEM	101
TRANSMISSION	105
FINAL DRIVES	108
MAINTENANCE/ADJUSTMENTS	109
ETHER STARTING FLUID CAN	109
TRANSMISSION CONTROL LEVER ADJUSTMENT	110
REVERSIBLE FAN POSITIONS (If Equipped)	111
ROLL-OVER PROTECTIVE STRUCTURE	112
BRAKE WEAR CHECK	115
SPARK ARRESTER MUFFLER (If Equipped)	116
MACHINE CLEANING	116
ELECTRICAL SYSTEM	117
BATTERY SERVICE	117
WORK LAMPS	118
ALTERNATOR WARNING LAMP	119
INSTRUMENT PANEL LAMP	119
TRANSMISSION FILTER WARNING LAMP	120
FUSES	120
STORAGE	121
MACHINE STORAGE	121
REMOVAL FROM STORAGE	122
SPECIFICATIONS	123
ENGINE SPECIFICATIONS (Non Emission)	123
ENGINE SPECIFICATIONS (Emission)	124
OPERATING DATA AND DIMENSIONS - LONG TRACK AND RUBBER TRACK CRAWLERS	126
INDEX	131
AFTER DELIVERY CHECK	139, 141

TO THE OWNER

Read this manual before you start the engine or operate the machine. If you need more information, see your dealer.

Your dealer can give you assistance with Case Corporation approved service parts. Your dealer has technicians with special training who know the best methods of repair and maintenance for your machine.



A25856



A25851

Call your dealer if you need help or information.

TO THE OWNER _____

REGULATIONS

NOTE: Local, state and national laws may regulate the disposal of various service fluids used in this equipment, such as but not limited to oils, hydraulic, battery and transmission fluids. You should be aware of and comply with any pertinent regulations in order to insure safe and proper handling and disposal of any regulated fluids.

AFTER DELIVERY CHECK

Two copies of the After Delivery Check are in the back of this manual. One copy is for you and one copy is for the dealer. Make sure that your dealer does the After Delivery Check after the first 20 hours of machine operation.

NOTE: Your cost for this check will be for filters, oil, or other accessories. If the dealer comes to your machine, there can also be a cost for the time and distance.

RIGHT, LEFT, FRONT AND REAR SIDES OF THE MACHINE

Right-hand and left-hand, when used in this manual, indicate the right and left sides of the machine as seen from the operators seat.

Basic Machine, Dozer and Ripper

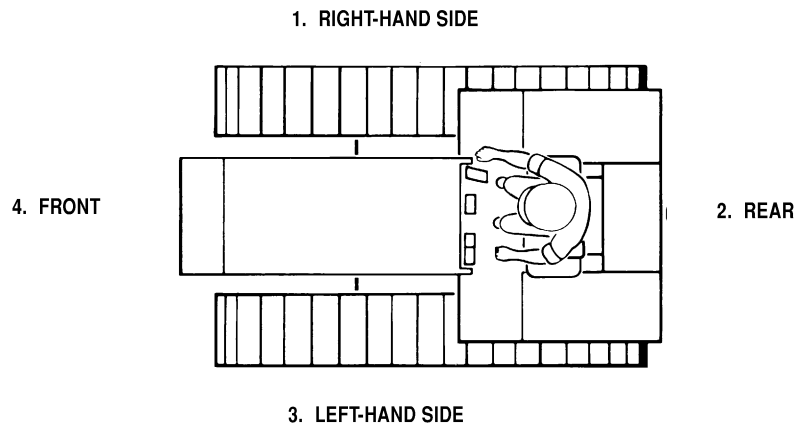

B830800J

_____ TO THE OWNER

IDENTIFICATION NUMBERS

Write your machine model number, Product Identification Number (P.I.N.) and serial numbers on the lines provided below. If needed, give these numbers to your dealer when you need parts or information for your machine.

Make a record of the numbers. Keep the record and your Manufacturer's Statement of Origin in a safe place. If the machine is stolen, report the numbers to your local law enforcement agency.

MACHINE MODEL NUMBER _____

PRODUCT IDENTIFICATION NUMBER _____

ENGINE SERIAL NUMBER _____

TRANSMISSION SERIAL NUMBER _____

TORQUE CONVERTER SERIAL NUMBER _____

ROPS CANOPY SERIAL NUMBER _____

OTHER _____

**Product Identification Number
(P.I.N.)**

Engine

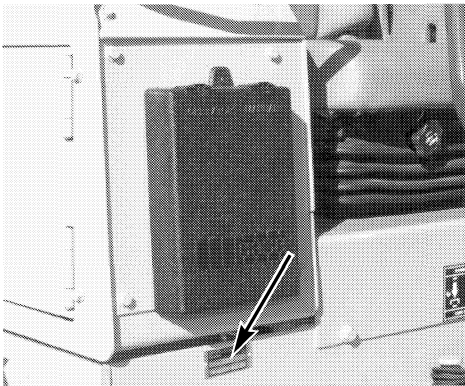

A25808

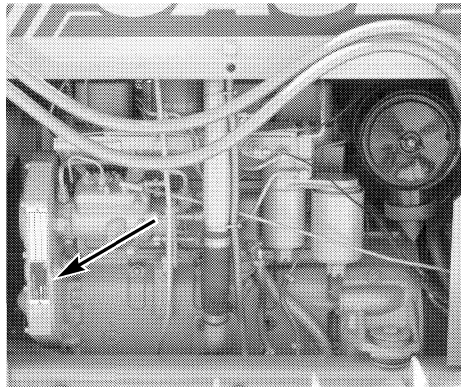

A25273A

TO THE OWNER _____

Transmission

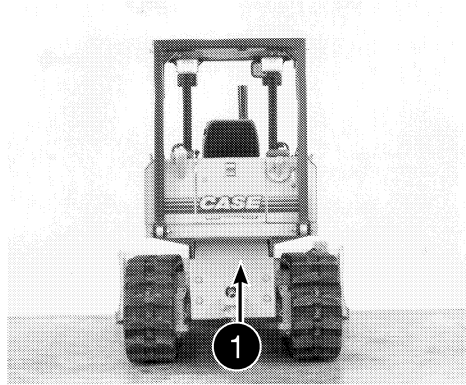

A25853

1. ON THE HOUSING BEHIND THE
GUARD

ROPS Canopy

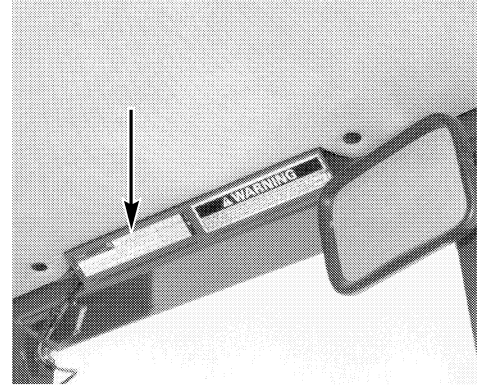

A25789

Dozer Blade

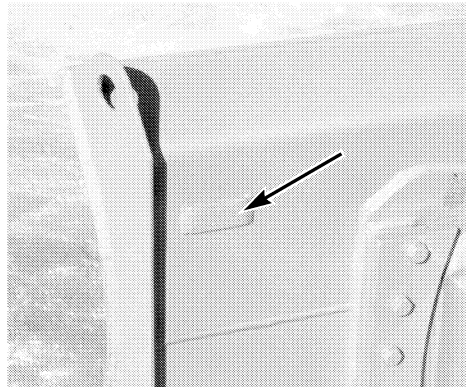

A25814

MACHINE COMPONENTS

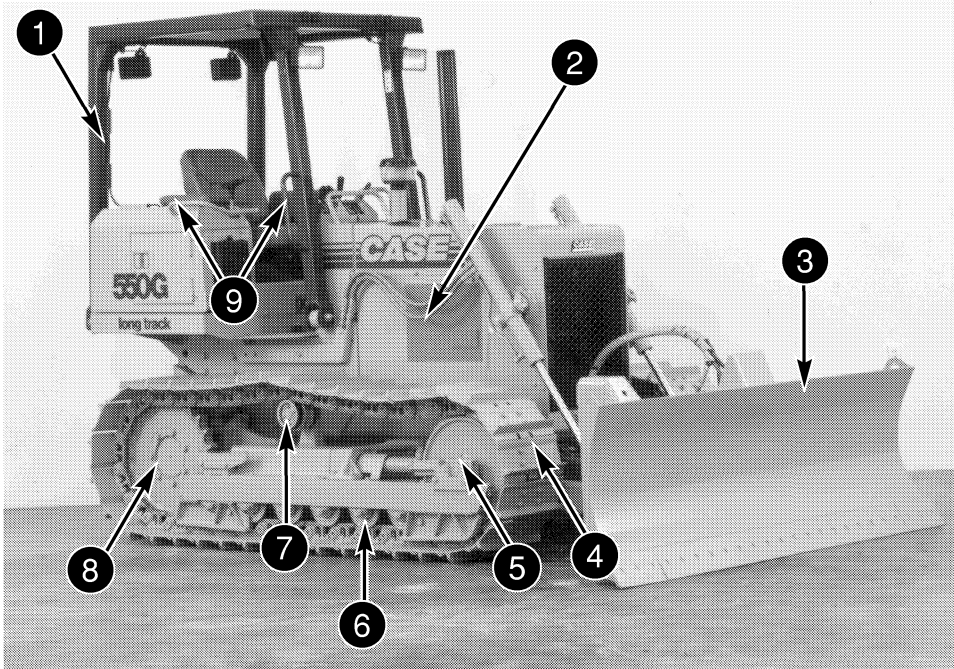

A25856

1. ROPS CANOPY
2. RIGHT ENGINE COMPARTMENT
3. BLADE
4. TRACK CHAIN
5. IDLER
6. TRACK ROLLER
7. CARRIER ROLLER
8. SPROCKET
9. HAND RAILS

TO THE OWNER _____

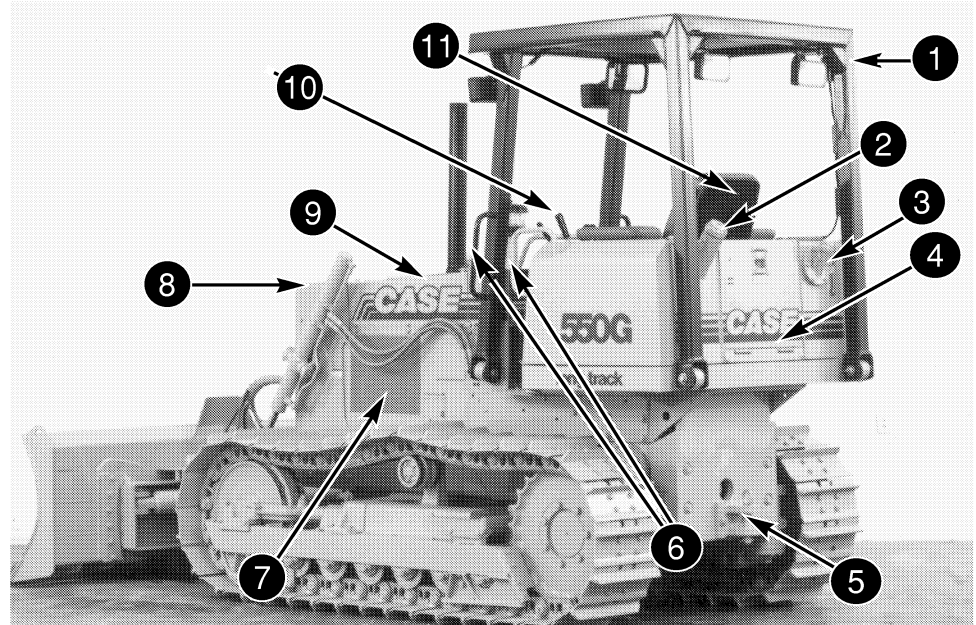

A25846

1. ROPS CANOPY
2. DIESEL FUEL FILL
3. HYDRAULIC RESERVOIR FILL AND OIL LEVEL SIGHT GAUGE
4. REAR ACCESS DOOR
5. DRAWBAR
6. HAND RAILS
7. LEFT ENGINE COMPARTMENT
8. RADIATOR CAP
9. TOP ENGINE ACCESS DOOR
10. TRANSMISSION CONTROLS
11. OPERATORS SEAT

Ripper

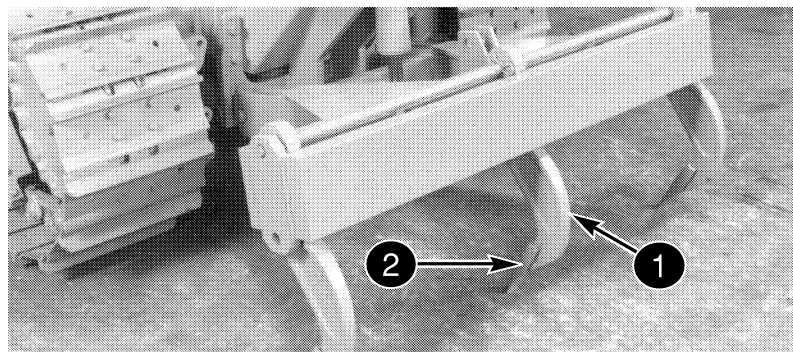

B845012

1. RIPPER TOOTH
2. TOOTH POINT