

CASE Engines 668T/M2 and 668T/E2

Service Manual

Bur 6-47950NA



REPAIR MANUAL FOR ENGINES

F4GE0684F - (668T/M2)

F4HE0684J - (668T/E2)

6-47950NA

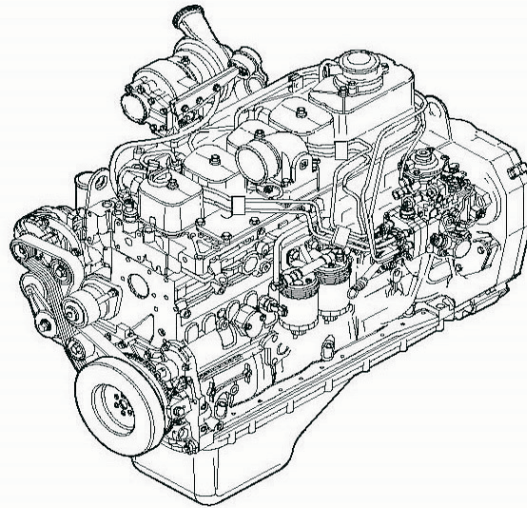

F4GE0684F

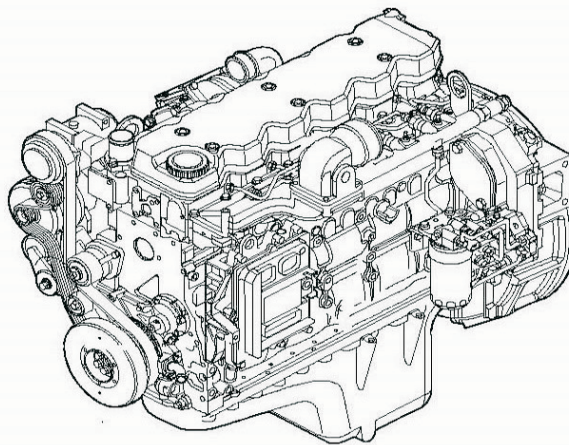

F4HE0684J

Every information, illustration and specification contained in the present manual is based on the most recent information available at the time of printing.

CNH America LLC reserves the right to modify the text at any time without prior communication.

INTRODUCTION

TO THE READER

- This manual was written for a skilled technician and contains all the technical information needed to repair this vehicle.
- Read this manual carefully for the information concerning repairing operations.

FURTHER REFERENCES**PAGE NUMBER**

- Every page carries a number on the top right corner. Every page contains the following information:

Example:: T 1 - 2 - 3

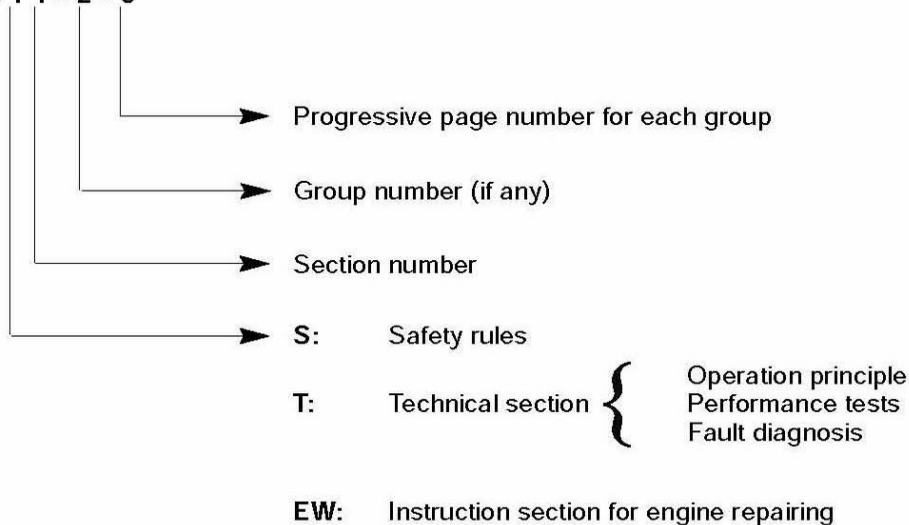
**SYMBOLS**

This manual contains safety warning symbols and indications referring to possible injuries or vehicle damages.



This symbol regards safety.

Use great care when you see this symbol because possible injuries to the personnel may occur. Strictly observe the precautions marked with this symbol.

The safety warning symbol is used also to draw attention on the weight of a component or an element. Make sure you are always using the right equipment and lifting techniques when handling heavy loads, in order to prevent injuries or damages.

ENGINES

F4GE0684F - F4HE0684J OVERHAUL

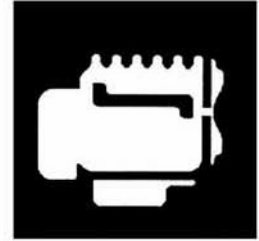

INDEX

Engine coding	EW-3-4	Engine F4GE0684F cooling	EW-3-43
Main engine features	EW-3-5	Engine F4HE0684J cooling	EW-3-44
Assembling play / specifications ...	EW-3-8	Water pump	EW-3-45
Tightening torque	EW-3-14	Engine F4GE0684F mechanic	
Tools	EW-3-15	injection feeding system	EW-3-46
Graphic indications and symbols ...	EW-3-16	Fuel prefilter	EW-3-46
General remarks	EW-3-17	Fuel filters	EW-3-46
Engine F4GE0684F	EW-3-17	Mechanic fuel pump	EW-3-47
Engine F4HE0684J	EW-3-18	Engine F4GE0684F Injection	
Description of main mechanic		assembly	EW-3-48
engine components	EW-3-19	Engine F4HE0684J fuel supply	
Crankcase	EW-3-19	system	EW-3-49
Drive shaft	EW-3-20	Engine F4HE0684J fuel system	
Drive shaft seal rings	EW-3-20	diagram	EW-3-50
Connecting rods	EW-3-21	Fuel prefilter	EW-3-51
Pistons	EW-3-22	Fuel filter	EW-3-52
Distributing shaft	EW-3-23	Mechanical feed pump	EW-3-53
Engine F4GE0684F valve control	EW-3-24	Normal operating condition	EW-3-53
Engine F4HE0684J valve control	EW-3-25	Outlet overpressure condition	EW-3-53
Engine F4GE0684F cylinder head	EW-3-26	Bleed conditions	EW-3-54
Engine F4HE0684F cylinder head	EW-3-27	High pressure pump	EW-3-54
Engine F4GE0684F valves and valve		Operating principle	EW-3-56
seats	EW-3-28	Engine F4GE0684F bench-overhaul	EW-3-59
Engine F4HE0684J valves and valve		Disassembling the engine	EW-3-59
seats	EW-3-29	Replacing the seal ring	EW-3-62
Engine F4GE0684F valve guides	EW-3-30	Removing the injection pump	EW-3-62
Engine F4HE0684J valve guides	EW-3-31	Removing the rocker arm assembly ...	EW-3-65
Valve control bridges		Repair work on cylinder cluster	EW-3-67
F4HE0684J	EW-3-31	Checks and measurements	EW-3-67
Grinding cylinder head valve seats F4HE0684J	EW-3-31	Checking the surface supporting the	
Engine flywheel	EW-3-32	head on the cylinder cluster	EW-3-68
Engine F4GE0684F auxiliary component		Valve gear	EW-3-69
drive	EW-3-33	Distributing shaft	EW-3-69
Engine F4HE0684J auxiliary component		Checking the eccentric lift and the pin	
drive	EW-3-34	alignment	EW-3-69
Engine F4GE0684F Lubrication	EW-3-35	Bushings	EW-3-70
Engine F4HE0684J Lubrication	EW-3-36	Replacing the bushings	EW-3-71
Heat exchanger	EW-3-37	Tappets	EW-3-71
Oil pump	EW-3-38	Mounting the tappets – Distributing shaft	EW-3-71
Engine F4GE0684F oil sump	EW-3-39	Drive shaft	EW-3-72
Engine F4HE0684J oil sump	EW-3-40	Measuring the journals and crankpins .	EW-3-72
Engine F4GE0684F oil vapour		Replacing the oil pump drive gears	EW-3-75
recirculation	EW-3-41	Mounting the main bearings	EW-3-75
Engine F4HE0684J oil vapour		Measuring the journal assembling play	EW-3-75
recirculation	EW-3-42	Checking the drive shaft shoulder play .	EW-3-76
		Connecting rod-piston assembly ...	EW-3-77

INDEX

Pistons	EW-3-78	Cam lift check and pin alignment check	EW-3-113
Measuring the piston diameter	EW-3-78	Bushes	EW-3-113
Piston pins	EW - 3 - 79	Head face check on the cylinder group	EW-3-115
Conditions for correct pin/piston		Timing system	EW-3-115
matching	EW-3-79	Camshaft	EW-3-115
Piston rings	EW-3-79	Bush replacement	EW-3-116
Connecting rods	EW-3-80	Tappets	EW-3-116
Bushings	EW-3-81	Fitting tappets – camshaft	EW-3-116
Checking the connecting rods	EW-3-81	Output shaft	EW-3-117
Checking the torsion	EW-3-81	Measuring journals and crankpins	EW-3-117
Checking the flexion	EW-3-81	Replacing oil pump control gear	EW-3-119
Mounting the connecting rod-piston		Fitting main bearings	EW-3-119
assembly	EW-3-82	Finding journal clearance	EW-3-119
Connecting rod-piston match	EW-3-82	Checking output shaft shoulder	
Mounting the piston rings	EW-3-82	clearance	EW-3-120
Mounting the connecting rod/piston		Connecting rod - piston assembly ..	EW-3-120
assemblies in the cylinder liners	EW-3-83	Pistons	EW-3-121
Measuring the crankpin assembling play		Measuring piston diameter	EW-3-121
EW-3-83	EW-3-83	Piston pin diameter	EW - 3 - 122
Checking piston protrusion	EW-3-84	Conditions for proper pin-piston	
Valve gear	EW-3-85	coupling	EW-3-122
Distribution gearbox case	EW-3-85	Split rings	EW-3-122
Valve timing	EW-3-85	Connecting rods	EW-3-123
Injection pump – 1st phase	EW-3-86	Bushes	EW-3-123
Timing	EW-3-86	Checking torsion	EW-3-124
Flywheel cover case	EW-3-87	Checking connecting rods	EW-3-124
Engine flywheel	EW-3-88	Checking bending	EW-3-124
Replacing the engine flywheel ring gear		Fitting connecting rod-piston assembly	
EW-3-88	EW-3-88	EW-3-124	EW-3-124
Injection pump – 2nd phase	EW-3-89	Connecting rod-piston coupling	EW-3-124
Mounting the injection pump –		Fitting split rings	EW-3-125
2nd phase	EW-3-89	Fitting connecting rod-piston assembly	
Mounting the oil and water pumps	EW-3-89	into cylinder barrels	EW-3-125
Mounting the oil sump	EW-3-90	Finding crankpin clearance	EW-3-126
Mounting the water / oil heat exchanger		Checking piston protrusion	EW-3-127
EW-3-91	EW-3-91	Timing	EW-3-128
Cylinder head	EW-3-92	Flywheel housin	EW-3-128
Removing the valves	EW-3-92	Engine flywheel	EW-3-129
Checking the cylinder head supporting		Replacing engine flywheel ring gear ...	EW-3-129
surface	EW-3-93	Cylinder head	EW-3-133
Checking the cylinder head water seal .		Removing the valves	EW-3-133
EW-3-93	EW-3-93	Removing carbon deposits, checking	
Valves	EW-3-94	and grinding valves	EW-3-135
Valve descaling, check and grinding ...		Checking cylinder head supporting	
EW-3-94	EW-3-94	surface	EW-3-134
Checking the play between the valve		Valves	EW-3-135
stem, valve guide and valve centring ..		Removing carbon deposits, checking	
EW-3-94	EW-3-94	and grinding valves	EW-3-135
Valve guide	EW-3-94	Checking clearance between valve	
Valve seats	EW-3-94	stem and valve guide and valve	
Valve seat reconditioning – replacement		centering	EW-3-135
EW-3-94	EW-3-94	Valve guide	EW-3-135
Valve springs	EW-3-96	Valve seats	EW-3-136
Mounting the cylinder head	EW-3-96	Regrinding – replacing the valve seats .	EW-3-136
Reattaching the cylinder head	EW-3-96	Valve springs	EW-3-137
Rocker arm assembly	EW-3-97	Fitting cylinder head	EW-3-138
Mounting the injectors	EW-3-98	Refitting the cylinder head	EW-3-138
Replacing the injectors	EW-3-101	Fitting injectors	EW-3-139
Removal	EW-3-101	Rods	EW-3-140
Reassembling	EW-3-101	Rocker assembly	EW-3-140
Adjusting the tappets	EW-3-103	Tappet clearance adjustment	EW-3-141
Rocker arm removal/reassembling		Harness support	EW - 3 -143
EW-3-103	EW-3-103		
Removal	EW-3-103		
Reassembling	EW-3-103		
Valve timing	EW-3-103		
Removal of EDC7 components			
F4HE0684J	EW-3-104		
Disassembly of the engine	EW-3-104		
Repair interventions	EW-3-113		
Cylinder group	EW-3-113		
Controls and measurements	EW-3-113		

ENGINE F4GE0684F - F4HE0684J OVERHAUL

Figure 1

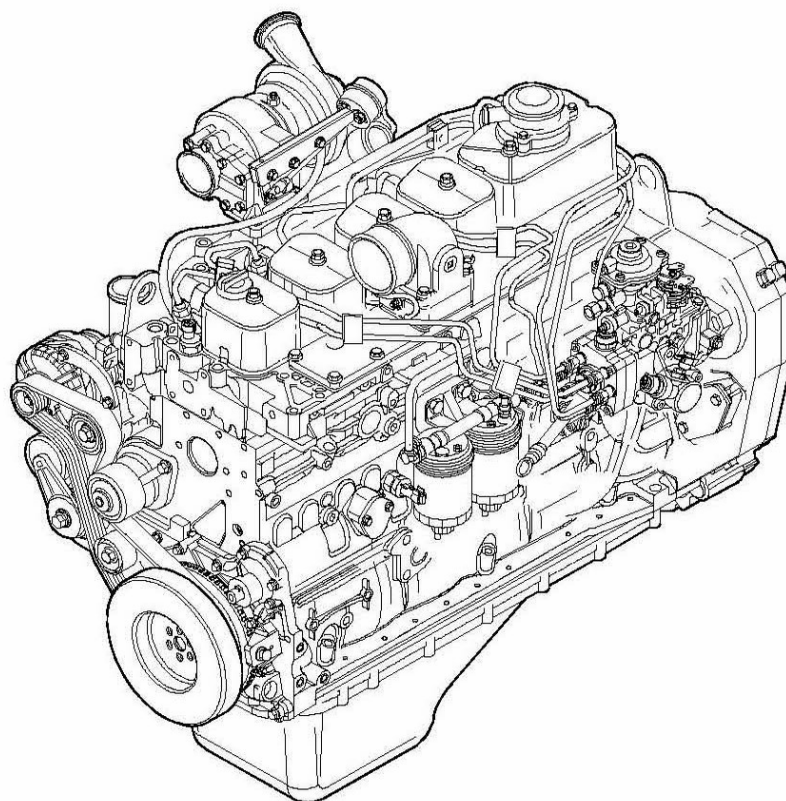

86483

ENGINE F4GE0684F

Figure 2

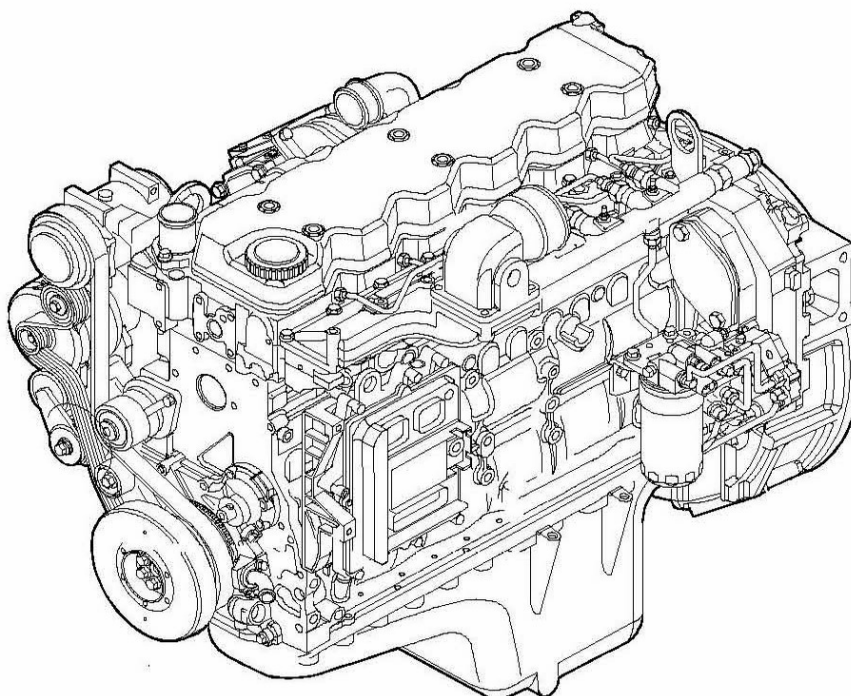

86484

ENGINE F4HE0684J

ENGINE F4GE0684F - F4HE0684J OVERHAUL

ENGINE CODING

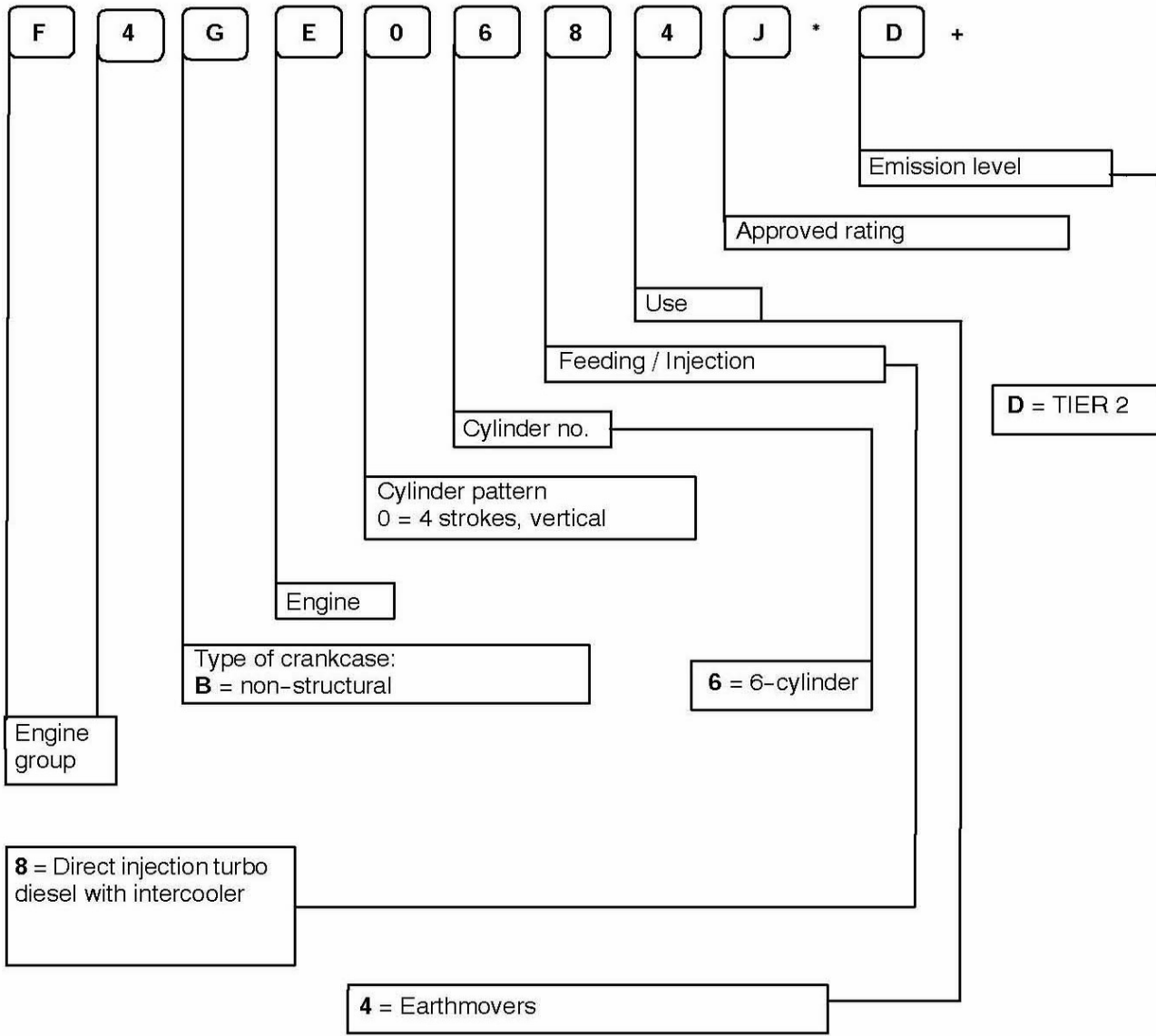

X Y Y

X = 4 in-line, 2-valve injection pump
 Y = Engine model
 X = X= 1 4-valve Common Rail

Y Y Y Y Y Y

Manufacturing sequence number

ENGINE F4GE0684F - F4HE0684J OVERHAUL

MAIN ENGINE FEATURES

A	LW130.B	LW170.B
B	F4GE0684F	F4HE0684J
C	*D601	*D100
D		
E	6728 cm ³	
F	110 kW 2000 rpm	145 kW 2000 rpm

G

Direct injection

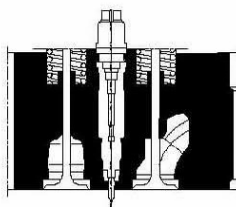

H

In-line injection pump









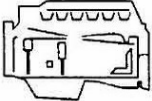
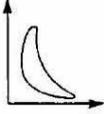
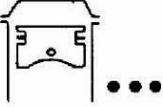
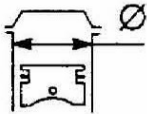
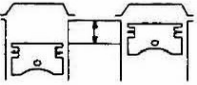
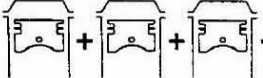

I

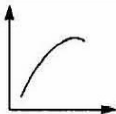
T.A.A.
(Boosted by intercooler)

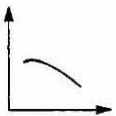



- A Wheeled loaders
- B Type of engine
- C Engine model
- D Number of cylinders
- E Total displacement
- F Max. power currently available
- G Type of injection
- H Injection system
- I Air supply system

ENGINE F4GE0684F - F4HE0684J OVERHAUL

MAIN ENGINE FEATURES

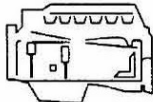
	Type	F4GE6484F	F4HE6484J	
		*D601	*D100	
	Cycle	4-stroke diesel engine		
	Feeding	Boosted by intercooler		
	Injection	Direct		
	Number of cylinders	In-line, 6-cylinder		
	Bore	mm	11042	
	Stroke	mm	132	
	Total displacement	cm ³	6728 cm ³	
	Compression ratio			
 	Max. rating	kW min ⁻¹	110 2000	145 2000
 	Max. torque	Nm (kgm) min ⁻¹	675 1400	850 1400
	No-load idle rpm	min ⁻¹	700	
	No-load peak rpm	min ⁻¹	-	
	BOOSTING Type of turbocompressor:	With intercooler HOLSET HX35W		
	LUBRICATION Oil pressure with hot engine: at idle rpm at peak rpm	bar bar	Forced by means of gear pump, pressure relief valve, oil filter 1.2 3.8	

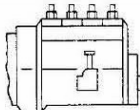
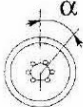
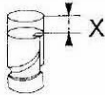
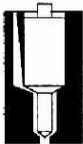
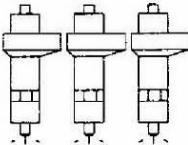
ENGINE F4GE0684F - F4HE0684J OVERHAUL

	Type	F4GE0684F	F4HE0684J
		*D601	*D100
COOLING		By fluid	
Water pump drive:		By means of belt	
Thermostat: start of opening: °C		81 ± 2	
	REFUELLING		
	Ambra Super Gold 15W40 10W30	Full filling capacity 1° litres	-
		kg	
	- engine sump	litres	-
	kg		
	- engine sump + filter	litres	
		kg	
	FEEDING Bosch-type injection	VE6/12F9000 L968	High pressure Common Rail
	Pump setting	0° ± 0°.5	
	Start of delivery	mm	1
	Type of nozzle	DSLA 145 P1174	Electro-injectors
	Injection sequence	1 - 5 - 3 - 6 - 2 - 4	
	Injection pressure bar	245 bar	250 - 1450 bar
