

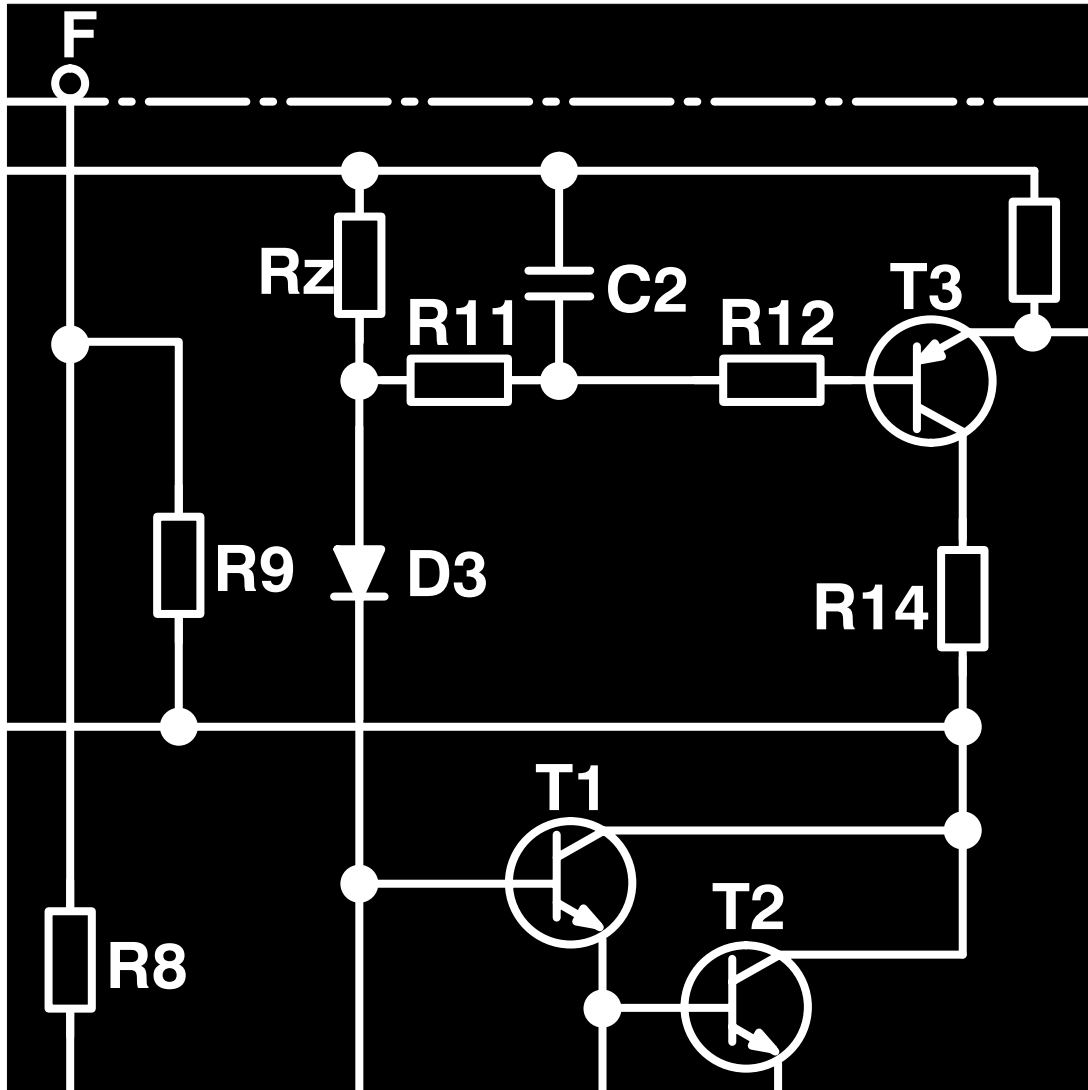

1997 BMW Z3 (E36/7)

Electrical Troubleshooting Manual

Vehicles Produced 9/96 thru 8/97





ELECTRICAL TROUBLESHOOTING MANUAL

SERIES 3 – E36/7 (Z3 Roadster)

SCHEMATICS

MODEL YEAR 1997

0100.0	INDEX	6160.1	WIPER/WASHER MODULE (WWM)
0110.0	INTRODUCTION	6167.1	HEADLIGHT WASHER (SRA)
0140.0	SYMBOLS	6169.0	WINDSHIELD WASHER JET HEATERS
0670.0	POWER DISTRIBUTION CHART	6211.0	INSTRUMENT CLUSTER
0670.1	FUSE CHART	6213.3	DIGITAL CLOCK
0670.2	POWER DISTRIBUTION	6300.0	LIGHT SWITCH DETAILS
0670.3	FUSE DETAILS	6312.0	HEADLIGHTS/FOG LIGHTS
0670.4	GROUND DISTRIBUTION	6313.0	TURN/HAZARD LIGHTS
0670.5	DATA LINK	6314.0	PARK/TAIL/UNDERHOOD LIGHTS
1210.17	ENGINE CONTROL SYSTEM MS41.1 (6-CYLINDER M52)	6320.0	LICENSE PLATE/LUGGAGE COMPARTMENT LIGHTS
1210.20	ENGINE CONTROL SYSTEM (DME M5.2, 4-CYLINDER M44)	6322.0	BACK UP LIGHTS
1230.0	CHARGING SYSTEM	6325.0	BRAKE LIGHTS
1240.0	START	6330.3	INTERIOR LIGHTS
1290.0	E-BOX FAN	6332.0	INTERIOR ACCESSORIES
2460.2	ELECTRONIC TRANSMISSION CONTROL (EGS A4S 310R)	6350.0	CRASH CONTROL MODULE
3234.0	SUPPLEMENTAL RESTRAINT SYSTEM (AIR BAG)	6424.0	REAR WINDOW DEFOGGER
3450.0	SLIP CONTROL (ABS)	6450.6	INTEGRATED HEATING- AND CLIMATE CONTROL
3450.1	SLIP CONTROL (ABS/ASC)	6510.1	RADIO/HIFI
5116.0	POWER MIRRORS	6561.0	CELLULAR TELEPHONE (PROVISIONS)
5126.0	ZKE CENTRAL LOCKING (ZV)	6571.0	CRUISE CONTROL (TEMPOMAT)
5133.0	ZKE POWER WINDOWS (FH)	6575.2	ANTI-THEFT SYSTEM (ALPINE)
5200.0	POWER SEATS	6581.3	BOARD COMPUTER (BC-LOW)
5203.0	HEATED SEATS	7000.0	COMPONENT LOCATION CHART
6100.0	CENTRAL BODY ELECTRONICS (ZKE IV)	7100.0	COMPONENT LOCATION VIEWS
6133.0	HORN	8000.0	SPLICE LOCATION VIEWS
6135.0	DRIVE-AWAY PROTECTION (EWS II)	8500.0	CONNECTOR VIEWS



INDEX

Z3

ABS CONTROL MODULE/HYDRAULIC UNIT, A202	3450.0
ABS HYDRAULIC UNIT, Y1w	3450.1-01
ABS HYDRAULIC UNIT, Y1w	3450.1-07
ABS HYDRAULIC UNIT, Y1w	3450.1-11
ABS PUMP MOTOR RELAY, K75	3450.1-00
ABS PUMP MOTOR RELAY, K75	3450.1-06
ABS PUMP MOTOR RELAY, K75	3450.1-10
ABS RELAY, K10	3450.1-00
AIR BAG GAS GENERATOR, DRIVER'S, G5	3234.0-00
AIR BAG GAS GENERATOR, PASSENGER'S, G6	3234.0-00
AIR CONDITIONING COMPRESSOR, Y2	6450.6-02
AIR CONDITIONING/RECIRCULATING SWITCH ASSEMBLY, S220	6450.6-01
AIR PUMP, Y6133	1210.17-05
AIR PUMP, Y6133	1210.20-09
ANTENNA AMPLIFIER AM/FM, N8	6510.1-00
ANTI-THEFT CONTROL MODULE (ALPINE), N12w	6575.2
ANTI-THEFT HORN (ALPINE), H1w	6575.2-01
ANTI-THEFT SYSTEM (ALPINE)	6575.2
ASC DIODE, V7	3450.1-00
ASC SWITCH, S6	3450.1-02
ASC SWITCH, S6	3450.1-05
ASC SWITCH, S6	3450.1-09
AUTOMATIC TRANSMISSION RANGE SWITCH, S3	2460.2-08
AUXILIARY FAN MOTOR, M9	6450.6-03
AUXILIARY FAN MOTOR, M9	6450.6-04
AUXILIARY FUSE BOX, P97	0670.2-02
AUXILIARY THROTTLE POSITION MOTOR (ADS), M93	3450.1-02
AUXILIARY THROTTLE POSITION MOTOR (ADS), M93	3450.1-09
AUXILIARY THROTTLE POSITION SENSOR, R31	3450.1-04
AUXILIARY THROTTLE POSITION SENSOR, R31	3450.1-09
AUXILIARY TURN LIGHT, LEFT FRONT, H9	6313.0-02
AUXILIARY TURN LIGHT, RIGHT FRONT, H8	6313.0-02
B+ JUMP START JUNCTION POINT, G6430	0670.2-00
B+ JUMP START JUNCTION POINT, G6430	0670.2-01

BACK UP LIGHT, LEFT, H27	6322.0-00
BACK UP LIGHT, RIGHT, H28	6322.0-00
BACK UP LIGHTS	6322.0-00
BATTERY, G1	0670.2-00
BATTERY, G1	0670.2-01
BLOWER MOTOR, M30	6450.6-00
BLOWER RELAY, K4	6450.6-00
BLOWER RESISTORS, R11	6450.6-00
BLOWER SWITCH, S75	6450.6-00
BOARD COMPUTER (BC-LOW)	6581.3-00
BOARD COMPUTER (BC-LOW), A35y	6581.3-00
BRAKE FLUID LEVEL SWITCH, B18	6211.0-00
BRAKE LIGHT SWITCH, S30	6325.0-00
BRAKE LIGHT, LEFT, H24	6325.0-00
BRAKE LIGHTS	6325.0-00
BRAKE PAD SENSOR, LEFT FRONT, B16	6211.0-01
BRAKE PAD SENSOR, RIGHT REAR B17	6211.0-01
CAMSHAFT POSITION SENSOR (CYLINDER IDENTIFICATION), B6204	1210.17-06
CD CHANGER, N22	6510.1
CELLULAR TELEPHONE (PROVISIONS)	6561.0-00
CENTRAL BODY ELECTRONICS (ZKE IV)	6100.0
CHARCOAL FILTER SHUT-OFF VALVE, B6247	1210.17-10
CHARCOAL FILTER SHUT-OFF VALVE, B6247	1210.20-02
CHARGING SYSTEM	1230.0-00
CHIME MODULE, H10	6211.0-05
CLUTCH SWITCH, S32	6571.0-01
COMBINATION SWITCH, S7	6313.0-00
COMPONENT LOCATION CHART	7000.0
COMPONENT LOCATION VIEWS	7100.0
COMPRESSOR CONTROL RELAY, K19	6450.6-02
CONNECTOR VIEWS	8500.0
CONTACT RING, C101	3234.0-00
CONVERTIBLE TOP ACTUATING SWITCH, S143	5430.0-00
CONVERTIBLE TOP END-POSITION MICRO SWITCH, S164 ..	5430.0-00



INDEX

Z3

CONVERTIBLE TOP MOTOR, M101	5430.0-00
CONVERTIBLE TOP RELAY I (CLOSE), K18363	5430.0-00
CONVERTIBLE TOP RELAY II (OPEN), K18364	5430.0-00
CRANKSHAFT POSITION/RPM SENSOR, B6203	1210.17-06
CRANKSHAFT POSITION/RPM SENSOR, B6203	1210.20-04
CRASH CONTROL MODULE	6350.0
CRASH CONTROL MODULE, N17	6350.0-01
CRUISE CONTROL (TEMPOMAT)	6571.0
CRUISE CONTROL ACTUATOR (TEMPOMAT), M25	6571.0-01
CRUISE CONTROL MODULE (TEMPOMAT), A8	6571.0
CRUISE CONTROL SWITCH, S28	6571.0-00
DATA LINK	0670.5
DATA LINK CONNECTOR, D100	0670.5
DIGITAL CLOCK	6213.3-00
DIGITAL CLOCK, A110	6213.3-00
DOOR JAMB SWITCH, DRIVER'S, S14	5126.0-01
DOOR JAMB SWITCH, PASSENGER'S, S13	5126.0-01
DOOR LOCK MOTOR, DRIVER'S, M12	5126.0-02
DOOR LOCK MOTOR, PASSENGER'S, M13	5126.0-02
DOOR LOCK SWITCH, DRIVER'S, S47	5126.0-00
DOOR LOCK SWITCH, PASSENGER'S, S49	5126.0-00
DOUBLE TEMPERATURE SWITCH, S36y	6450.6-04
DRIVE-AWAY PROTECTION (EWS II)	6135.0
DUAL TEMPERATURE SENSOR (COOLANT TEMPERATURE), B6256	1210.17-02
E-BOX FAN	1290.0-00
E-BOX FAN, M6506	1290.0-00
ELECTRO-MECHANICAL CONVERTIBLE TOP	5430.0
ELECTRONIC IMMOBILIZER CONTROL MODULE (EWS II), A836	6135.0-00
ELECTRONIC TRANSMISSION CONTROL (EGS A4S 310R)	2460.2
ENGINE CONTROL MODULE (DME), A6000	1210.17
ENGINE CONTROL MODULE (DME), A6000	1210.20
ENGINE CONTROL MODULE RELAY, K6300	1210.17-00
ENGINE CONTROL MODULE RELAY, K6300	1210.20-00

ENGINE CONTROL SYSTEM (DME M5.2, 4-CYLINDER M44)	1210.20
ENGINE CONTROL SYSTEM MS41.1 (6-CYLINDER M52)	1210.17
ENGINE COOLANT TEMPERATURE SENSOR, B6232	1210.17-02
ENGINE COOLANT TEMPERATURE SENSOR, B6232	1210.20-05
ENGINE COOLANT TEMPERATURE SENSOR, B6232	6211.0-02
ENGINE COOLANT TEMPERATURE SENSOR, B6236	1210.17-02
ENGINE HOOD SWITCH, S21w	6575.2-00
EVAPORATIVE EMISSION VALVE, Y6120	1210.17-05
EVAPORATIVE EMISSION VALVE, Y6120	1210.20-01
EVAPORATOR CONTROLLER, S221	6450.6-01
EVAPORATOR TEMPERATURE SENSOR, B14	6450.6-01
FOG LIGHT SWITCH, S10	6312.0-00
FOG LIGHT, LEFT, E26	6312.0-00
FRESH AIR RECIRCULATION MOTOR, M111	6450.6-01
FRONT ASHTRAY LIGHT, E25	6300.0-01
FRONT ASHTRAY LIGHT, E25	6332.0-00
FRONT CIGAR LIGHTER LIGHT, E29	6300.0-01
FRONT CIGAR LIGHTER LIGHT, E29	6332.0-00
FRONT CIGAR LIGHTER, E28	6332.0-00
FRONT FOG LIGHT RELAY, K47	6312.0-00
FRONT POWER DISTRIBUTION BOX, P90	0670.2
FUEL CHANGEOVER VALVE, Y6263	1210.20-09
FUEL INJECTION VALVE, CYL. 1, Y6101	1210.17-01
FUEL INJECTION VALVE, CYL. 1, Y6101	1210.20-01
FUEL INJECTION VALVE, CYL. 2, Y6102	1210.17-01
FUEL INJECTION VALVE, CYL. 2, Y6102	1210.20-01
FUEL INJECTION VALVE, CYL. 3, Y6103	1210.17-01
FUEL INJECTION VALVE, CYL. 3, Y6103	1210.20-01
FUEL INJECTION VALVE, CYL. 4, Y6104	1210.17-01
FUEL INJECTION VALVE, CYL. 4, Y6104	1210.20-01
FUEL INJECTION VALVE, CYL. 5, Y6105	1210.17-01
FUEL INJECTION VALVE, CYL. 6, Y6106	1210.17-01
FUEL PUMP RELAY, K6301w	1210.17-04
FUEL PUMP RELAY, K6301w	1210.20-02
FUEL PUMP, M2	1210.17-04

03/98

0100.0-01

1997



INDEX

Z3

FUEL PUMP, M2	1210.20-02
FUEL SENSOR, B6y	6211.0-04
FUEL TANK PRESSURE SENSOR, B65	1210.17-10
FUEL TANK PRESSURE SENSOR, B65	1210.20-05
FUSE CHART	0670.1
FUSE DETAILS	0670.3
GENERATOR, G6509	1230.0-00
GROUND DISTRIBUTION	0670.4
HALL EFFECT CAMSHAFT SENSOR, B6209	1210.20-04
HARD TOP CONNECTOR 1, E99	6424.0-00
HAZARD FLASHER RELAY, K16	6313.0-00
HAZARD SWITCH, S18	6313.0-01
HEADLIGHT WASHER (SRA)	6167.1-00
HEADLIGHT, LEFT, E7	6312.0-01
HEADLIGHT, RIGHT, E8	6312.0-01
HEADLIGHT/FOG LIGHT WASHER PUMP, M7	6160.1-00
HEADLIGHT/FOG LIGHT WASHER PUMP, M7	6167.1-00
HEADLIGHTS/FOG LIGHTS	6312.0
HEAT/A/C CONTROL PANEL ILLUMINATION, E105	6300.0-02
HEAT/A/C CONTROL PANEL ILLUMINATION, E106	6300.0-02
HEATED SEATS	5203.0-00
HIFI AMPLIFIER, A18	6510.1
HIGH BEAM LIGHT RELAY, K46	6312.0-01
HIGH BEAM LIGHT, LEFT, E11	6312.0-01
HIGH BEAM LIGHT, RIGHT, E12	6312.0-01
HIGH LEVEL STOP LIGHT, H34	6325.0-00
HIGH RANGE SPEAKER, LEFT FRONT, H59	6510.1-01
HIGH RANGE SPEAKER, RIGHT FRONT, H50	6510.1-02
HIGH SPEED RELAY, K22	6450.6-03
HIGH SPEED RELAY, K22	6450.6-04
HORN	6133.0-00
HORN RELAY, K2	6133.0-00
HORN SWITCH, S4	6133.0-00
HORN, LEFT, H2	6133.0-00
HORN, RIGHT, H3	6133.0-00

HOT FILM AIR MASS METER, B6207	1210.17-05
HOT FILM AIR MASS METER, B6217	1210.20-06
IDLE SPEED CONTROL VALVE, Y6130	1210.20-01
IGNITION COIL, CYL. 1, T6151	1210.17-03
IGNITION COIL, CYL. 1, T6151	1210.20-03
IGNITION COIL, CYL. 2, T6152	1210.17-03
IGNITION COIL, CYL. 2, T6152	1210.20-03
IGNITION COIL, CYL. 3, T6153	1210.17-03
IGNITION COIL, CYL. 3, T6153	1210.20-03
IGNITION COIL, CYL. 4, T6154	1210.17-03
IGNITION COIL, CYL. 4, T6154	1210.20-03
IGNITION COIL, CYL. 5, T6155	1210.17-03
IGNITION COIL, CYL. 6, T6156	1210.17-03
IGNITION SWITCH, S2	0670.2-04
INDEX	0100.0
INSTRUMENT CLUSTER	6211.0
INSTRUMENT CLUSTER, A2w	6211.0
INTAKE AIR RESONANCE CHANGEOVER VALVE, Y6131	1210.20-01
INTAKE AIR TEMPERATURE SENSOR, B6205	1210.17-02
INTAKE AIR TEMPERATURE SENSOR, B6205	1210.20-05
INTEGRATED HEATING- AND CLIMATE CONTROL	6450.6
INTERIOR ACCESSORIES	6332.0-00
INTERIOR LIGHT, FRONT LEFT, E800	6330.3-00
INTERIOR LIGHTS	6330.3-00
INTERMEDIATE PRESSURE SWITCH, B9	6450.6-03
INTERMEDIATE PRESSURE SWITCH, B9	6450.6-04
INTRODUCTION	0110.0
JET HEATER THERMOSWITCH, S198	6169.0-00
JUMPER PLUG, B900	6571.0-01
KICK-DOWN SWITCH, S8507	2460.2-02
KICK-DOWN SWITCH, S8507	2460.2-06
KNOCK SENSOR, B6240	1210.17-06
KNOCK SENSOR, B6240	1210.20-05
LICENSE PLATE LIGHT, LEFT, E43	6320.0-00
LICENSE PLATE LIGHT, RIGHT, E44	6320.0-00



INDEX

Z3

LICENSE PLATE/LUGGAGE COMPARTMENT LIGHTS	6320.0-00
LIGHT ASSEMBLY, LEFT REAR, E16	0670.4-12
LIGHT ASSEMBLY, RIGHT REAR E17	0670.4-12
LIGHT SWITCH DETAILS	6300.0
LIGHT SWITCH, S8	6300.0-00
LOW BEAM LIGHT RELAY, K48	6312.0-01
LOW BEAM LIGHT, LEFT, E13	6312.0-01
LOW BEAM LIGHT, RIGHT, E14	6312.0-01
LOW RANGE SPEAKER, LEFT FRONT, H58	6510.1-02
LOW RANGE SPEAKER, LEFT REAR, H57	6510.1-01
LOW RANGE SPEAKER, RIGHT FRONT, H51	6510.1-02
LOW RANGE SPEAKER, RIGHT REAR H52	6510.1-01
LUGGAGE COMPARTMENT LIGHT SWITCH, S826	6320.0-00
MARKER LIGHT, LEFT FRONT, E21	6314.0-01
MARKER LIGHT, RIGHT FRONT, E22	6314.0-01
MIDRANGE SPEAKER, LEFT FRONT, H55	6510.1-01
MIDRANGE SPEAKER, RIGHT FRONT, H54	6510.1-02
MIRROR CONTROL SWITCH, S17	5116.0-00
MIRROR, DRIVER'S SIDE, Y5	5116.0-01
MIRROR, PASSENGER'S SIDE, Y6	5116.0-01
NORMAL SPEED RELAY, K21	6450.6-03
NORMAL SPEED RELAY, K21	6450.6-04
OBD II CONNECTOR, D110	0670.5-05
OIL PRESSURE SWITCH, B6231	6211.0-02
ON-BOARD COMPUTER TEMPERATURE SENSOR, B21	6581.3-00
OXYGEN SENSOR (BEHIND CATALYTIC CONVERTER), B62002	1210.20-04
OXYGEN SENSOR (BEHIND CATALYTIC CONVERTER), B6220y	1210.17-04
OXYGEN SENSOR (IN FRONT OF CATALYTIC CONVERTER), B62001	1210.20-04
OXYGEN SENSOR (IN FRONT OF CATALYTIC CONVERTER), B6210y	1210.17-04
PARK BRAKE SWITCH, S31	6211.0-00
PARK LIGHT, LEFT, E15	6314.0-01

PARK LIGHT, RIGHT, E19	6314.0-01
PARK/TAIL/UNDERHOOD LIGHTS	6314.0
POWER DISTRIBUTION	0670.2
POWER DISTRIBUTION CHART	0670.0
POWER MIRRORS	5116.0
POWER SEATS	5200.0
POWER WINDOW SWITCH, DRIVER'S, S126y	5133.0-01
POWER WINDOW SWITCH, PASSENGER'S, S127y	5133.0-01
PRESSURE SWITCH, B8y	6450.6-03
PRESSURE SWITCH, B8y	6450.6-04
PRESSURE SWITCH, B9508	6450.6-03
PRESSURE SWITCH, B9508	6450.6-04
PROGRAM SWITCH, S8503	2460.2-03
PROGRAM SWITCH, S8503	2460.2-07
PYROTECHNICAL BELT TENSIONER, DRIVER'S SIDE, G12	3234.0-00
PYROTECHNICAL BELT TENSIONER, PASSENGER'S SIDE, G13	3234.0-00
RADIO ANTI-THEFT SWITCH, S20w	6575.2-00
RADIO, N9	6510.1
RADIO/HIFI	6510.1
REAR DEFOGGER I, E9	6424.0-00
REAR LEFT MID-HIGH RANGE SPEAKER, H55z	6510.1-01
REAR RIGHT MID-HIGH RANGE SPEAKER, H54z	6510.1-01
REAR WINDOW DEFOGGER	6424.0-00
REAR WINDOW DEFOGGER SWITCH, S76	6424.0-00
REAR WOOFER, H500	6510.1-01
RESISTOR, R8554	0670.4-07
REVERSING LIGHT SWITCH, S8511	6322.0-00
RIGHT BRAKE LIGHT, RIGHT, H31	6325.0-00
RIGHT FOG LIGHT, RIGHT, E27	6312.0-00
SEAT BELT SWITCH, DRIVER'S, S58	3234.0-01
SEAT BELT SWITCH, PASSENGER'S, S59	3234.0-01
SEAT CONTROL SWITCH, DRIVER'S SEAT, S51	5200.0-00
SEAT CONTROL SWITCH, DRIVER'S SEAT, S51	5200.0-02

03/98

0100.0-03

1997



INDEX

Z3

SEAT CONTROL SWITCH, DRIVER'S SEAT, S51	5200.0-04
SEAT CONTROL SWITCH, DRIVER'S SEAT, S51	5200.0-06
SEAT CONTROL SWITCH, PASSENGER'S SEAT, S56	5200.0-01
SEAT CONTROL SWITCH, PASSENGER'S SEAT, S56	5200.0-03
SEAT CONTROL SWITCH, PASSENGER'S SEAT, S56	5200.0-05
SEAT CONTROL SWITCH, PASSENGER'S SEAT, S56	5200.0-07
SEAT HEATER SWITCH, DRIVER'S SEAT, S53	5203.0-00
SEAT HEATER SWITCH, PASSENGER'S SEAT, S54	5203.0-00
SEAT HEATER, DRIVER'S, E57	5203.0-00
SEAT HEATER, PASSENGER'S, E58	5203.0-00
SEAT HEIGHT MOTOR, DRIVER'S, M52	5200.0-00
SEAT HEIGHT MOTOR, DRIVER'S, M52	5200.0-02
SEAT HEIGHT MOTOR, DRIVER'S, M52	5200.0-04
SEAT HEIGHT MOTOR, DRIVER'S, M52	5200.0-06
SEAT HEIGHT MOTOR, PASSENGER'S, M59	5200.0-01
SEAT HEIGHT MOTOR, PASSENGER'S, M59	5200.0-03
SEAT HEIGHT MOTOR, PASSENGER'S, M59	5200.0-05
SEAT HEIGHT MOTOR, PASSENGER'S, M59	5200.0-07
SEAT LENGTH ADJUST CUT-OFF RELAY, DRIVER'S, K921	5200.0-02
SEAT LENGTH ADJUST CUT-OFF RELAY, DRIVER'S, K921	5200.0-06
SEAT LENGTH ADJUST CUT-OFF RELAY, PASSENGER'S, K911	5200.0-03
SEAT LENGTH ADJUST CUT-OFF RELAY, PASSENGER'S, K911	5200.0-07
SEAT LIMIT SWITCH, DRIVER'S, S910	5200.0-02
SEAT LIMIT SWITCH, DRIVER'S, S910	5200.0-06
SEAT LIMIT SWITCH, PASSENGER'S, S911	5200.0-03
SEAT LIMIT SWITCH, PASSENGER'S, S911	5200.0-07
SEAT MAT, I1008	3234.0-02
SEAT MOVEMENT MOTOR, DRIVER'S, M51	5200.0-00
SEAT MOVEMENT MOTOR, DRIVER'S, M51	5200.0-02
SEAT MOVEMENT MOTOR, DRIVER'S, M51	5200.0-04
SEAT MOVEMENT MOTOR, DRIVER'S, M51	5200.0-06
SEAT MOVEMENT MOTOR, PASSENGER'S, M60	5200.0-01
SEAT MOVEMENT MOTOR, PASSENGER'S, M60	5200.0-03

SEAT MOVEMENT MOTOR, PASSENGER'S, M60	5200.0-05
SEAT MOVEMENT MOTOR, PASSENGER'S, M60	5200.0-07
SEAT OCCUPANCY DETECTOR, A113	3234.0-02
SEAT TILT ADJUST CUT-OFF RELAY, DRIVER'S, K920	5200.0-02
SEAT TILT ADJUST CUT-OFF RELAY, DRIVER'S, K920	5200.0-06
SEAT TILT ADJUST CUT-OFF RELAY, PASSENGER'S, K910	5200.0-03
SEAT TILT ADJUST CUT-OFF RELAY, PASSENGER'S, K910	5200.0-07
SEATBACK HEATER, DRIVER'S, E56	5203.0-00
SEATBACK HEATER, PASSENGER'S, E59	5203.0-00
SECONDARY AIR PUMP RELAY, K6304	1210.17-05
SECONDARY AIR PUMP RELAY, K6304	1210.20-09
SECONDARY AIR PUMP VALVE, Y6163	1210.17-05
SECONDARY AIR PUMP VALVE, Y6163	1210.20-09
SHIFT-LOCK, Y19	2460.2-02
SHIFT-LOCK, Y19	2460.2-05
SIDE LIGHT SWITCH, S408	6330.3-00
SLIP CONTROL (ABS)	3450.0
SLIP CONTROL (ABS/ASC)	3450.1
SLIP CONTROL MODULE (ABS/ASC), A52	3450.1
SOLENOID VALVE ("RUNNING LOSSES"), Y6550	1210.17-05
SPEED SENSOR - ABS, LEFT FRONT, B2	3450.0-01
SPEED SENSOR - ABS, LEFT FRONT, B2	3450.1-03
SPEED SENSOR - ABS, LEFT FRONT, B2	3450.1-08
SPEED SENSOR - ABS, LEFT FRONT, B2	3450.1-12
SPEED SENSOR - ABS, LEFT REAR, B4	3450.0-01
SPEED SENSOR - ABS, LEFT REAR, B4	3450.1-03
SPEED SENSOR - ABS, LEFT REAR, B4	3450.1-08
SPEED SENSOR - ABS, LEFT REAR, B4	3450.1-12
SPEED SENSOR - ABS, RIGHT FRONT, B1	3450.0-01
SPEED SENSOR - ABS, RIGHT FRONT, B1	3450.1-03
SPEED SENSOR - ABS, RIGHT FRONT, B1	3450.1-08
SPEED SENSOR - ABS, RIGHT FRONT, B1	3450.1-12
SPEED SENSOR - ABS, RIGHT REAR B3	3450.0-01
SPEED SENSOR - ABS, RIGHT REAR B3	3450.1-03
SPEED SENSOR - ABS, RIGHT REAR B3	3450.1-08

03/98

0100.0-04

1997



INDEX

Z3

SPEED SENSOR – ABS, RIGHT REAR B3	3450.1-12
SPLICE LOCATION VIEWS	8000.0
START	1240.0
STARTER IMMOBILIZATION SWITCH, S235	1240.0-00
STARTER, M6510	1240.0-01
SUPPLEMENTAL RESTRAINT SYSTEM (AIR BAG)	3234.0
SUPPLEMENTAL RESTRAINT SYSTEM CONTROL MODULE, A12	3234.0
SYMBOLS	0140.0
TAIL LIGHT, LEFT, H25	6314.0-01
TAIL LIGHT, LEFT, H37	6314.0-01
TAIL LIGHT, RIGHT, H30	6314.0-01
TAIL LIGHT, RIGHT, H39	6314.0-01
TEMPERATURE SWITCH, S36	6450.6-03
TEMPERATURE WHEEL SWITCH, S531	6450.6-01
THROTTLE FLAP HEATER, E104	3450.1-02
THROTTLE POSITION SENSOR, R6252	1210.17-05
THROTTLE POSITION SENSOR, R6252	1210.20-05
TRANSMISSION CONTROL MODULE (EGS), A8500	2460.2
TRANSMISSION POSITION INDICATOR LIGHT, E82	6300.0-02
TRANSMISSION VALVE UNIT, Y8505y	2460.2-05
TRANSMISSION VALVE UNIT, Y8521	2460.2-01
TRANSMITTER MODULE (EWS II), A835	6135.0-00
TRUNK COMPARTMENT LIGHT, E32	6320.0-00
TRUNK LOCK MOTOR, M17	5126.0-03
TURN LIGHT, LEFT FRONT, H7	6313.0-02
TURN LIGHT, LEFT REAR, H6	6313.0-03
TURN LIGHT, RIGHT FRONT, H4	6313.0-02
TURN LIGHT, RIGHT REAR H5	6313.0-03
TURN/HAZARD LIGHTS	6313.0
UNLOADER RELAY, TERMINAL 15, K6326	1210.17-02
UNLOADER RELAY, TERMINAL 15, K6326	1210.20-02
UNLOADER RELAY, TERMINAL 15, K9	5203.0-00
VARIABLE CAMSHAFT CONTROL VALVE 1, Y6275	1210.17-01
VEHICLE SPEED SENSOR, B10	6211.0-04

WASHER JET HEATER, LEFT, E51	6169.0-00
WASHER JET HEATER, RIGHT, E52	6169.0-00
WASHER PUMP, M4	6160.1-01
WASHER PUMP, M4	6160.1-02
WATER VALVE, Y4z	6450.6-01
WINDOW MOTOR, DRIVER'S, M21	5133.0-02
WINDOW MOTOR, PASSENGER'S, M23	5133.0-02
WINDSHIELD WASHER JET HEATERS	6169.0-00
WIPER MOTOR, M3	6160.1-00
WIPER MOTOR, M3	6160.1-02
WIPER/WASHER MODULE (LOW II), A64	6160.1-02
WIPER/WASHER MODULE (WWM)	6160.1
WIPER/WASHER MODULE, A51	6160.1
WIPER/WASHER MODULE, A51	6167.1-00
WIPER/WASHER SWITCH, S5	6160.1-01
WIPER/WASHER SWITCH, S5	6160.1-02
ZKE CENTRAL LOCKING (ZV)	5126.0
ZKE POWER WINDOWS (FH)	5133.0

Schematics

The schematics divide the entire vehicle electrical system into individual circuits. Interacting electrical components are shown on one common schematic.

Switches and other components are represented in such a way that their general layout and function are self-explicit. They are arranged on the sheet such that the current path can be followed from positive (top) to negative (bottom).

Important: The components and wires are not drawn to scale. For instance, a lead with a length of over 1m can be shown as a lead that is only a few cm long. To ensure clear arrangement, all connectors, lines branches and connected components from the fuses to the component and from the component to ground connection are not shown within the individual cells. If required, reference can be made to cells **0670.3 Fuse Details** and **0670.4 Ground Distribution** where all lines are illustrated with all plug connections, line branches and connected components.

All circuit symbols used are listed and explained in cell **0140.0 Symbols**.

In cell **7000.0 Component Location Chart** all important connectors, ground points and components are listed in tabular form. It provides a precise description of the component locations in the vehicle.

In cell **7100.0 Component Location Views** the location of connectors and components which are difficult to locate are shown in line arts or illustrations. In cell **8000.0 Splice Location Views** all splices are listed in numerical order and illustrations are provided to assist in locating splices on larger harnesses. In cell **8500.0 Connector Views** diagrams of connectors with more than 2 pins are illustrated.

Example

General conventions can be explained based on the following schematic example.

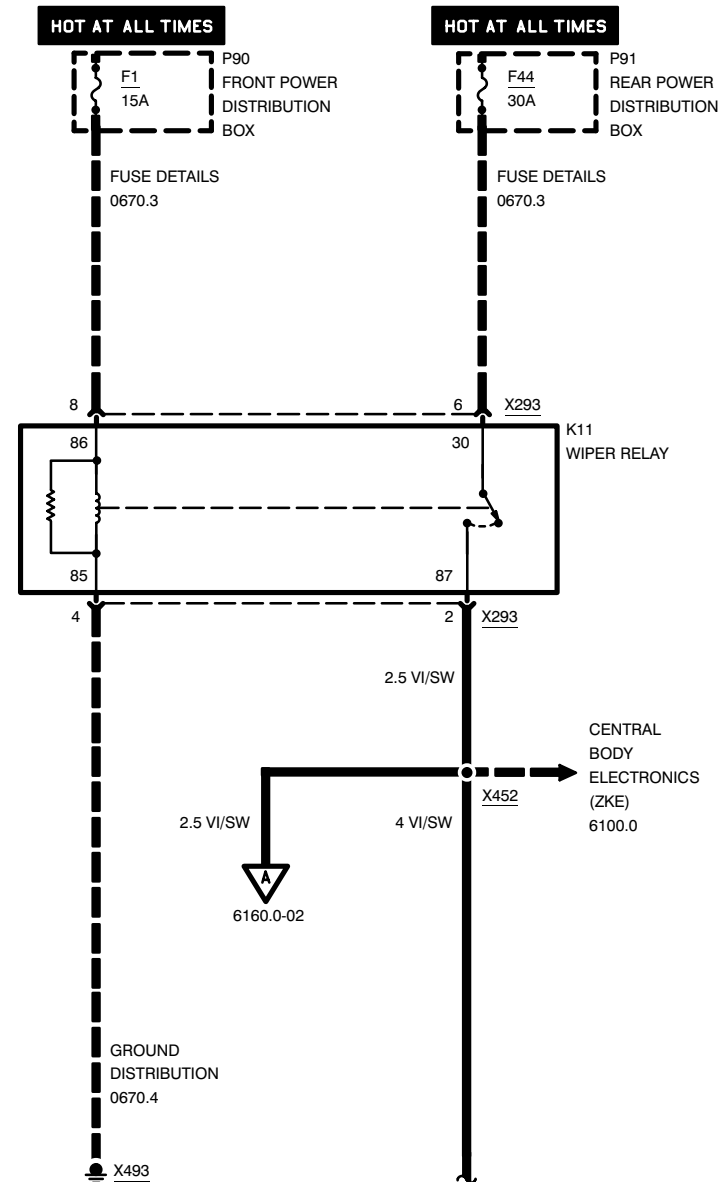



Z3

INTRODUCTION

General Conventions

1. Switches and relays are always shown in rest position (e.g. K11).
2. A component shown in a dashed frame signifies that the component is illustrated only in part (e.g. P90 and P91).
3. A component shown in a completely drawn frame signifies that the component is illustrated in full (e.g. K11).
4. The dashed line between pin 8 and pin 6 of connector X293 indicates that both pins belong to connector X293.
5. The dashed line from fuse F1 to pin 8 of connector X293 shows the positive supply of relay K11. If required, refer to cell **0670.3 Fuse Details** at fuse F1 for the complete line progressing with plug connections, line branches, wire colors and cross sections.
6. The dashed line with an arrow at splice X452 indicates that several wires lead to splice X452. All lines leading to the connection are illustrated in cell **6100.0 Central Body Electronics (ZKE)**. An interrupted line with an arrow indicates that only this one wire leads to another circuit.
7. The dashed line from pin 4 of connector X293 to ground X493 shows the ground supply for relay K11. If required, refer to cell **0670.4 Ground Distribution** at ground X493 for the complete line progression with all plug connections, line branches, wire colors, and cross sections.
8. The interrupted line from splice X452 with an **A** in the open arrow is continued on page 6160.0–02. Termination of wire 4 VI/SW from splice X452 with a wavy line indicates that the wire is continued on the opposite page.



BATTERY

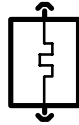

HEATING ELEMENT



VARIABLE RESISTANCE SENSOR
VARIABLE CONTACT IS MOVED BY AN EXTERNAL FORCE



ANTENNA



FUSE DETAILS



LOUDSPEAKER OR HORN



VARIABLE RESISTOR
RESISTANCE IS CHANGED BY TEMPERATURE OR PRESSURE



CONTROL/POWER ELECTRONICS



FUSIBLE LINK



LIGHT



DIODE CURRENT CAN FLOW ONLY IN DIRECTION OF ARROW



HALL EFFECT SENSOR



RADIO



CIRCUIT BREAKER



PERMANENT MAGNET MOTOR ONE SPEED



ZENER DIODE TO REGULATE VOLTAGE



TRANSISTORIZED SWITCH



THERMO SWITCH



PERMANENT MAGNET MOTOR TWO SPEEDS



LIGHT EMITTING DIODE

31



INDUCTIVE SENSOR



SOLENOID



KNOCK SENSOR



OXYGEN SENSOR



VEHICLE SPEED SENSOR

SYMBOLS

Z3

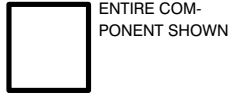

ENTIRE COMPONENT SHOWN



PART OF COMPONENT SHOWN

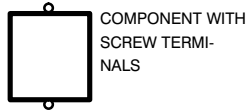

COMPONENT WITH SCREW TERMINALS

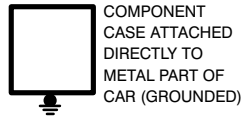

COMPONENT CASE ATTACHED DIRECTLY TO METAL PART OF CAR (GROUNDED)

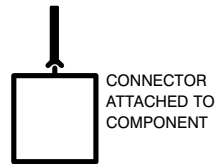

CONNECTOR ATTACHED TO COMPONENT

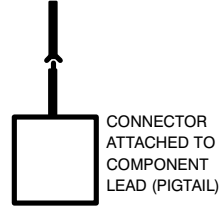

CONNECTOR ATTACHED TO COMPONENT LEAD (PIGTAIL)

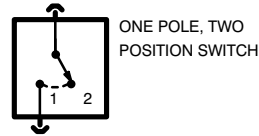

ONE POLE, TWO POSITION SWITCH

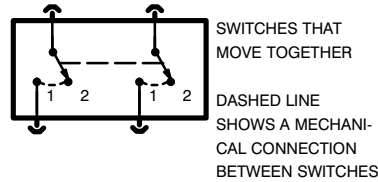

SWITCHES THAT MOVE TOGETHER

DASHED LINE SHOWS A MECHANICAL CONNECTION BETWEEN SWITCHES

WIRE COLOR	
BL	BLUE
BR	BROWN
GE	YELLOW
GN	GREEN
GR	GRAY
OR	ORANGE
RS	PINK
RT	RED
SW	BLACK
VI	VIOLET
WS	WHITE
TR	TRANSPARENT

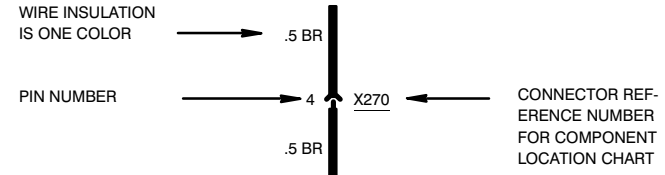

WIRE INSULATION IS ONE COLOR

PIN NUMBER

CONNECTOR REFERENCE NUMBER FOR COMPONENT LOCATION CHART

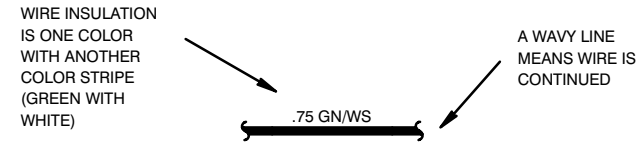

WIRE INSULATION IS ONE COLOR WITH ANOTHER COLOR STRIPE (GREEN WITH WHITE)

A WAVY LINE MEANS WIRE IS CONTINUED

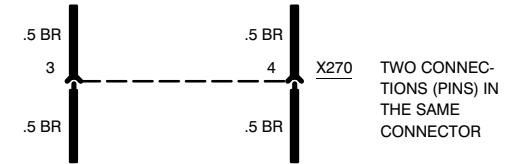

TWO CONNECTIONS (PINS) IN THE SAME CONNECTOR

DASHED LINE INDICATES TERMINALS OF THE SAME CONNECTOR

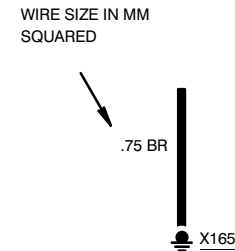

WIRE SIZE IN MM SQUARED

WIRE ATTACHED TO METAL PART OF CAR (GROUNDED)

GROUND NUMBERED FOR REFERENCE ON COMPONENT LOCATION CHART

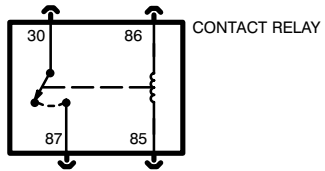

CONTACT RELAY

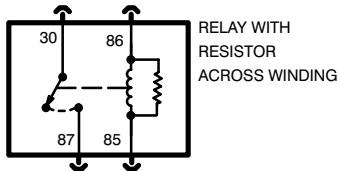

RELAY WITH RESISTOR ACROSS WINDING

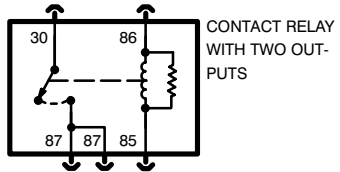

CONTACT RELAY WITH TWO OUTPUTS

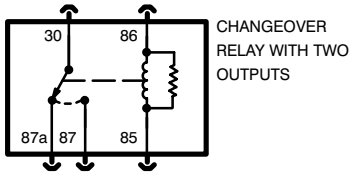

CHANGEOVER RELAY WITH TWO OUTPUTS

TERMINAL NUMBER	DESCRIPTION
30	RELAY INPUT
85	RELAY OUTPUT (WINDING)
86	RELAY INPUT (WINDING)
87	RELAY OUTPUT (ENERGIZED)
87a	RELAY OUTPUT (AT REST)

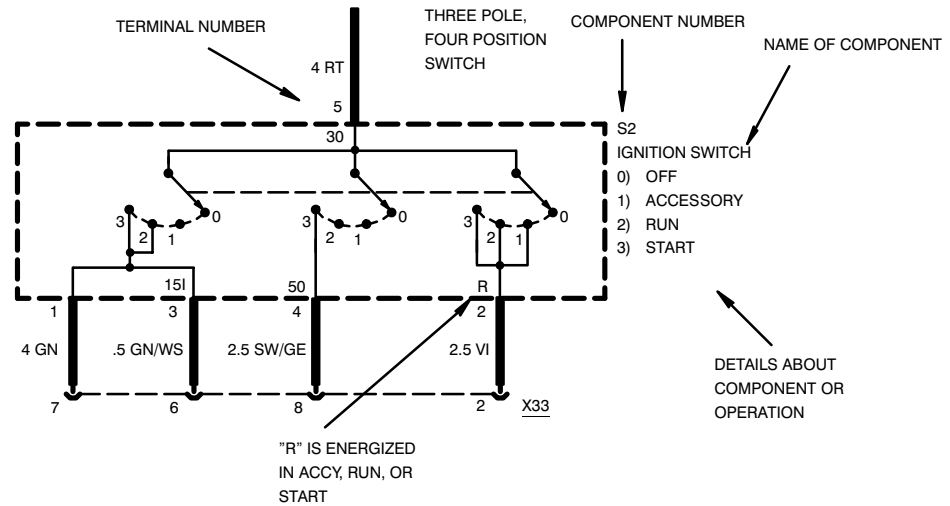

TERMINAL NUMBER	DESCRIPTION	TERMINAL NUMBER	DESCRIPTION
50	VOLTAGE: IGNITION SWITCH IN START	15I	VOLTAGE: IGNITION SWITCH IN RUN
30	VOLTAGE: SUPPLIED AT ALL TIMES	R	VOLTAGE: IGNITION SWITCH IN ACCESSORY, RUN OR START
15	VOLTAGE: IGNITION SWITCH IN RUN OR START	31	GROUND

HOT AT ALL TIMES

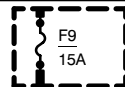

INDICATES THAT FUSE 9 IS SUPPLIED WITH POWER AT ALL TIMES

POWER STATUS

HOT AT ALL TIMES

HOT IN RUN AND START

HOT IN ACCY, RUN AND START

DESCRIPTION

VOLTAGE: SUPPLIED AT ALL TIMES

VOLTAGE: IGNITION SWITCH IN RUN OR START

VOLTAGE: IGNITION SWITCH IN ACCESSORY, RUN OR START



SYMBOLS

Z3

HOT IN ACCY, RUN AND START

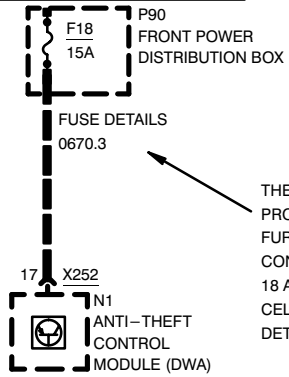

THE COMPLETE WIRE
PROGRESSION AND
FURTHER CIRCUITS
CONNECTED TO FUSE
18 ARE SHOWN IN
CELL "0670.3 FUSE
DETAILS" AT FUSE 18

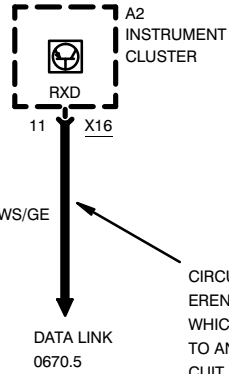

CIRCUIT REF-
ERENCE - A WIRE
WHICH CONNECTS
TO ANOTHER CIR-
CUIT

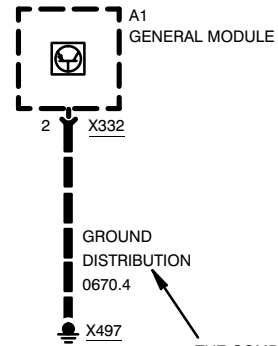

THE COMPLETE
WIRE PROGRES-
SION AND FUR-
THER CIRCUITS
CONNECTED TO
GROUND X497
ARE SHOWN IN
CELL "0670.4
GROUND
DISTRIBUTION" AT
GROUND X497

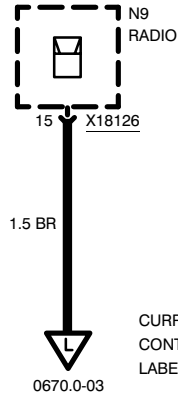

CURRENT PATH IS
CONTINUED AS
LABELED

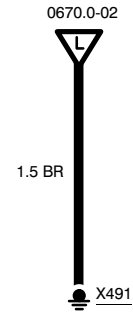

ARROW SHOWS
DIRECTION OF
CURRENT FLOW
AND IS REPEATED
WHERE CURRENT
PATH CONTINUES



Z3

POWER DISTRIBUTION CHART

FRONT POWER DISTRIBUTION BOX

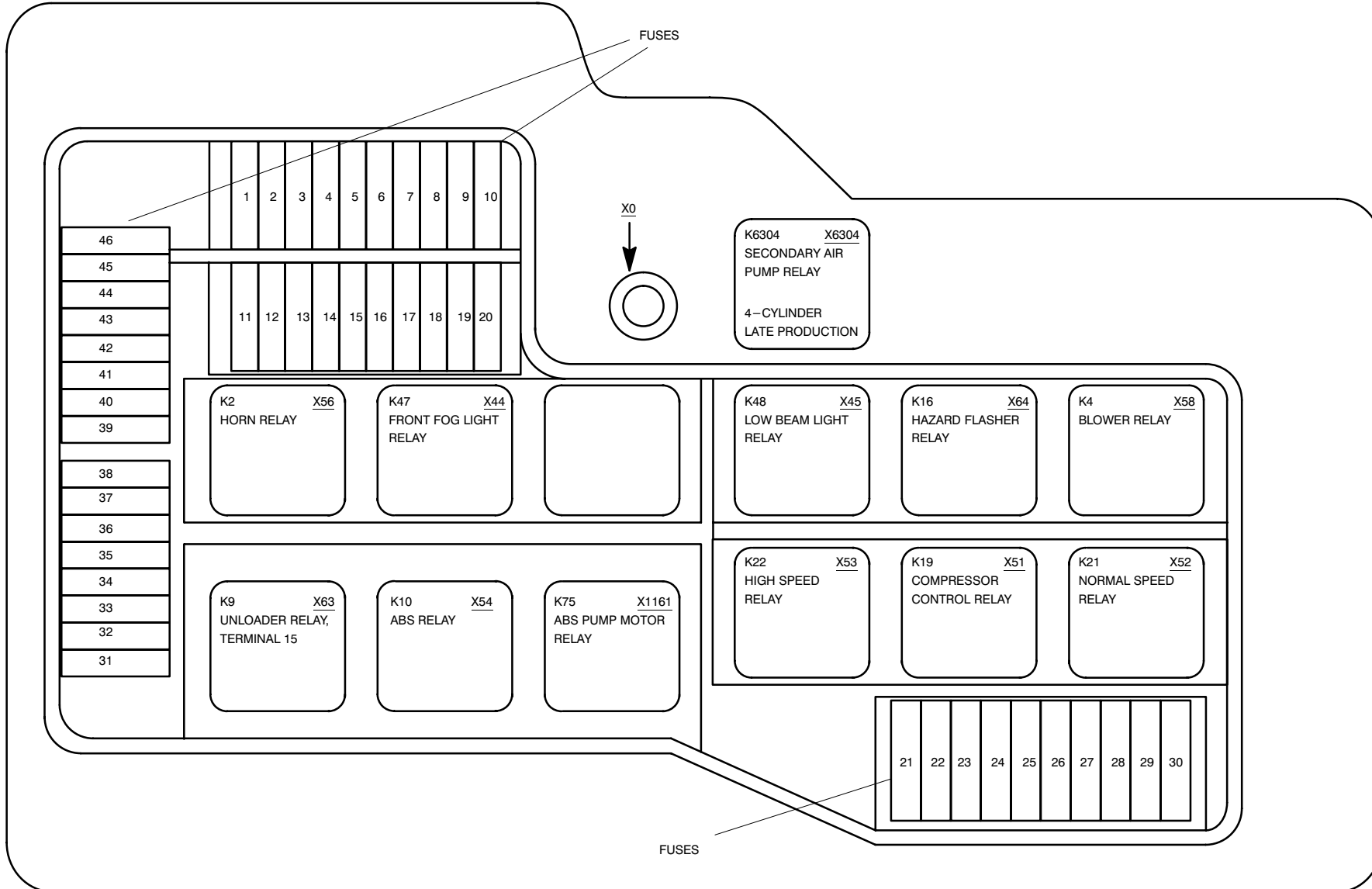



POWER DISTRIBUTION CHART

IN E-BOX

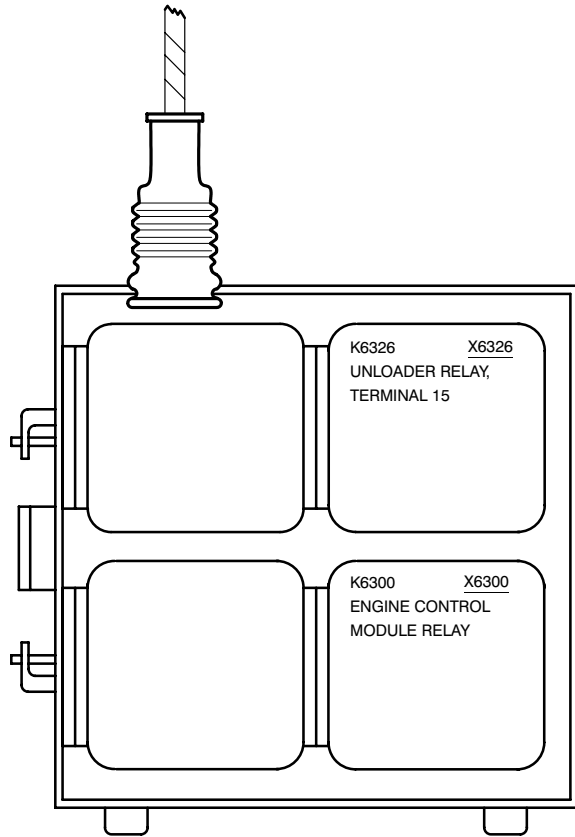

4-CYLINDER

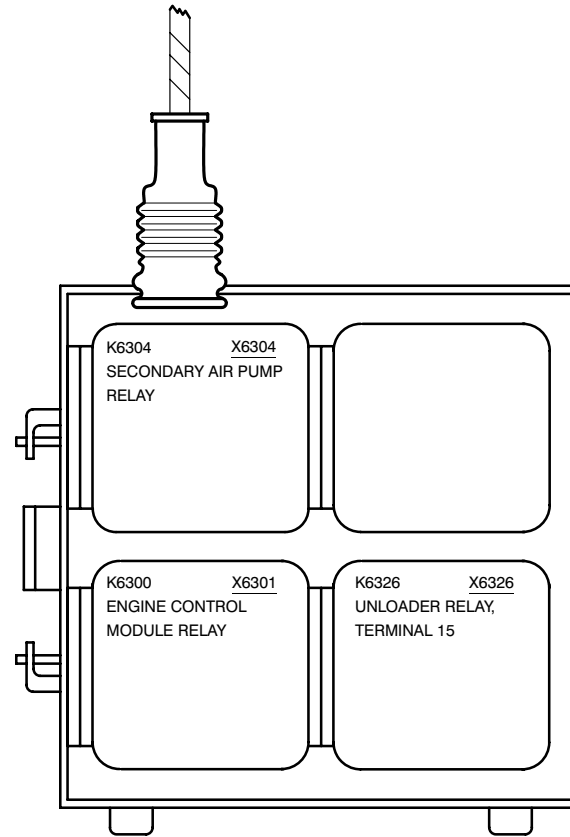

6-CYLINDER



Z3

POWER DISTRIBUTION CHART

RELAY PANEL UNDER LH SIDE OF DASHBOARD

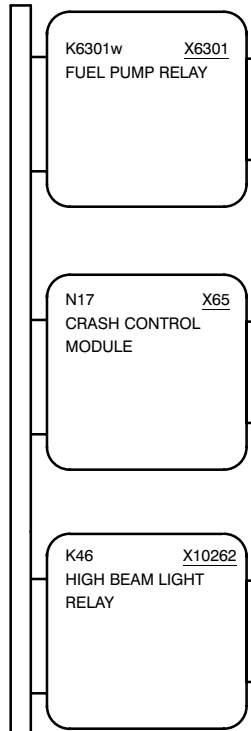

03/98

0670.0-02

1997



FUSE CHART

FUSES 1 TO 29

Z3

	FUSE NUMBER																												
	1	2	3	4	5	6	7	8	9	10	11	12	13	14	15	16	17	18	19	20	21	22	23	24	25	26	27	28	29
	30A	15A	30A	15A	30A	20A	5A	15A	20A	30A	7.5A	7.5A	5A	30A	15A	5A		15A	30A	30A	5A	5A	5A	10A	5A	10A	5A	5A	7.5A
1210.17 ENGINE CONTROL SYSTEM MS41.1 (6-CYLINDER M52)													●			●		●											
1210.20 ENGINE CONTROL SYSTEM (DME M5.2, 4-CYLINDER M44)													●			●		●											
1230.0 CHARGING SYSTEM																										●			
1240.0 START																												●	
1290.0 E-BOX FAN																													
2460.2 ELECTRONIC TRANSMISSION CONTROL (EGS A4S 310R)																										●		●	
3234.0 SUPPLEMENTAL RESTRAINT SYSTEM (AIR BAG)																											●		
3450.0 SLIP CONTROL (ABS)										●											●						●		
3450.1 SLIP CONTROL (ABS/ASC)										●											●						●	●	
5116.0 POWER MIRRORS																									●				
5126.0 ZKE CENTRAL LOCKING (ZV)							●																						
5133.0 ZKE POWER WINDOWS (FH)														●															
5200.0 POWER SEATS					●															●									
5203.0 HEATED SEATS			●																			●							
5430.0 ELECTRO-MECHANICAL CONVERTIBLE TOP	●																												
6100.0 CENTRAL BODY ELECTRONICS (ZKE IV)														●															
6133.0 HORN								●																					
6135.0 DRIVE-AWAY PROTECTION (EWS II)																												●	
6160.1 WIPER/WASHER MODULE (WWM)			●																										
6167.1 HEADLIGHT WASHER (SRA)			●																										
6169.0 WINDSHIELD WASHER JET HEATERS																								●					



FUSE CHART

FUSES 1 TO 29

Z3

		FUSE NUMBER																												
		1	2	3	4	5	6	7	8	9	10	11	12	13	14	15	16	17	18	19	20	21	22	23	24	25	26	27	28	29
		30A	15A	30A	15A	30A	20A	5A	15A	20A	30A	7.5A	7.5A	5A	30A	15A	5A		15A	30A	30A	5A	5A	5A	10A	5A	10A	5A	5A	7.5A
6211.0	INSTRUMENT CLUSTER																							●				●		
6213.3	DIGITAL CLOCK																													
6300.0	LIGHT SWITCH DETAILS																						●	●		●				
6312.0	HEADLIGHTS/FOG LIGHTS										●	●			●								●	●		●			●	
6313.0	TURN/HAZARD LIGHTS																							●						
6314.0	PARK/TAIL/UNDERHOOD LIGHTS																													
6320.0	LICENSE PLATE/LUGGAGE COMPARTMENT LIGHTS																													
6322.0	BACK UP LIGHTS																											●		
6325.0	BRAKE LIGHTS																													
6330.3	INTERIOR LIGHTS																													
6332.0	INTERIOR ACCESSORIES																													
6350.0	CRASH CONTROL MODULE										●	●														●				
6424.0	REAR WINDOW DEFOGGER					●																								
6450.6	INTEGRATED HEATING- AND CLIMATE CONTROL															●					●									
6510.1	RADIO/HIFI								●																					
6561.0	CELLULAR TELEPHONE (PROVISIONS)																													
6571.0	CRUISE CONTROL (TEMPOMAT)																													
6575.2	ANTI-THEFT SYSTEM (ALPINE)																												●	
6581.3	BOARD COMPUTER (BC-LOW)																													

