

1992

**BMW
850i
(E31)**

**Electrical
Troubleshooting
Manual**

Vehicles Produced 7/91 to 8/92



ELECTRICAL TROUBLESHOOTING MANUAL

8 SERIES – E31 (850i)

SCHEMATICS

MODEL YEAR 1992

0100.0	INDEX	3450.1	SLIP CONTROL (ABS/ASC)
0110.0	INTRODUCTION	3450.2	SLIP CONTROL (ABS/ASC+T)
0140.0	SYMBOLS	3715.1z	ELECTRONIC SHOCK ABSORBER CONTROLIII+ (EDC III+)
0670.0	POWER DISTRIBUTION CHART	5116.0	POWER MIRRORS
0670.1	FUSE CHART	5120.0	ZKE DOOR LOCK HEATING (TSH)
0670.2	POWER DISTRIBUTION	5126.0	ZKE CENTRAL LOCKING (ZV)
0670.3	FUSE DETAILS	5133.0	ZKE POWER WINDOWS (FH)
0670.4	GROUND DISTRIBUTION	5146.0	POWER SUN SHADES
0670.5	DATA LINK	5200.0	POWER SEATS
1210.6	ENGINE CONTROL SYSTEM (DMEM1.7, 12-CYLINDER M70)	5200.1	SEAT/MIRROR MEMORY SYSTEM (SM/SPM)
1230.0	CHARGING SYSTEM	5203.0	HEATED SEATS
1240.0	START	5212.0	LUMBAR SUPPORT
1270.1	ELECTRONIC THROTTLE CONTROL (EML12-CYLINDER)	5410.0	ZKE SUNROOF (SHD)
1290.0	E-BOX FAN	6100.0z	CENTRAL BODY ELECTRONICS (ZKE II)
2460.0z	ELECTRONIC TRANSMISSION CONTROL(EGS)	6133.0	HORN
3231.0	ELECTRIC STEERING COLUMN ADJUSTMENT	6160.0z	ZKE WIPER/WASHER CONTROL
3231.1	STEERING COLUMN MEMORY (LSM)	6164.0	ZKE WINDSHIELD WIPER PRESSURE CONTROL (ADV)
3234.0	SUPPLEMENTAL RESTRAINT SYSTEM (AIRBAG)	6167.0	ZKE HEADLIGHT WASHER (SRA)
3240.0	POWER ASSIST STEERING (SERVOTRONIC)	6169.0	WINDSHIELD WASHER JET HEATERS
		6210.0	BODY ELECTRONICS MODULE (EKM)
		6211.0	INSTRUMENT CLUSTER

SCHEMATICS

6300.0	LIGHT SWITCH DETAILS	6424.0z	REAR WINDOW DEFOGGER/ANTENNA
6301.0	LAMP MONITOR (LKM)	6450.0	AUTOMATIC HEATING/AC CONTROL (IHKA)
6312.0	HEADLIGHTS/FOG LIGHTS	6454.0	AUXILIARY FAN
6313.0	TURN/HAZARD LIGHTS	6510.1	RADIO/HIFI
6314.0	PARK/TAIL/UNDERHOOD LIGHTS	6561.0	CELLULAR TELEPHONE (PROVISIONS)
6320.0	LICENSE PLATE/LUGGAGE COMPARTMENT LIGHTS	6575.1	ANTI-THEFT SYSTEM III (DWA III)
6322.0	BACK UP LIGHTS	6581.0z	MULTI-INFORMATION DISPLAY (MID)
6325.0	BRAKE LIGHTS	6610.0	INFRARED LOCKING (IRS)
6330.0z	ZKE INTERIOR LIGHTS (IB)	7000.0	COMPONENT LOCATION CHART
6332.0	INTERIOR ACCESSORIES	7100.0	COMPONENT LOCATION VIEWS
6350.0	CRASH CONTROL MODULE	8000.0	SPLICE LOCATION VIEWS
6412.2	PARK VENTILATION WITH IHKA	8500.0	CONNECTOR VIEWS

BMW
8

0100.0



INDEX

ABS HYDRAULIC UNIT, Y1	3450
ABS RELAY, K10	3450.1-00
ACCELERATION SENSOR, RIGHT FRONT, B41	3715.1-01
ACCELERATION SENSOR, RIGHT REAR, B48	3715.1-01
ACCESSORY TABLE MICROSWITCH, S119	3231.0-00
ACOUSTIC DEVICE, H10z	6210.0-08
AIR BAG GAS GENERATOR I, PASSENGER'S, G6	3234.0-02
AIR BAG GENERATOR, DRIVER'S, G5	3234.0-01
AIR CONDITIONING COMPRESSOR (IHKA), Y3	6450.0-13
AIR CONDITIONING PRESSURE SWITCH, S96	6450.0-12
AIR CONDITIONING RELAY, K33	6454.0-01
ANTENNA AMPLIFIER AM/FM, N8	6424.0-00
ANTI-THEFT CONTROL MODULE (DWA), N1	6575.1
ANTI-THEFT HORN (DWA), H1	6575.1-00
ANTI-THEFT SYSTEM III (DWA III)	6575.1
ASC SWITCH, S6	3450
AUTOMATIC AIR RECIRCULATION CONTROL MODULE, A417 ..	6450.0-15
AUTOMATIC AIR RECIRCULATION SENSOR, B414	6450.0-15
AUTOMATIC HEATING/AC CONTROL (IHKA)	6450.0
AUTOMATIC HEATING/AC CONTROL MODULE (IHKA), A11 ..	6450.0-00
AUTOMATIC HEATING AND AIR CONDITIONING SWITCH (IHKA), S26	6450.0-01
AUXILIARY FAN	6454.0
AUXILIARY FAN MOTOR, M9	6454.0-00
AUXILIARY FUSE BOX, P95	0670.2-00
AUXILIARY TURN LIGHT, RIGHT FRONT, H8	6313.0-02
AUXILIARY WATER PUMP RELAY, K8	6450.0-11
BACK UP LIGHT, LEFT, H27	6322.0-00
BACK UP LIGHT, RIGHT, H28	6322.0-00
BACK UP LIGHTS	6322.0
BACK-UP SWITCH, S302	6322.0-00
BATTERY I, RIGHT, G1z	0670.2-00
BATTERY II, LEFT, G4	0670.2-06
BLOWER MOTOR, M30	6450.0-01
BLOWER RELAY, K4	6450.0-00
BODY ELECTRONICS MODULE, A25	6210.0
BODY ELECTRONICS MODULE (EKM)	6210.0

BRAKE FLUID LEVEL SWITCH, B18	6210.0-06
BRAKE LIGHT, LEFT, H24	6325.0-00
BRAKE LIGHT SWITCH, S29	6325.0-00
BRAKE LIGHTS	6325.0
BRAKE PAD SENSOR, LEFT FRONT, B16	6210.0-05
BRAKE PAD SENSOR, RIGHT REAR, B17	6210.0-05
BRAKE PRESSURE REGULATING SWITCH, B19	6210.0-06
BRAKE PRESSURE SWITCH, B20	6210.0-06
CASSETTE BOX LIGHT, E45y	6300.0-04
CD CHANGER, N22	6510.1
CELLULAR TELEPHONE (PROVISIONS)	6561.0
CENTRAL BODY ELECTRONICS (ZKE)	6100.0
CENTRAL LOCKING TRUNK LID MOTOR RELAY (ZV), K70 ..	5126.0-02
CHARGING SYSTEM	1230.0
CLUTCH SWITCH, S32	1270.1-09
COMBINATION SWITCH, S7	6301.0-00
COMPACT INFRARED LOCKING, N13z	6610.0
COMPONENT LOCATION CHART	7000.0
COMPONENT LOCATION VIEWS	7100.0
COMPRESSOR CONTROL RELAY, K19	6450.0-12
COMPRESSOR CUT-OFF RELAY, K60	6450.0-12
CONCEALING HEADLIGHT MOTOR, LH, M18	6312.0-06
CONCEALING HEADLIGHT MOTOR, RH, M19	6312.0-06
CONCEALING HEADLIGHTS RELAY, K39	6312.0-06
CONNECTOR VIEWS	8500.0
CONSUMER CUT-OFF RELAY I, K72	6330.0-02
CONSUMER CUT-OFF RELAY II, K73	6330.0-02
CONTACT RING, C100	3234.0-01
CRASH CONTROL MODULE	6350.0
CRASH CONTROL MODULE, N17	6350.0-01
CRUISE CONTROL SWITCH (EML), S11	1270.1-02
CYL. 1 FUEL INJECTION VALVE, Y201	1210.6-02
CYL. 1-6 AIR TEMPERATURE SENSOR, B224	1210.6-08
CYL. 1-6 CRANKSHAFT POSITION/RPM SENSOR, B222 ..	1210.6-05
CYL. 1-6 CYLINDER IDENTIFICATION SENSOR, B220 ..	1210.6-05
CYL. 1-6 ENGINE CONTROL MODULE (DME), A211	1210.6
CYL. 1-6 ENGINE CONTROL MODULE RELAY, K212	1210.6-01



INDEX

CYL. 1-6 EVAPORATIVE EMISSION VALVE, Y221	1210.6-03
CYL. 1-6 FUEL PUMP RELAY, K210	1210.6-04
CYL. 1-6 HEATED OXYGEN SENSOR, B301	1210.6-05
CYL. 1-6 IGNITION COIL, T201A	1210.6-00
CYL. 1-6 MASS AIR FLOW SENSOR, B226	1210.6-03
CYL. 1-6 THROTTLE BODY (EML), M202	1270.1-05
CYL. 2 FUEL INJECTION VALVE, Y202	1210.6-02
CYL. 3 FUEL INJECTION VALVE, Y203	1210.6-02
CYL. 4 FUEL INJECTION VALVE, Y204	1210.6-02
CYL. 5 FUEL INJECTION VALVE, Y205	1210.6-02
CYL. 6 FUEL INJECTION VALVE, Y206	1210.6-02
CYL. 7-12 AIR TEMPERATURE SENSOR, B225	1210.6-16
CYL. 7-12 CRANKSHAFT POSITION/RPM SENSOR, B223	1210.6-15
CYL. 7-12 CYLINDER IDENTIFICATION SENSOR, B221	1210.6-15
CYL. 7-12 ENGINE CONTROL MODULE (DME), A212	1210.6
CYL. 7-12 ENGINE CONTROL MODULE RELAY, K213	1210.6-11
CYL. 7-12 EVAPORATIVE EMISSION VALVE, Y222	1210.6-13
CYL. 7-12 FUEL PUMP, M11	1210.6-14
CYL. 7-12 FUEL PUMP RELAY, K211	1210.6-14
CYL. 7-12 HEATED OXYGEN SENSOR, B302	1210.6-15
CYL. 7-12 IGNITION COIL, T202A	1210.6-10
CYL. 7-12 MASS AIR FLOW SENSOR, B227	1210.6-13
CYL. 7-12 THROTTLE BODY (EML), M203	1270.1-06
CYL. 7 FUEL INJECTION VALVE, Y207	1210.6-12
CYL. 8 FUEL INJECTION VALVE, Y208	1210.6-12
CYL. 9 FUEL INJECTION VALVE, Y209	1210.6-12
CYL. 10 FUEL INJECTION VALVE, Y210	1210.6-12
CYL. 11 FUEL INJECTION VALVE, Y211	1210.6-12
CYL. 12 FUEL INJECTION VALVE, Y212	1210.6-12
DASH LIGHT, E41	6450.0-07
DASH VENT MIXING FLAP MOTOR, M34	6450.0-08
DATA LINK	0670.5
DATA LINK CONNECTOR, D100	0670.5
DAYTIME RUNNING LIGHTS CODING DIODE, V4	6314.0-02
DEFROSTER FLAP MOTOR, M35	6450.0-10
DIMMER, N3	6300.0-02
DOOR HANDLE SWITCH, DRIVER'S, S48	5120.0-00

DOOR HANDLE SWITCH, PASSENGER'S, S79	6100.0-03
DOOR JAMB SWITCH, DRIVER'S, S14	6575.1-01
DOOR JAMB SWITCH, PASSENGER'S, S13	6575.1-01
DOOR LOCK HEATER, E48	5120.0-00
DOOR LOCK MOTOR, DRIVER'S, M12	5126.0-03
DOOR LOCK MOTOR, PASSENGER'S, M13	5126.0-03
DOOR LOCK SWITCH, DRIVER'S, S47	5126.0-00
DOOR LOCK SWITCH, PASSENGER'S, S49	5126.0-00
DOOR MODULE, DRIVER'S, A23	6100.0
DOOR MODULE, PASSENGER'S, A24	6100.0
DOOR PANEL LIGHT, DRIVER'S, E78	6300.0-04
DOOR PANEL LIGHT, PASSENGER'S, E79	6300.0-04
E-BOX FAN	1290.0
E-BOX FAN, M201	1290.0-00
EDC MOTOR, LEFT FRONT, Y401	3715.1-02
EDC MOTOR, LEFT REAR, Y403	3715.1-02
EDC MOTOR, RIGHT FRONT, Y402	3715.1-02
EDC MOTOR, RIGHT REAR, Y404	3715.1-02
EDC RELAY, K67	3715.1-00
EDC SWITCH, S105	3715.1-00
ELECTRIC POWER PROTECTION RELAY, K15	5126.0-02
ELECTRIC POWER PROTECTION RELAY II, K30	5126.0-02
ELECTRIC STEERING COLUMN ADJUSTMENT	3231.0
ELECTRO-HYDRAULIC CONVERTER (SERVOTRONIC), B15	3240.0-00
ELECTROCHROMIC REAR VIEW MIRROR, A22z	5116.0-02
ELECTRONIC SHOCK ABSORBER CONTROL III+ (EDC III+)	3715.1
ELECTRONIC SHOCK ABSORBER CONTROL MODULE (EDC), A413	3715.1-00
ELECTRONIC THROTTLE CONTROL (EML 12-CYLINDER)	1270.1
ELECTRONIC TRANSMISSION CONTROL (EGS)	2460.0
ENGINE CONTROL SYSTEM (DME M1.7, 12-CYLINDER M70)	1210.6
ENGINE COOLANT TEMPERATURE SENSOR, B207	6210.0-07
ENGINE COOLANT TEMPERATURE SENSOR (EML), B209	1270.1-03
EVAPORATOR TEMPERATURE SENSOR, B14	6450.0-03
FINAL STAGE UNIT, N2	6450.0-01
FLASHER LIGHT RELAY, K52z	6312.0-05
FOG LIGHT, LEFT, E26	6312.0-03



INDEX

FOG LIGHT, RIGHT, E27	6312.0-03	HIGH BEAM FLASHER LIGHT, RIGHT, E70z	6312.0-05
FOG LIGHT SWITCH, S10	6312.0-02	HIGH BEAM LIGHT, LEFT, E11	6312.0-05
FOOTWELL FLAP MOTOR, LEFT, M31	6450.0-09	HIGH BEAM LIGHT, RIGHT, E12	6312.0-05
FOOTWELL FLAP MOTOR, RIGHT, M32	6450.0-08	HIGH BEAM LIGHT RELAY, K46	6312.0-05
FOOTWELL LIGHT, LEFT FRONT, E61	6330.0-03	HIGH LEVEL STOP LIGHT, H34	6325.0-00
FOOTWELL LIGHT, RIGHT FRONT, E62	6330.0-03	HIGH RANGE SPEAKER, LEFT FRONT, H59	6510.1-01
FRESH AIR FLAP MOTOR, M36	6450.0-10	HIGH RANGE SPEAKER, LEFT REAR, H56	6510.1
FRONT CIGAR LIGHTER, E28	6332.0-03	HIGH RANGE SPEAKER, RIGHT FRONT, H50	6510.1-02
FRONT CIGAR LIGHTER LIGHT, E29	6332.0-03	HIGH RANGE SPEAKER, RIGHT REAR, H53	6510.1
FRONT CONSOLE WINDOW SWITCH ASSEMBLY, S40	5133.0-00	HIGH SPEED RELAY, K22	6454.0-00
FRONT DOME LIGHT/MAP READING ASSEMBLY, E34	6330.0-03	HORN	6133.0
FRONT POWER DISTRIBUTION BOX, P90	0670.2	HORN, LEFT, H2	6133.0-00
FUEL LEVEL SENSOR I, B6z	6210.0-08	HORN, RIGHT, H3	6133.0-00
FUEL LEVEL SENSOR II, B25	6210.0-08	HORN RELAY, K2	6133.0-00
FUEL PUMP, M2	1210.6-04	HORN SWITCH, S4	6133.0-00
FUSE CHART	0670.1	IGNITION SWITCH, S2	0670.2-02
FUSE DETAILS	0670.3	IMPACT SENSOR, LEFT FRONT, S71	3234.0-01
FUSIBLE LINK, F0	0670.2-06	IMPACT SENSOR, RIGHT FRONT, S72	3234.0-01
FUSIBLE LINK (50A), F99	0670.2-00	INDEX	0100.0
GAS FILLER LOCK MOTOR, M16	5126.0-03	INERTIA SWITCH, S27	6350.0-01
GENERAL MODULE, A1	6100.0	INFRARED LOCKING (IRS)	6610.0
GENERATOR, G2	1230.0-00	INFRARED RECEIVER, N14	6610.0-00
GLOVE BOX CENTRAL LOCKING SWITCH, S118	5126.0-01	INSIDE DOOR HANDLE SWITCH, DRIVER'S, S89	5120.0-00
GLOVE BOX LIGHT, E42	6332.0-00	INSIDE DOOR HANDLE SWITCH, PASSENGER'S, S90	6100.0-03
GLOVE BOX LIGHT SWITCH I, S37z	6332.0-01	INSTRUMENT CLUSTER	6211.0
GLOVE BOX LIGHT SWITCH II, S113	6332.0-01	INTENSIVE WASH PUMP, M5	6160.0-02
GROUND DISTRIBUTION	0670.4	INTENSIVE WASH RELAY, K42	6160.0-02
HAZARD FLASHER RELAY, K16	6313.0-00	INTERIOR ACCESSORIES	6332.0
HAZARD SWITCH, S18	6313.0-01	INTERIOR LIGHT, LEFT REAR, E39	6330.0-03
HEADLIGHT/FOGLIGHT CLEANING MODULE (SRA), N6	6167.0-02	INTERIOR LIGHT, RIGHT REAR, E40	6330.0-03
HEADLIGHT/FOGLIGHT WASHER PUMP, M7	6167.0-02	INTERIOR LIGHT RELAY, K29	6330.0-03
HEADLIGHTS/FOGLIGHTS	6312.0	INTRODUCTION	0110.0
HEAT EXCHANGER TEMPERATURE SENSOR, LH, B11	6450.0-03	IR/DWA LED, V5	6610.0-00
HEAT EXCHANGER TEMPERATURE SENSOR, RH, B12	6450.0-03	JUMPER PLUG, B900	1240.0-01
HEATED SEATS	5203.0	JUMPER PLUG FOR HORN/TELEPHONE, K51	6133.0-00
HIFI AMPLIFIER, A18	6510.1	LAMP CONTROL MODULE, A3	6301.0
HIGH BEAM FLASHER LIGHT, LEFT, E69	6312.0-05	LAMP MONITOR (LKM)	6301.0



INDEX

LICENSE PLATE LIGHT, LEFT, E43	6320.0-01
LICENSE PLATE LIGHT, RIGHT, E44	6320.0-01
LICENSE PLATE/LUGGAGE COMPARTMENT LIGHTS	6320.0
LIGHT ASSEMBLY I, LEFT REAR, E46z	0670.4-12
LIGHT ASSEMBLY I, RIGHT REAR, E47z	0670.4-12
LIGHT BAND, LEFT, E9046	0670.4-01
LIGHT BAND, RIGHT, E9047	0670.4-02
LIGHT SWITCH, S8	6300.0-00
LIGHT SWITCH DETAILS	6300.0
LOCK-SENSOR CONTROL MODULE, A26	6450.0-13
LONGITUDINAL ACCELERATION SENSOR, B49	3715.1-01
LOW BEAM LIGHT, LEFT, E13	6312.0-00
LOW BEAM LIGHT, RIGHT, E14	6312.0-00
LOW RANGE SPEAKER, LEFT FRONT, H58	6510.1-02
LOW RANGE SPEAKER, LEFT REAR, H57	6510.1
LOW RANGE SPEAKER, RIGHT FRONT, H51	6510.1-02
LOW RANGE SPEAKER, RIGHT REAR, H52	6510.1
LUMBAR SUPPORT	5212.0
MAKEUP MIRROR LIGHT, DRIVER'S, E35	6300.0-02
MAKEUP MIRROR LIGHT, PASSENGER'S, E36	6300.0-02
MAKEUP MIRROR SWITCH, DRIVER'S, S77	6300.0-02
MAKEUP MIRROR SWITCH, PASSENGER'S, S78	6300.0-02
MARKER LIGHT, LEFT FRONT, E21	6314.0-04
MARKER LIGHT, RIGHT FRONT, E22	6314.0-04
MEMORY MIRROR, DRIVER'S SIDE, Y9	5200.1-07
MEMORY MIRROR, PASSENGER'S SIDE, Y10	5200.1-08
MEMORY MIRRORS CONTROL SWITCH, S12	5200.1-06
MEMORY SEAT ADJUSTMENT SWITCH, DRIVER'S, S50	5200.1-00
MEMORY SEAT MIRRORS SWITCH, S57	5200.1-01
MID-HIGH RANGE SPEAKER, LEFT, H42	6510.1-01
MID-HIGH RANGE SPEAKER, RIGHT, H43	6510.1-02
MIDRANGE SPEAKER, LEFT FRONT, H55	6510.1-01
MIDRANGE SPEAKER, RIGHT FRONT, H54	6510.1-02
MIRROR, DRIVER'S SIDE, Y5	5116.0-01
MIRROR, PASSENGER'S SIDE, Y6	5116.0-01
MIRROR CONTROL SWITCH, S17	5116.0-00
MIXING ACTUATOR, R1	6450.0-04

MIXING FLAP MOTOR, LEFT, M39	6450.0-09
MULTI-INFORMATION DISPLAY (MID)	6581.0
MULTI-INFORMATION DISPLAY (MID), N4z	6581.0-00
NORMAL SPEED RELAY, K21	6454.0-00
OIL LEVEL SENSOR, B205	6210.0-07
OIL PRESSURE SWITCH, B206	6210.0-06
OUTSIDE TEMPERATURE SENSOR, B13	6450.0-03
PARK BRAKE SWITCH, S31	6210.0-04
PARK HEATING/VENTILATION RELAY BOX, A15	6412.2-02
PARK LIGHT, LEFT, E15	6314.0-01
PARK LIGHT, RIGHT, E19	6314.0-01
PARK LIGHT RELAY, LEFT, K26	6314.0-02
PARK LIGHT/LICENSE PLATE LIGHT RELAY, RIGHT, K25	6314.0-02
PARK/TAIL/UNDERHOOD LIGHTS	6314.0
PARK VENTILATION WITH IHKA	6412.2
PEDAL POSITION SENSOR, R10	1270.1-03
POWER ASSIST STEERING (SERVOTRONIC)	3240.0
POWER DISTRIBUTION	0670.2
POWER DISTRIBUTION CHART	0670.0
POWER MIRRORS	5116.0
POWER SEATS	5200.0
POWER SUN SHADES	5146.0
PRESSURE SENSOR/PLUNGER, Y16	3450.2-07
PRESSURE SWITCH, B9508	6450.0-12
PROGRAM SWITCH, S8517	2460.0-03
RADIO, N9	6510.1
RADIO/HIFI	6510.1
RADIO RECEIVER, N20	6510.1
REAR DEFOGGER/ANTENNA, E10	6424.0-01
REAR DEFOGGER I, E9	6424.0-01
REAR DEFOGGER RELAY, K13	6424.0-00
REAR POWER DISTRIBUTION BOX, P94	0670.2-07
REAR WINDOW DEFOGGER/ANTENNA	6424.0
REAR WINDOW DEFOGGER SWITCH, S76	6450.0-07
RECIRCULATION FLAP MOTOR, M40	6450.0-10
RELAY MODULE, A5	6100.0
SEAT BELT SWITCH, DRIVER'S, S58	6210.0-04



INDEX

SEAT CONTROL SWITCH, DRIVER'S SEAT, S51	5200.0-00
SEAT CONTROL SWITCH, PASSENGER'S SEAT, S56	5200.0-01
SEAT CUSHION MOVEMENT POTENTIOMETER, R9	5200.1-02
SEAT CUSHION REAR HEIGHT POTENTIOMETER, R8	5200.1-02
SEAT CUSHION TILT MOTOR, DRIVER'S, M50	5200.0-00
SEAT CUSHION TILT MOTOR, PASSENGER'S, M61	5200.0-01
SEAT HEATER, DRIVER'S, E57	5203.0-00
SEAT HEATER, PASSENGER'S, E58	5203.0-00
SEAT HEATER SWITCH, DRIVER'S SEAT, S53	5203.0-00
SEAT HEATER SWITCH, PASSENGER'S SEAT, S54	5203.0-00
SEAT HEIGHT MOTOR, DRIVER'S, M52	5200.0-00
SEAT HEIGHT MOTOR, PASSENGER'S, M59	5200.0-01
SEAT HEIGHT POTENTIOMETER, R6	5200.1-03
SEAT LUMBAR SUPPORT MOTOR/VALVE, DRIVER'S, M55z	5212.0-00
SEAT LUMBAR SUPPORT MOTOR/VALVE, PASSENGER'S, M56z	5212.0-00
SEAT LUMBAR SUPPORT SWITCH, PASSENGER'S, S55	5212.0-00
SEAT LUMBAR SWITCH, DRIVER'S, S52	5212.0-00
SEAT/MIRROR MEMORY CONTROL MODULE, A21	5200.1
SEAT/MIRROR MEMORY SYSTEM (SM/SPM)	5200.1
SEAT MOVEMENT MOTOR, DRIVER'S, M51	5200.0-00
SEAT MOVEMENT MOTOR, PASSENGER'S, M60	5200.0-01
SEAT REMOTE CONTROL MODULE, PASSENGER'S, A34	3231.0-00
SEATBACK HEATER, DRIVER'S, E56	5203.0-00
SEATBACK HEATER, PASSENGER'S, E59	5203.0-00
SEATBACK POTENTIOMETER, R7	5200.1-03
SEATBACK RECLINER MOTOR, DRIVER'S, M53	5200.0-00
SEATBACK RECLINER MOTOR, PASSENGER'S, M58	5200.0-01
SEATBACK SWITCH, LH DRIVER'S, S104	6210.0-04
SEATBACK SWITCH, LH PASSENGER'S, S122	6210.0-04
SEATBACK SWITCH, RH DRIVER'S, S103	6210.0-04
SEATBACK SWITCH, RH PASSENGER'S, S121	6210.0-04
SERVOTRONIC CONTROL MODULE, A17	3240.0-00
SIDE MARKER LIGHT, LEFT REAR, E9021	0670.4-12
SIDE MARKER LIGHT, RIGHT REAR, E9022	0670.4-12
SHIFT LOCK, S8522	2460.0-01
SLIP CONTROL (ABS/ASC)	3450.1
SLIP CONTROL (ABS/ASC + T)	3450.2

SLIP CONTROL MODULE (ABS/ASC), A70	3450.1
SLIP CONTROL MODULE (ABS/ASC + T), A9070	3450.2
SPEAKER, RIGHT REAR, H45	6510.0
SPEED SENSOR - ABS, LEFT FRONT, B2	3450
SPEED SENSOR - ABS, LEFT REAR, B4	3450
SPEED SENSOR - ABS, RIGHT FRONT, B1	3450
SPEED SENSOR - ABS, RIGHT REAR, B3	3450
SPLICE LOCATION VIEWS	8000.0
START	1240.0
STARTER, M1	1240.0-01
STARTER RELAY, K1	1240.0-01
STEERING ANGLE SENDER, B40	3715.1-01
STEERING COLUMN ADJUST POTENTIOMETER, R18	3231.1-00
STEERING COLUMN ANGLE ADJUST MOTOR, M83	3231.0-00
STEERING COLUMN ANGLE ADJUST POTENTIOMETER, R19z	3231.1-00
STEERING COLUMN LENGTH ADJUST MOTOR, M82	3231.0-00
STEERING COLUMN MEMORY (LSM)	3231.1
SUN BLIND CONTROL MODULE, A82	5146.0-00
SUN BLIND MOTOR, M74	5146.0-00
SUN BLIND SWITCH, S110	5146.0-00
SUNROOF MODULE, A33	5410.0-01
SUNROOF MOTOR, M24	5410.0-01
SUNROOF SWITCH, S38	5410.0-01
SUPPLEMENTAL RESTRAINT SYSTEM (AIR BAG)	3234.0
SUPPLEMENTAL RESTRAINT SYSTEM CONTROL MODULE, A12	3234.0
SUPPRESSION FILTER, C900	6424.0-01
SYMBOLS	0140.0
TAIL LIGHT, LEFT, H25	6314.0-04
TAIL LIGHT, RIGHT, H30	6314.0-04
TAIL LIGHT, UPPER LEFT, H9025	6314.0-01
TAIL LIGHT, UPPER RIGHT, H9030	6314.0-01
TELEPHONE TRANSCEIVER, H38	6561.0-00
TEMPERATURE SENSOR, B21z	6210.0-07
TEMPERATURE SWITCH, B210	1290.0-00
TEMPERATURE SWITCH, S36	6454.0-00
THIGH SUPPORT MOTOR, DRIVER'S, M65	5200.0-02



INDEX

THIGH SUPPORT POTENTIOMETER, R15	5200.1-04
THIGH SUPPORT SWITCH, DRIVER'S, S93	5200.0-02
THIGH SUPPORT SWITCH, PASSENGER'S, S94	5200.0-02
THROTTLE CONTROL MODULE (EML), A220	1270.1
TRANSMISSION CONTROL MODULE (EGS), A8500	2460.0
TRANSMISSION RANGE LEVER LIGHT, S8515	2460.0-05
TRANSMISSION RANGE SELECTOR LEVER LIGHT, S8518	2460.0-03
TRANSMISSION VALVE UNIT, Y8505	2460.0-02
TRUNK LID LIGHT, E33	6320.0-03
TRUNK LID LIGHT, LEFT, E9033	6320.0-03
TRUNK LID LIGHT, RIGHT, E9133	6320.0-03
TRUNK LID LOCKING SWITCH, S117	5126.0-01
TRUNK LID SWITCH, S81	6320.0-03
TRUNK LOCK MOTOR, M17	5126.0-02
TURN LIGHT, LEFT FRONT, H7	6313.0-02
TURN LIGHT, LEFT REAR, H6	6313.0-02
TURN LIGHT, RIGHT FRONT, H4	6313.0-02
TURN LIGHT, RIGHT REAR, H5	6313.0-02
TURN/HAZARD LIGHTS	6313.0
UNDERHOOD LIGHT, E20	6314.0-04
UNDERHOOD LIGHT SWITCH, S19	6314.0-04
UNLOADER RELAY, TERMINAL 15, K9	0670.2-04
UNLOADER RELAY, TERMINAL 61, K61	1230.0-00
UNLOADER RELAY, TERMINAL R, K3	0670.2-04
VEHICLE SPEED SENSOR, B10	6210.0-08
VENTILATION FLAP MOTOR, RIGHT, M33	6450.0-08
VENTILATION FLAP MOTOR, LEFT, M38	6450.0-09
WASHER FLUID LEVEL SWITCH, S64	6210.0-06
WASHER FLUID LEVEL SWITCH, S136	6210.0-06
WASHER JET HEATER, LEFT, E51	6169.0-00
WASHER JET HEATER, RIGHT, E52	6169.0-00
WASHER PUMP, M4	6160.0-02
WASHER PUMP RELAY, K5	6160.0-02
WATER PUMP, M37	6450.0-11
WATER PUMP IN LUGGAGE COMPARTMENT, M86	6167.0-02
WATER VALVE ASSEMBLY, Y4	6450.0-02
WINDOW LIMIT SWITCH, LEFT REAR, S45	5133.0-04

WINDOW LIMIT SWITCH, RIGHT REAR, S46	5133.0-04
WINDOW MOTOR, DRIVER'S, M21	5133.0-01
WINDOW MOTOR, LEFT REAR, M20	5133.0-04
WINDOW MOTOR, PASSENGER'S, M23	5133.0-03
WINDOW MOTOR, RIGHT REAR, M22	5133.0-04
WINDOW SWITCH, PASSENGER'S, S97	5133.0-02
WINDSHIELD WASHER JET HEATERS	6169.0
WIPER MOTOR, M3	6160.0-01
WIPER PRESSURE CONTROL (ADV) RELAY, K12	6164.0-01
WIPER PRESSURE CONTROL MOTOR (ADV), M6	6164.0-01
WIPER RELAY I, K36	6160.0-01
WIPER RELAY II, K37	6160.0-01
WIPER RELAY III, K38	6160.0-01
WIPER/WASHER SWITCH, S5	6160.0-00
ZKE CENTRAL LOCKING (ZV)	5126.0
ZKE DOOR LOCK HEATING (TSH)	5120.0
ZKE HEADLIGHT WASHER (SRA)	6167.0
ZKE INTERIOR LIGHTS (IB)	6330.0
ZKE POWER WINDOWS (FH)	5133.0
ZKE SUNROOF (SHD)	5410.0
ZKE WINDSHIELD WIPER PRESSURE CONTROL (ADV)	6164.0

Schematics

The schematics divide the entire vehicle electrical system into individual circuits. Interacting electrical components are shown on one common schematic.

Switches and other components are represented in such a way that their general layout and function are self-explicit. They are arranged on the sheet such that the current path can be followed from positive (top) to negative (bottom).

Important: The components and wires are not drawn to scale. For instance, a lead with a length of over 1m can be shown as a lead that is only a few cm long. To ensure clear arrangement, all connectors, lines branches and connected components from the fuses to the component and from the component to ground connection are not shown within the individual cells. If required, reference can be made to cells 0670.3 Fuse Details and 0670.4 Ground Distribution where all lines are illustrated with all plug connections, line branches and connected components.

All circuit symbols used are listed and explained in cell 0140.0 Symbols.

In cell 7000.0 Component Location Chart all important connectors, ground points and components are listed in tabular form. It provides a precise description of the component locations in the vehicle.

In cell 7100.0 Component Location Views the location of connectors and components which are difficult to locate are shown in line arts or illustrations. In cell 8000.0 Splice Location Views all splices are listed in numerical order and illustrations are provided to assist in locating splices on larger harnesses. In cell 8500.0 Connector Views diagrams of connectors with more than 2 pins are illustrated.

Included in this ETM are foldout block diagrams. These are overviews of the entire system (EGS, ABS, AC etc.) which helps understand the relationships between various components and control unit of the system being diagnosed.

Example

General conventions can be explained based on the following schematic example.

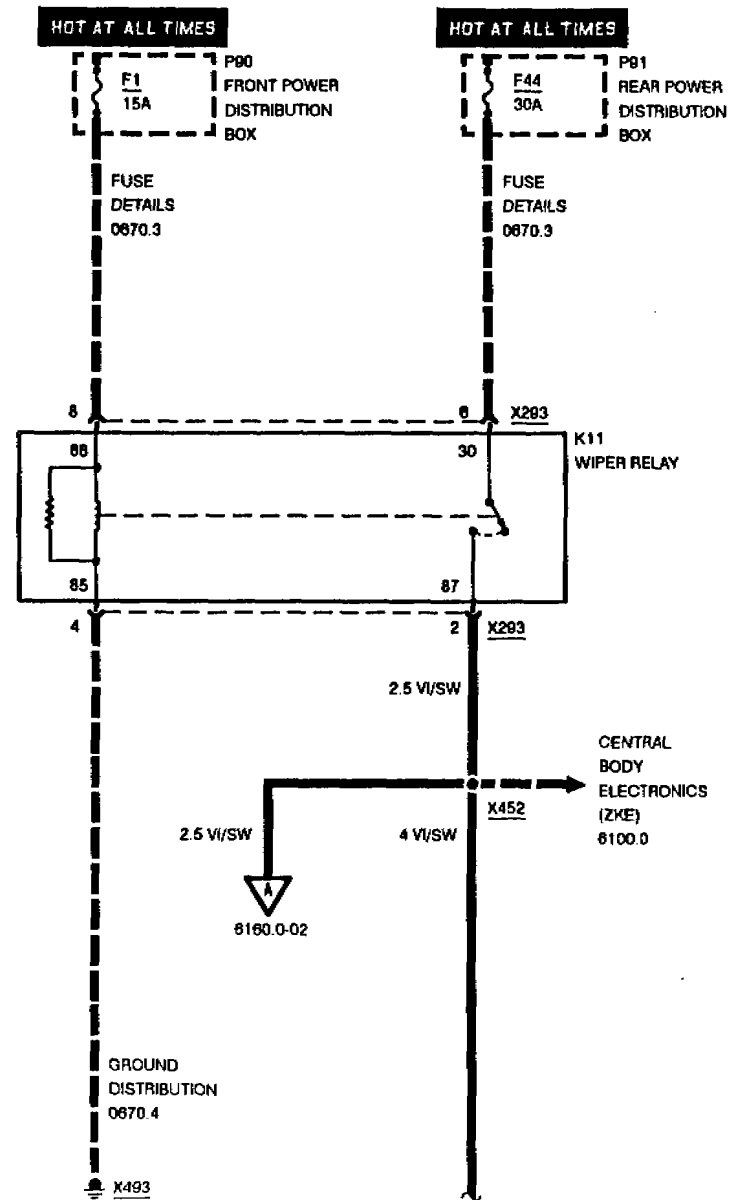



INTRODUCTION

General Conventions

1. Switches and relays are always shown in rest position (e.g. K11).
2. A component shown in a dashed frame signifies that the component is illustrated only in part (e.g. P90 and P91).
3. A component shown in a completely drawn frame signifies that the component is illustrated in full (e.g. K11).
4. The dashed line between pin 8 and pin 6 of connector X293 indicates that both pins belong to connector X293.
5. The dashed line from fuse F1 to pin 8 of connector X293 shows the positive supply of relay K11. If required, refer to cell 0670.3 Fuse Details at fuse F1 for the complete line progressing with plug connections, line branches, wire colors and cross sections.
6. The dashed line with an arrow at splice X452 indicates that several wires lead to splice X452. All lines leading to the connection are illustrated in cell 6100.0 Central Body Electronics (ZKE). An interrupted line with an arrow indicates that only this one wire leads to another circuit.
7. The dashed line from pin 4 of connector X293 to ground X493 shows the ground supply for relay K11. If required, refer to cell 0670.4 Ground Distribution at ground X493 for the complete line progression with all plug connections, line branches, wire colors and cross sections.
8. The interrupted line from splice X452 with an A in the open arrow is continued on page 6160.0-02. Termination of wire 4 V1/SW from splice X452 with a wavy line indicates that the wire is continued on the opposite page.

SYMBOLS



BATTERY



HEATING ELEMENT



VARIABLE RESISTANCE SENSOR
VARIABLE CONTACT IS
MOVED BY AN EXTERNAL
FORCE

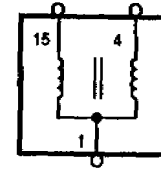

IGNITION COIL



FUSE DETAILS



LOUDSPEAKER OR HORN



VARIABLE RESISTOR
RESISTANCE IS CHANGED
BY TEMPERATURE OR
PRESSURE



CONTROL/POWER ELECTRONICS



FUSIBLE LINK



INDUCTIVE SENSOR



RADIO



LIGHT



DIODE
CURRENT CAN FLOW ONLY
IN DIRECTION OF ARROW

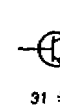

TRANSISTORIZED SWITCH



CIRCUIT BREAKER



PERMANENT MAGNET MOTOR
ONE SPEED



ZENER DIODE
TO REGULATE VOLTAGE



OXYGEN SENSOR



SOLENOID



PERMANENT MAGNET MOTOR
TWO SPEEDS



LIGHT EMITTING DIODE



VEHICLE SPEED SENSOR



SOLENOID CONTROLLED VALVE
OR CLUTCH SOLENOID



SYMBOLS

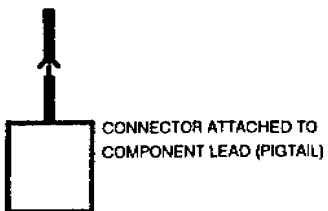
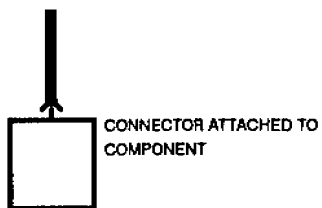
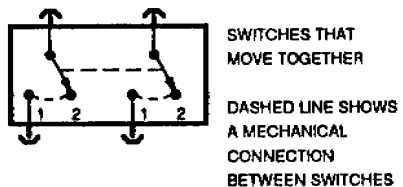
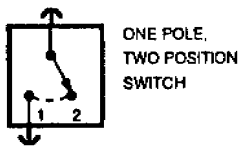
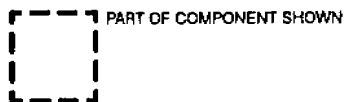
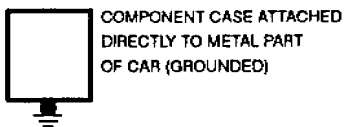

WIRE COLOR	
BL	BLUE
BR	BROWN
GE	YELLOW
GN	GREEN
GR	GRAY
OR	ORANGE
RS	PINK
RT	RED
SW	BLACK
VI	VIOLET
WS	WHITE
TR	TRANSPARENT

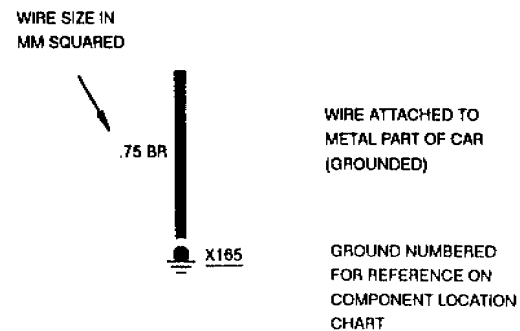
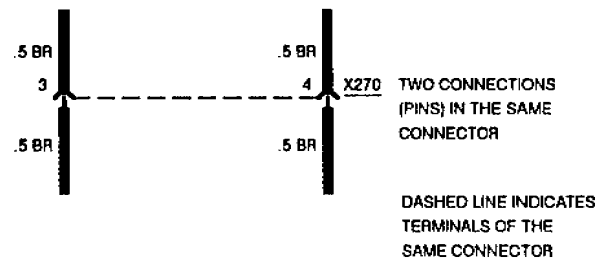
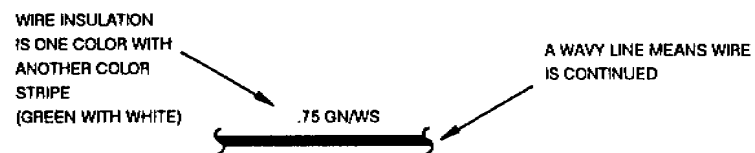
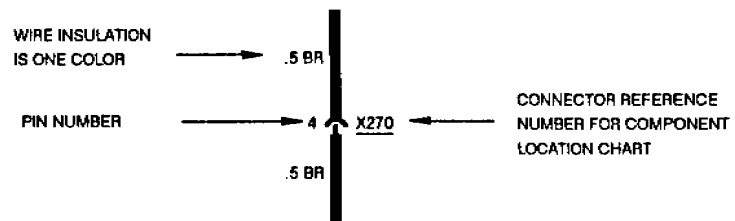

SYMBOLS

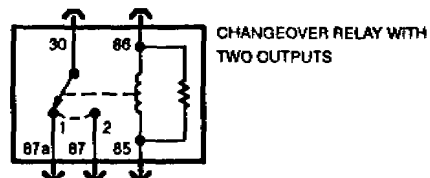
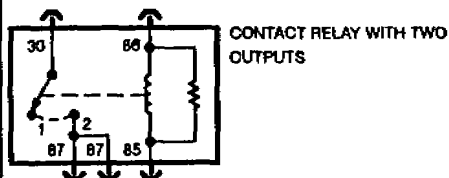
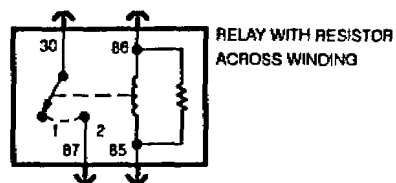
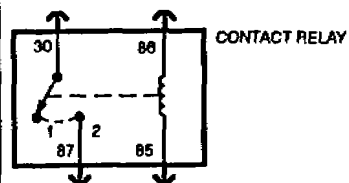

TERMINAL NUMBER	DESCRIPTION
30	RELAY INPUT
85	RELAY OUTPUT (WINDING)
86	RELAY INPUT (WINDING)
87	RELAY OUTPUT (ENERGIZED)
87a	RELAY OUTPUT (AT REST)

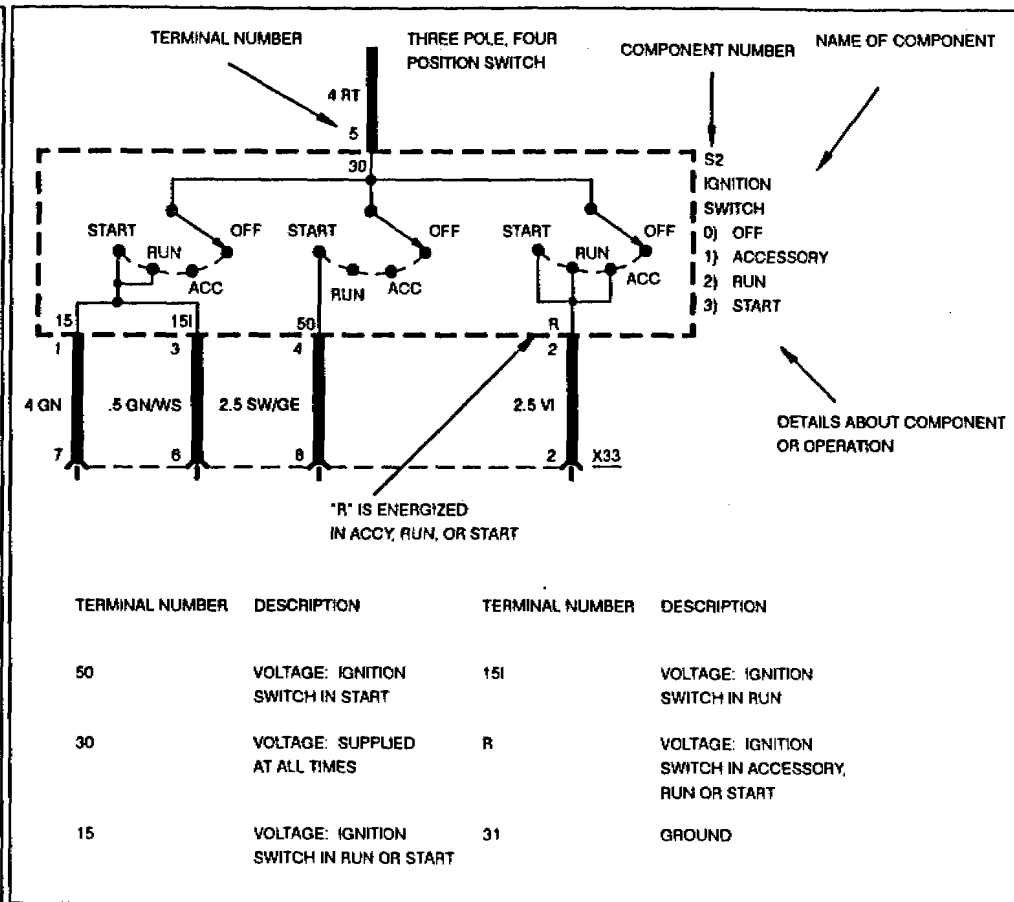

HDT AT ALL TIMES



INDICATES THAT FUSE 9 IS SUPPLIED WITH POWER AT ALL TIMES

POWER STATUS

HOT AT ALL TIMES

HOT IN RUN AND START

HOT IN ACCY, RUN AND START

DESCRIPTION

VOLTAGE: SUPPLIED AT ALL TIMES

VOLTAGE: IGNITION SWITCH IN RUN OR START

VOLTAGE: IGNITION SWITCH IN ACCESSORY, RUN OR START



SYMBOLS

HOT IN ACCY, RUN AND START

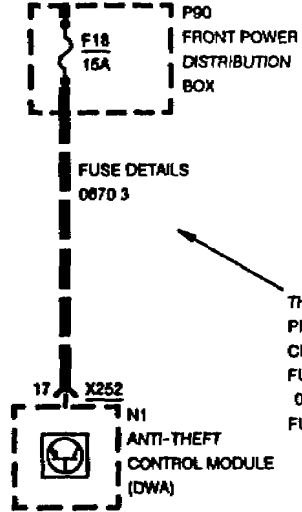

THE COMPLETE WIRE PROGRESSION AND FURTHER CIRCUITS CONNECTED TO FUSE 18 ARE SHOWN IN CELL 0670 3 FUSE DETAILS* AT FUSE 18

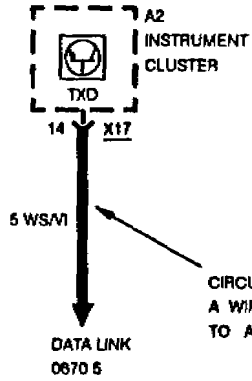

CIRCUIT REFERENCE- A WIRE WHICH CONNECTS TO ANOTHER CIRCUIT

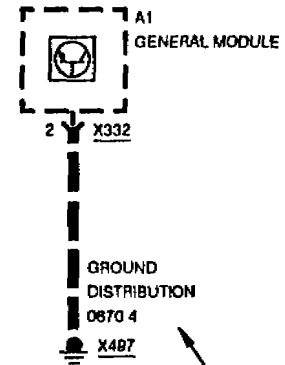

THE COMPLETE WIRE PROGRESSION AND FURTHER CIRCUITS CONNECTED TO GROUND X497 ARE SHOWN IN CELL 0670.4 GROUND DISTRIBUTION AT GROUND X497

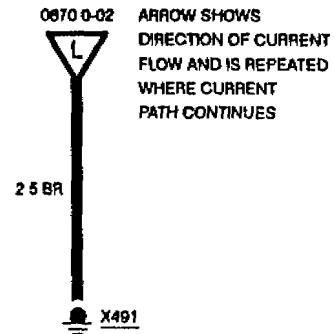
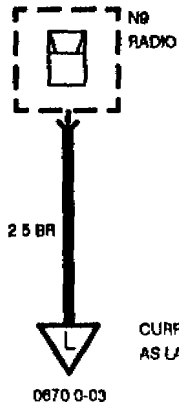

BMW
8 **SYMBOLS**
BLOCK DIAGRAM

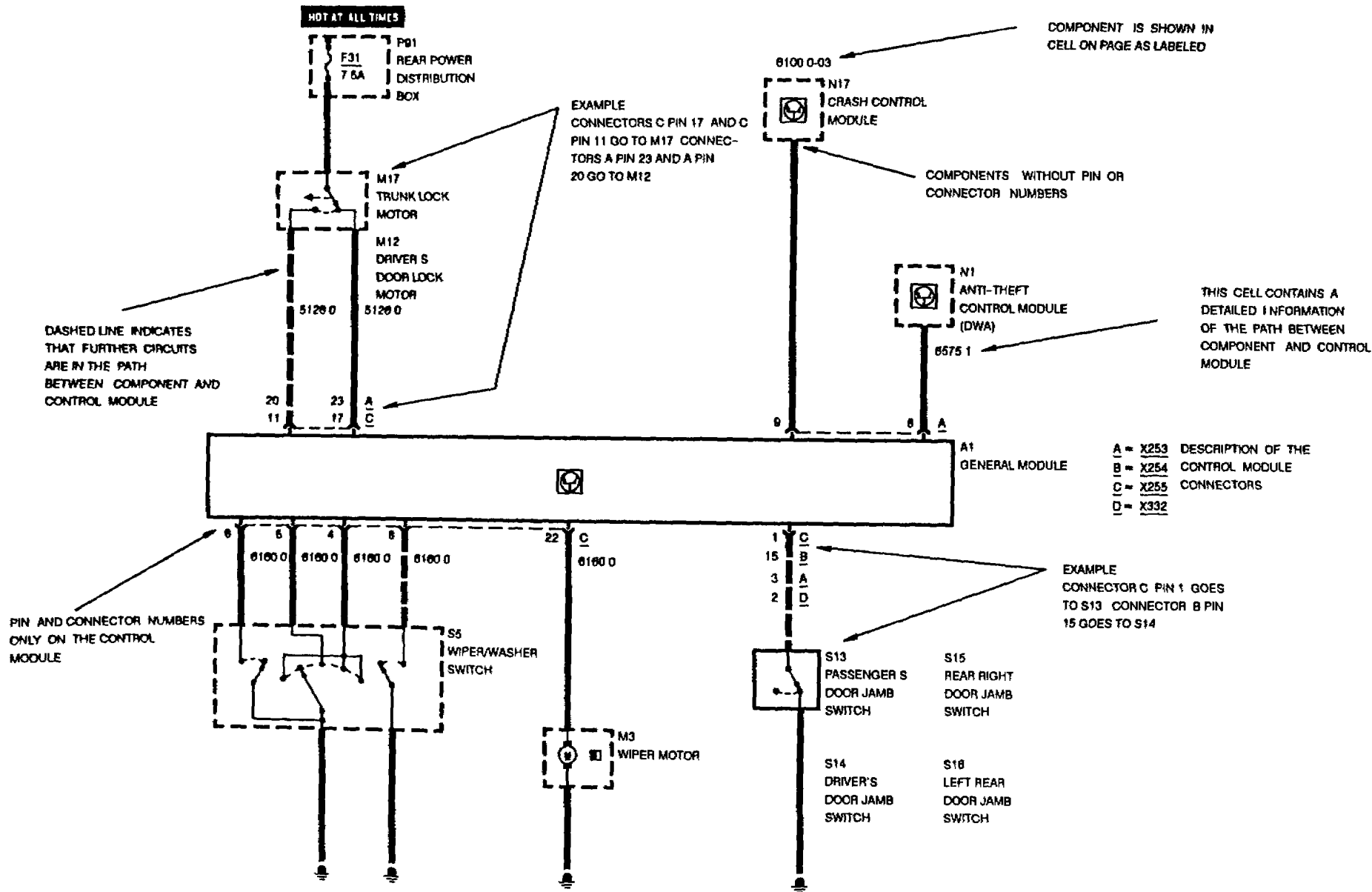

BMW
8

0670.0



POWER DISTRIBUTION CHART

FRONT POWER DISTRIBUTION BOX

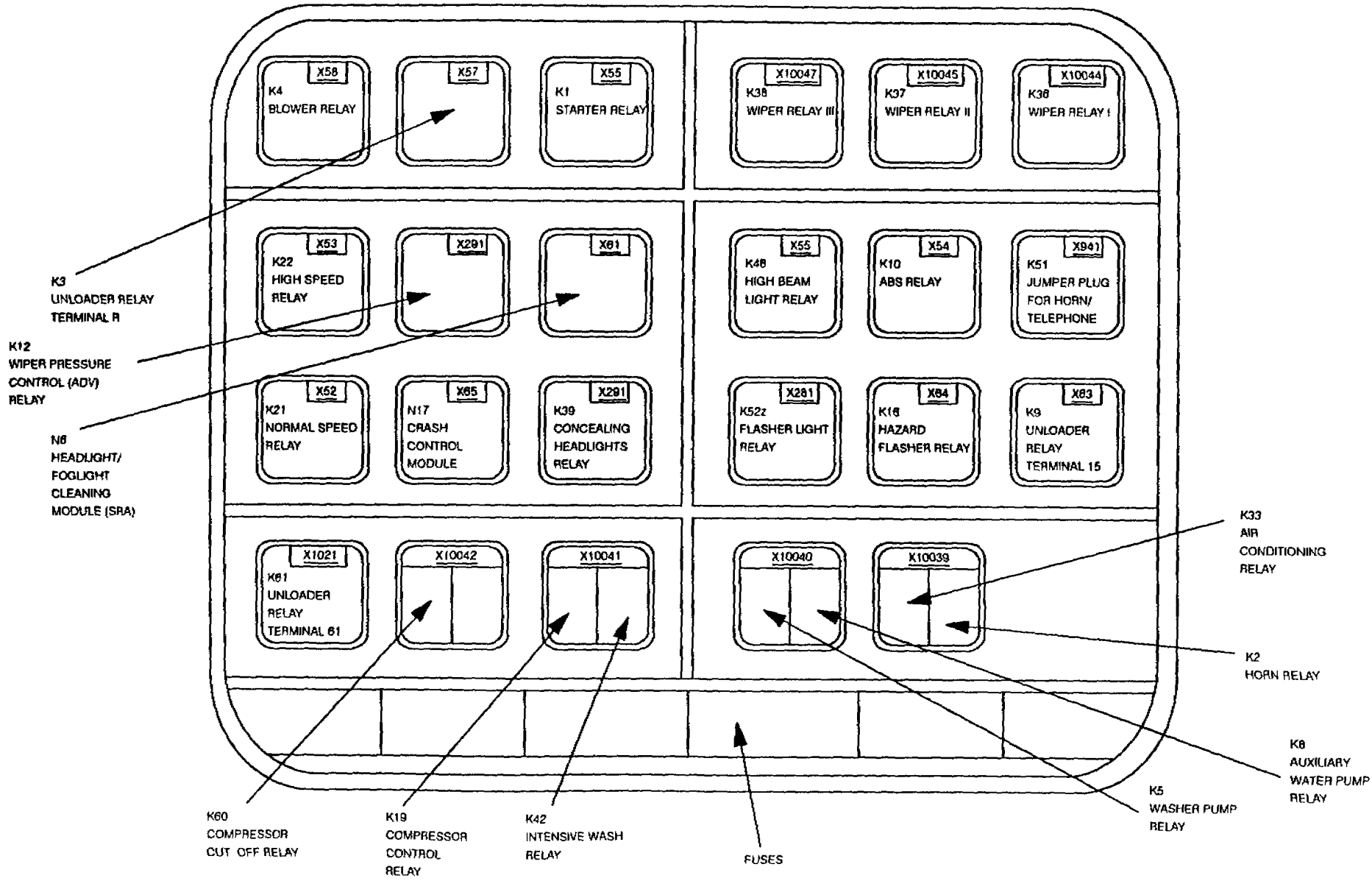

BMW 8 POWER DISTRIBUTION CHART REAR POWER DISTRIBUTION BOX

