



PARTS MANUAL

MAINTENANCE

FILTERS KIT



FIGURE	REFERENCE	DENOMINATION	AMOUNT
001	KF.57200RE00	C 350 H x2/x4 FILTERS KIT	1

ENGINE

ENGINE

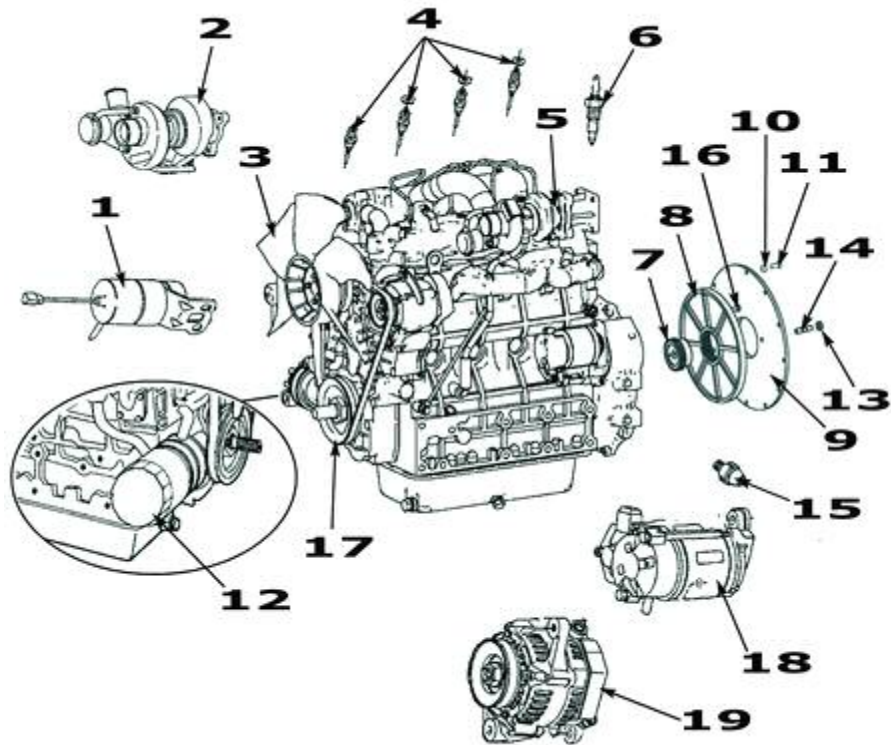

FIGURE	REFERENCE	DENOMINATION	AMOUNT
001	KU1C01060014	STOP SOLENOID	1
002	KU.10011.00	TURBO	1
003	KU.10007.00	FAN	1
004	KU.10003.00	HEATER	4
005	57.02100.00	ENGINE V3300 - E2B - AUSA 1	1
006	KU.10008.00	OVERHEAT WARNING SWITCH	1
007	57.02092.00	COUPLING	1
008	57.02091.00	COUPLING	1
009	57.02090.00	COUPLING	1
010	101.10000.66	WASHER DIN125	12
011	607.10025.90	SCREW	12
012	KU.10004.00	OIL FILTER CARTRIDGE	1
013	15.30110.00	WASHER 14X7X26	2
014	43.40129.00	STUD DIN939	1
015	KU.10009.00	OIL WARNING SWITCH	8
016	627.10035.86	SCREW	8

017	KU.10010.00	V BELT	1
018	KU.10002.00	STARTING ENGINE	1

**ENGINE
ENGINE**

FIGURE	REFERENCE	DENOMINATION	AMOUNT
019	KU.10001.00	ALTERNATOR	1

ENGINE EXHAUST

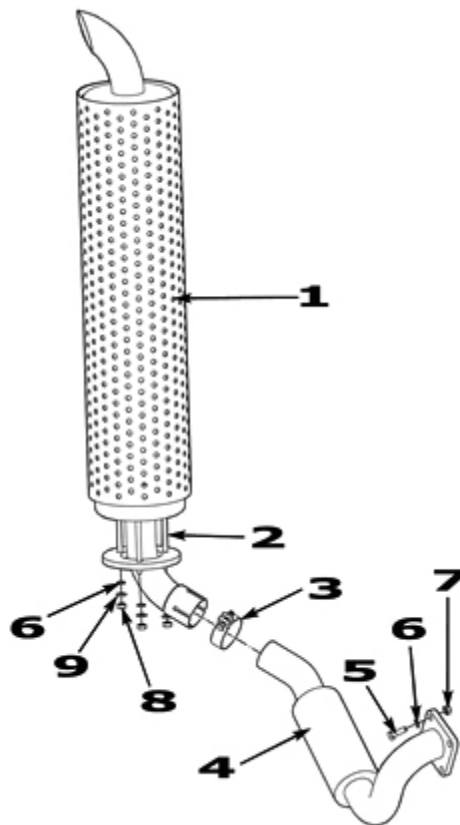

FIGURE	REFERENCE	DENOMINATION	AMOUNT
001	57.02020.00	EXHAUST	1
001	57.02023.00		1
001	57.02024.00		1
002	20.02020.00	FLANGE	1
003	935.47051.66	CLAMP	1
004	57.02022.00	ESCAPE COLLECTOR	1
005	603.08025.86	SCREW DIN933	4
006	104.08000.00	WASHER D8	7
007	708.10125.66	NUT	4
008	701.08000.66	NUT DIN934 M8X1,25	3
009	101.08000.66	WASHER DIN125	3

ENGINE AIR FILTER

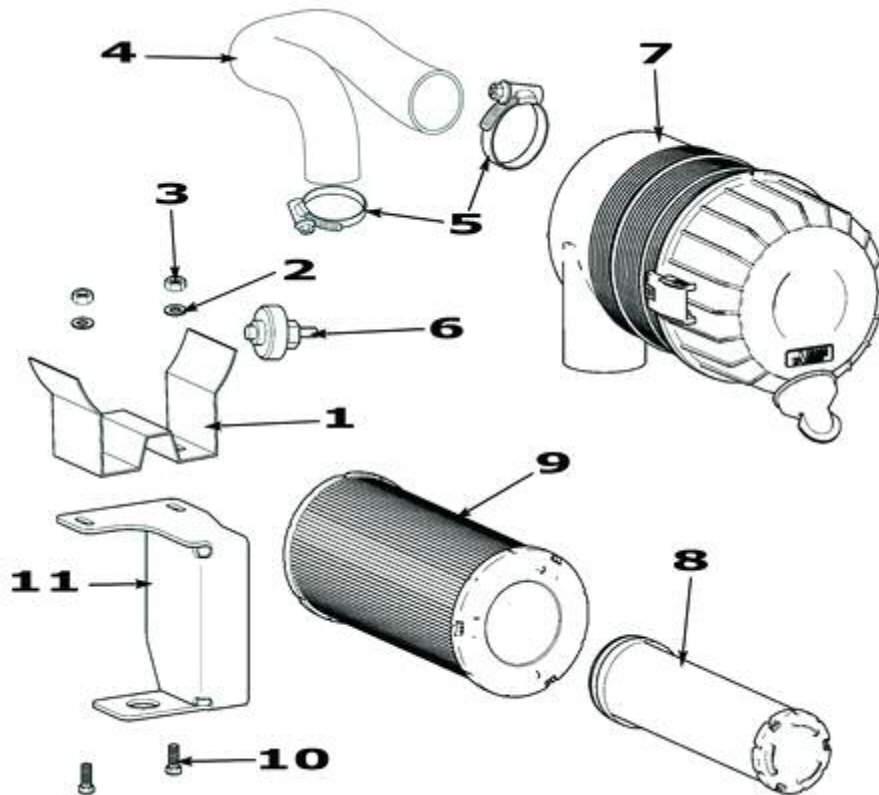

FIGURE	REFERENCE	DENOMINATION	AMOUNT
001	57.02030.00	SUPPORT	1
002	104.08000.00	WASHER D8	2
003	701.08000.66	NUT DIN934 M8X1,25	2
004	57.02058.00	TUBE	1
005	912.40060.66	CLAMP	2
006	43.50119.00	INDICATOR	1
007	43.01213.00	FILTER ELEMENT 8X140X320 A	1
008	43.01214.00	FILTER ELEMENT 60X80X318 A	1
009	43.01213.00	FILTER ELEMENT 8X140X320 A	1
010	603.08020.86	SCREW DIN933	2
011	43.01211.00	CLAMP	1

ENGINE ACCELERATOR PEDAL

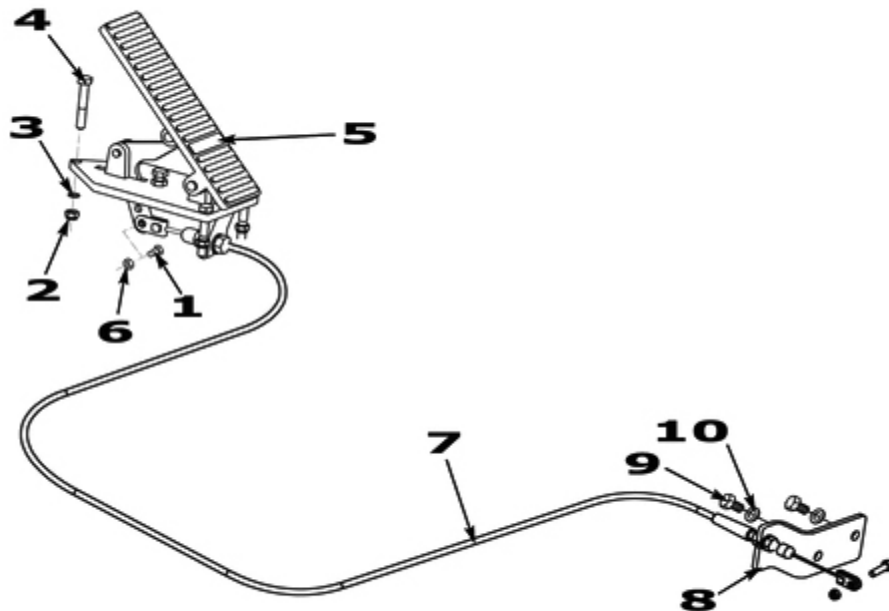

FIGURE	REFERENCE	DENOMINATION	AMOUNT
001	603.06020.86	SCREW DIN933	2
002	701.06000.66	NUT DIN934	3
003	104.06000.00	WASHER DIN7980 (D6)	3
004	603.06040.86	SCREW	3
005	12.02020.00	ACCELERATOR PEDAL VIMOTER	1
006	711.06000.66	NUT DIN982 M6	2
007	57.02041.00	CABLE 1925	1
008	64.02140.00	FIXATION SUPPORT	1
009	620.10020.86		2
010	104.10000.00	CIR-CLIP EXT. DIN7980	2

ENGINE

ACCELERATOR PEDAL

CHASSIS: 56534

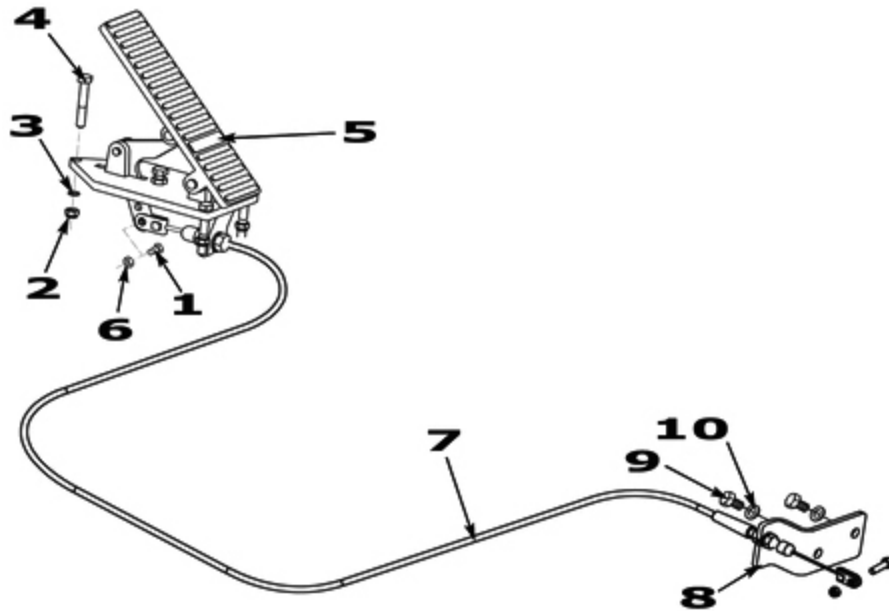

FIGURE	REFERENCE	DENOMINATION	AMOUNT
001	603.06020.86	SCREW DIN933	2
002	701.06000.66	NUT DIN934	3
003	104.06000.00	WASHER DIN7980 (D6)	3
004	603.06040.86	SCREW	3
005	12.02020.00	ACCELERATOR PEDAL VIMOTER	1
006	711.06000.66	NUT DIN982 M6	2
007	57.02041.00	CABLE 1925	1
008	64.02140.01	FIXATION SUPPORT	1
009	620.10020.86		2
010	104.10000.00	CIR-CLIP EXT. DIN7980	2

ENGINE FUEL TANK

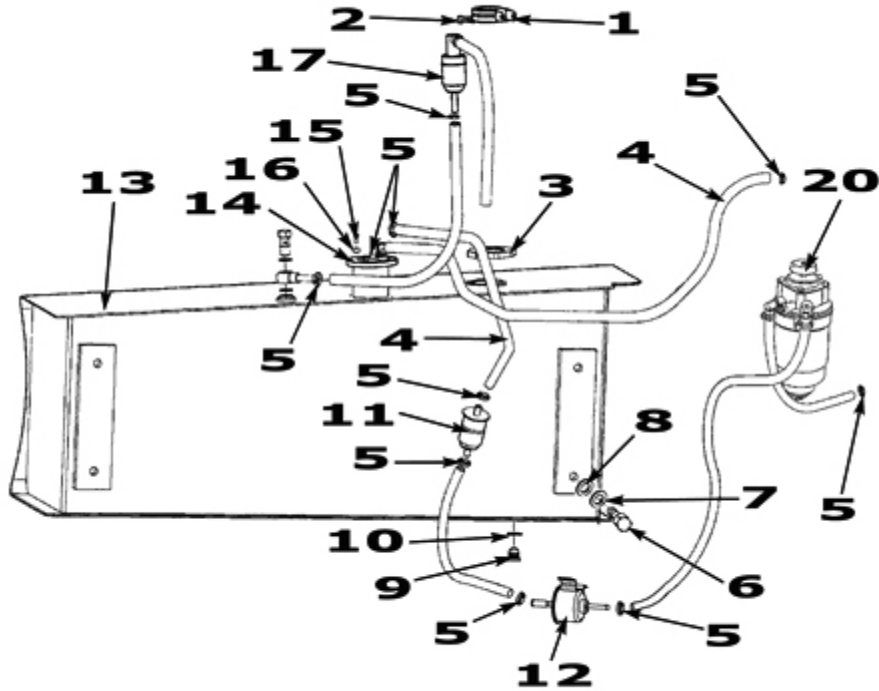

FIGURE	REFERENCE	DENOMINATION	AMOUNT
001	830.03006.00	CLAMP LOOP	1
002	603.06015.86	SCREW DIN933	1
003	15.01524.01	CAP WITH LOCK 40X72	1
004	469.03014.00	HOSE L/P MAT. 8X14	1
005	912.08016.66	CLAMP DIN3017	10
006	603.12020.86	SCREW DIN933	2
007	101.12000.66	WASHER DIN125	2
008	104.12000.00	CIR-CLIP EXT. DIN7980	2
009	10.00921.00	CAP	1
010	107.14000.10	WASHER	1
011	KU.10034.00	PRE-FILTER	1
012	KU.10033.00	ELECTRICAL FUEL PUMP	1
013	57.02040.00	FUEL TANK 85 L.	1
014	46.02048.00	GAS-OIL LEVEL	1
015	615.04020.66	SCREW DIN84	6
016	104.04000.00	WASHER D4	6



017	45.01526.00	FILTER FUEL	1
018	KU1K01143012	GAS-OIL FILTER	1