

Workshop Manual

Audi A3 1997 ▶

Booklet Electrical system

Edition 11.01

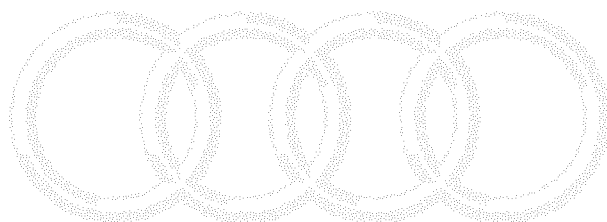

Audi

Protected by copyright. Copying for private or commercial purposes, in part or in whole, is not permitted unless authorised by AUDI AG. AUDI AG does not guarantee or accept any liability with respect to the correctness of information in this document. Copyright by AUDI AG.

erwin

Contents

27	Starter, Current supply	Page
	Battery	27-1
	– Notes on battery handling	27-3
	– Removing battery - Audi A3 up to Model Year 2000	27-4
	– Removing battery - Audi A3 as of Model Year 2001	27-7
	– Removing battery - Audi S3	27-9
	– Installing battery	27-13
	– Battery with magic eye	27-19
	– Visual inspection	27-21
	– Checking electrolyte level	27-22
	– No-load voltage measurement	27-27
	– Checking specific gravity of electrolyte of all cells	27-30
	– Measuring voltage under load	27-35
	– Charging battery	27-38
	Removing and installing alternator	27-43
	– 1.6 l and 1.8 l engine	27-44
	– 1.8l turbo engine - Audi A3	27-49
	– 1.8l turbo engine - Audi S3	27-55
	– 1.9l TDI engine - distributor-type injection pump	27-62
	– 1.9l TDI engine - UIS	27-69
	– Replacing voltage regulator - Bosch alternator	27-74
	– Replacing voltage regulator - Valeo alternator	27-75
	– Removing and installing ribbed belt pulley without free-wheel	27-76
	– Removing and installing ribbed belt pulley with free-wheel	27-78
	Removing and installing starter	27-80
	– Vehicles with 4-cylinder petrol engine	27-81
	– Vehicles with automatic gearbox 09A	27-85

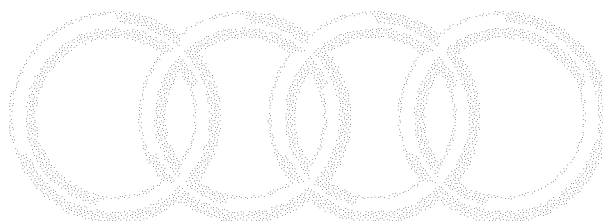

90	Gauges, Instruments	Page
	Dash panel insert - up to Model Year 1999	90-1
	– "dEF" display on trip recorder	90-2
	– Removing and installing dash panel insert	90-3
	– Assignment of dash panel insert lamps - Model Year 1997	90-5
	– Assignment of dash panel insert lamps - as of Model Year 1998	90-7
	– Multi-pin connectors at dash panel insert	90-9
	– Assignment of contacts at multi-pin connectors at dash panel insert - Model Year 1997	90-10
	– Assignment of contacts at multi-pin connectors at dash panel insert - as of Model Year 1998	90-15
	– Connection assignment at fuel-gauge sender	90-20
	– Terminal assignment at coolant temperature sender -G2	90-23
	– Radio clock	90-25
	Dash panel insert - as of Model Year 2000	90-26
	– "dEF" display on trip recorder	90-27
	– Removing and installing dash panel insert	90-28
	– Multi-pin connectors at dash panel insert	90-30
	– Assignment of contacts at multi-pin connectors at dash panel insert	90-31
	– Terminal assignment at coolant temperature sender -G2	90-38
	– Radio clock	90-39
92	Windscreen wipe and wash system	Page
	Servicing windscreen wiper system	92-1
	– Removing and installing windscreen wiper system	92-2
	– Adjusting park position of wiper blades	92-7
	– Eliminating wiper judder	92-8
	Servicing windscreen washer system	92-11
	– Removing and installing washer fluid reservoir	92-12
	– Removing and installing spray jets	92-15
	– Adjusting spray jets	92-17

Servicing rear window wipe/wash system	92-19
– Removing and installing rear wiper	92-20
– Removing and installing rear wiper motor	92-23
– Removing and installing spray jet	92-26
– Adjusting spray jet	92-27
– Adjusting park position of wiper blade	92-28
– Eliminating rear wiper judder	92-29
– Removing and installing washer fluid reservoir	92-32
Servicing headlight washer system	92-33
– Removing and installing spray jets of headlight washer system	92-34
– Adjusting spray jets	92-36
– Removing and installing washer fluid reservoir	92-36

94

Lights, Lamps, Switches - exterior	Page
Servicing headlights - up to Model Year 2000	94-1
– Exploded view of halogen headlight	94-2
– Exploded view of gas-discharge headlight	94-4
– Removing and installing headlights	94-7
– Adjusting headlights (halogen headlights)	94-11
– Adjusting headlights (gas-discharge headlights).....	94-12
– Preparation for headlight bulb replacement/replacement of headlight range control motor	94-16
– Replacing dipped beam bulb (halogen headlight)	94-17
– Replacing main beam bulb (halogen headlight)	94-18
– Replacing side light bulb (halogen headlight).....	94-20
– Replacing gas-discharge lamp for dipped beam (gas-discharge headlight).....	94-21
– Replacing main beam bulb (gas-discharge headlight).....	94-23
– Replacing side light bulb (gas-discharge headlight)	94-24
– Replacing turn signal indicator bulb	94-25
– Removing and installing headlight range control motor	94-27
– Removing and installing gas-discharge lamp starter unit -N195	94-28

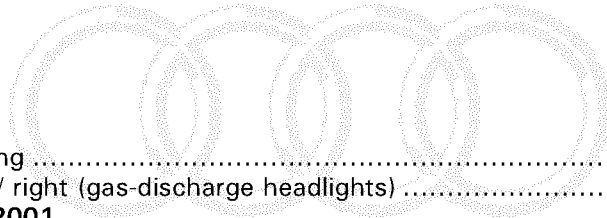

– Installing repair set for headlight housing	94-30
– Resetting headlights for driving on left/ right (gas-discharge headlights)	94-32
Servicing headlights - as of Model Year 2001	94-33
– Exploded view of halogen headlight	94-34
– Exploded view of gas-discharge headlight	94-36
– Removing and installing headlights	94-39
– Adjusting headlights (halogen headlights)	94-43
– Adjusting headlights (gas-discharge headlights).....	94-44
– Preparation for headlight bulb replacement/replacement of headlight range control motor	94-48
– Replacing dipped beam bulb (halogen headlight)	94-49
– Replacing main beam bulb (halogen headlight)	94-50
– Replacing side light bulb (halogen headlight)	94-51
– Replacing gas-discharge lamp for dipped beam (gas-discharge headlight).....	94-52
– Replacing main beam bulb (gas-discharge headlight).....	94-54
– Replacing side light bulb (gas-discharge headlight)	94-55
– Replacing turn signal indicator bulb	94-56
– Removing and installing headlight range control motor	94-57
– Removing and installing gas-discharge lamp starter unit -N195	94-58
– Installing repair set for headlight housing	94-61
– Resetting headlights for driving on left/ right	94-63
Servicing fog lights - up to Model Year 2000	94-64
– Removing and installing fog lights (halogen headlights)	94-65
– Replacing fog light bulbs (halogen headlights).....	94-66
– Adjusting fog lights (halogen headlights)	94-68
– Removing and installing fog lights (gas-discharge headlights)	94-69
– Replacing fog light bulbs (gas-discharge headlights)	94-71
– Adjusting fog lights (gas-discharge headlights).....	94-73
Servicing fog lights - vehicles as of Model Year 2001	94-74
– Removing and installing fog lights	94-75
– Replacing fog light bulbs.....	94-77

Protected by copyright. Copying for private or commercial purposes, in part or in whole, is not permitted unless authorised by AUDI AG. AUDI AG does not guarantee or accept any liability for the correctness of information in this document. Copyright by AUDI AG.

- Adjusting fog lights.....	94-79
Side-mounted turn signal indicators.....	94-81
- Removing and installing side-mounted turn signal indicator.....	94-82
Servicing rear lights.....	94-83
- Exploded view.....	94-84
- Removing and installing rear light.....	94-85
- Replacing bulbs for rear light.....	94-86
Servicing high-level brake light.....	94-87
- Removing and installing high-level brake light.....	94-88
Servicing number plate light.....	94-89
- Removing and installing number plate light.....	94-90
Steering column switch.....	94-92
- Safety precautions when working on airbag.....	94-93
- Removing and installing airbag unit.....	94-93
- Removing and installing steering column switch.....	94-94
- Terminal assignment at steering column switch.....	94-99
Servicing lock cylinder and ignition/starter switch.....	94-102
- Removing and installing lock cylinder.....	94-104
- Removing and installing ignition/starter switch.....	94-107
- Connection assignment at ignition/starter switch.....	94-108
Servicing parking aid.....	94-109
- Exploded view of parking aid.....	94-110
- Removing and installing parking aid control unit -J446.....	94-111
- Removing and installing rear parking aid warning buzzer -H15.....	94-113
- Removing and installing rear parking aid sender.....	94-115
Servicing automatic headlight range control.....	94-116
- Exploded view of automatic headlight range control.....	94-117
- Removing and installing headlight range control unit -J431 - 3-door model.....	94-119
- Removing and installing headlight range control unit -J431 - 5-door model.....	94-120
Servicing ultrasonic interior monitor.....	94-121

- Removing and installing ultrasonic sensors for interior monitor.....	94-122
- Removing and installing interior monitor control unit.....	94-123

96

Lights, Lamps, Switches - interior.....	Page
Servicing switches.....	96-1
- Removing and installing switches in centre console - up to Model Year 2000.....	96-2
- Removing and installing switches in centre console - as of Model Year 2001.....	96-3
- Removing and installing front seat heating switch - up to Model Year 2000.....	96-5
- Removing and installing front seat heating switch - as of Model Year 2001.....	96-6
- Removing and installing light switch.....	96-8
- Removing and installing adjuster for manual headlight range control.....	96-9
- Removing and installing switch for glove box light.....	96-10
- Removing and installing function selection switch.....	96-12
- Removing and installing mirror adjustment switch - 3-door model.....	96-13
- Removing and installing mirror adjustment switch - 5-door model.....	96-14
- Removing and installing window lifter switch - 3-door model.....	96-16
- Removing and installing driver's window lifter switch - 5-door model.....	96-17
- Removing and installing front passenger's window lifter switch - 5-door model.....	96-18
- Removing and installing rear door window lifter switch.....	96-19
- Removing and installing sun roof switch.....	96-20
- Removing and installing door contact switch.....	96-21
- Removing and installing front central locking switch.....	96-22
- Removing and installing button for interior monitor.....	96-23
- Removing and installing tailgate/boot lid contact switch - up to Model Year 2000.....	96-24
- Removing and installing tailgate/boot lid contact switch - as of Model Year 2001.....	96-25
Servicing immobilizer.....	96-26
- Defective transponder and/or loss of key.....	96-27
- Replacing reader coil.....	96-27
- Procedure for replacing lock set or dash panel insert.....	96-28
- System test.....	96-30

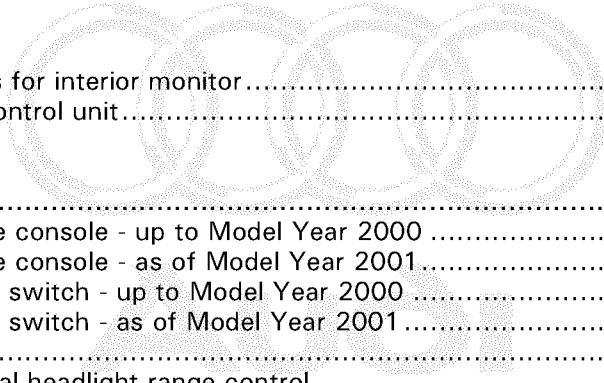

Protected by copyright. Copying for private or commercial purposes, in part or in whole, is not permitted without the express written consent of AUDI AG. AUDI AG does not guarantee or accept any liability with respect to the correctness of information in this document. Copyright by AUDI AG.

Servicing interior lights	96-32
– Removing and installing front interior light/reading light - up to Model Year 1999	96-33
– Replacing bulbs for front interior light/reading light - up to Model Year 1999	96-35
– Removing and installing front interior light/reading light - as of Model Year 2000	96-36
– Replacing bulbs for front interior light - as of Model Year 2000	96-39
– Replacing bulbs for front reading light - as of Model Year 2000	96-41
– Removing and installing rear interior light - up to Model Year 1999	96-43
– Replacing bulb for rear interior light - up to Model Year 1999	96-44
– Removing and installing rear interior light/reading light - as of Model Year 2000.....	96-45
– Replacing bulb for rear interior light/reading light - as of Model Year 2000	96-46
– Removing and installing luggage compartment lights	96-47
– Removing and installing glove box light	96-48
– Removing and installing make-up mirror light.....	96-49
– Removing and installing door safety light and entry light	96-50
Servicing lock cylinder heater	96-52
– Removing and installing lock cylinder heater control unit.....	96-53
Servicing horns	96-54
– Removing and installing horn	96-55
Servicing connection socket for towing hitch	96-56
– Removing and installing connection socket for towing hitch	96-57
– Terminal assignment at connection socket for towing hitch.....	96-58

97

Wiring	Page
Relay carriers, fuse carriers	97-1
– Removing and installing fuse box for main fuse.....	97-2
– Removing and installing fuse box.....	97-4
– Removing and installing central electrics and 13-position relay carrier	97-7
– Left connector point.....	97-9
– Right connector point	97-10
– Relay carrier at bulkhead on left.....	97-11

Wiring harness and connector repair	97-12
– General	97-13
– Repairing 0.22 mm ² / 0.35 mm ² wire	97-14
– Safety precautions for wiring harness and connector repair	97-17
– Replacing aerial wires.....	97-18

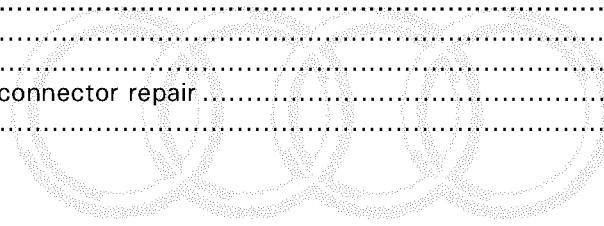

Audi

Protected by copyright. Copying for private or commercial purposes, in part or in whole, is not permitted unless authorised by AUDI AG. AUDI AG does not guarantee or accept any liability with respect to the correctness of information in this document. Copyright by AUDI AG.

erwin

Battery

The battery is one of the most important electrical components in the vehicle. Its proper functioning is a major factor in ensuring customer satisfaction. To guarantee a long service life, the battery must be checked, serviced and maintained as described in this manual.

In addition to its starting function, the battery acts as back-up and supplies power for the entire electrical system.

27-1

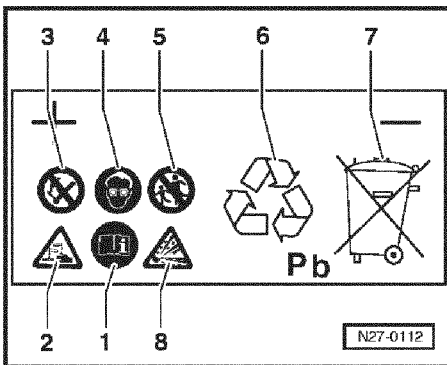

◀ Hazard warning information and safety regulations relating to lead-acid batteries

- - Pay attention to information given on battery, in electrical system workshop manual and in owner's manual.
- 2 - Danger of acid burns:
 - Electrolyte is highly corrosive; protective gloves and eye protection are therefore always to be worn.
 - Never tilt battery, as electrolyte may escape from vents.
- 3 - Fire, sparks, naked flames and smoking prohibited:
 - Take care to avoid sparks when handling cables and electrical equipment.
 - Take care to avoid short circuits.
- 4 - Wear eye protection.
- 5 - Keep electrolyte and batteries out of children's reach.
- 6 - Disposal:
 - Old batteries are to be taken to disposal site.
- 7 - Old batteries are never to be disposed of with domestic refuse.
- 8 - Danger of explosion:
 - Battery charging produces a highly explosive gas mixture.

27-2

Notes on battery handling

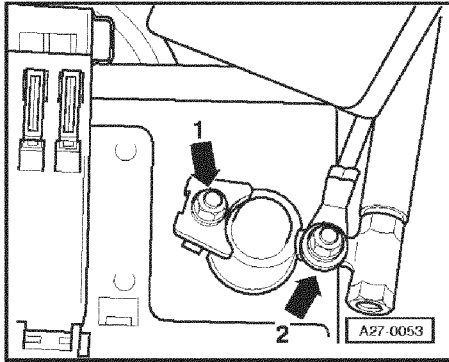

Notes:

- ◆ Battery posts are no longer to be greased.
- ◆ Battery terminals are only to be connected by hand without applying force so as not to damage the battery casing.
- ◆ Tightening torque for battery terminals: 6 Nm -arrow 1-
- ◆ Tightening torque of additional terminals at battery terminals: 6 Nm -arrow 2-

27-3

Removing battery – Audi A3 up to Model Year 2000

Attention:

On vehicles fitted with telematics system, activate telematics control-unit service mode before disconnecting battery. => Radio, Telephone, Navigation; Repair Group 91

- Heed (if necessary obtain) code for vehicles with encoded radio/radio navigation system (RNS).
- Switch off ignition.

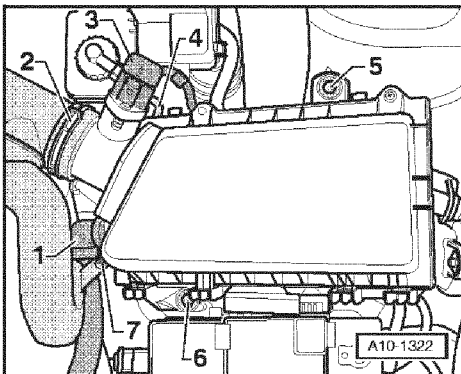

- ◆ - If fitted, disconnect air intake hose for secondary air pump -1- from air cleaner housing.
- If fitted, screw out bolt -7-.
- Detach air hose -2- at air-mass meter.
- Unplug connector -3- at air-mass meter.
- Screw out bolts -5- and -6-.

Protected by copyright. Copying for private or commercial purposes, in part or in whole, is not permitted unless authorised by AUDI AG. AUDI AG does not guarantee or accept any liability with respect to the correctness of information in this document. Copyright by AUDI AG.

27-4

- Take out air cleaner housing and detach breather hose -4- at rear if fitted.

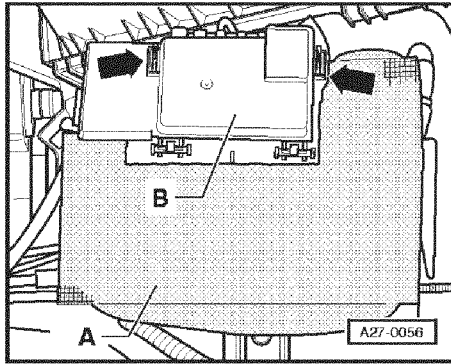

- ◀ - If fitted, open upper protective cover of battery -A- (velcro fastener).
- Press release tabs -arrows- and open lid -B- of main fuse box.

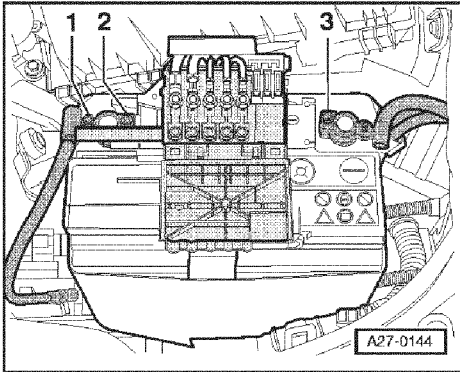

- ◀ - Unfasten nut -3- several turns and disconnect pole shoe of earth wire from battery post.
- Unscrew nut -1- and detach busbar for main fuse box at pole shoe of positive wire.
- Unfasten nut -2- several turns and disconnect pole shoe of positive wire from battery post.

27-5

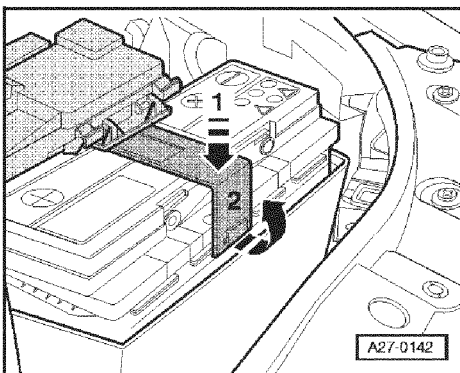

- ◀ - Release retainer for main fuse box. To do so, press down front edge of retainer -arrow 1- and at the same time detach retainer from battery in direction of travel -arrow 2-.
- Fold back main fuse box and lift off protective cover for battery.

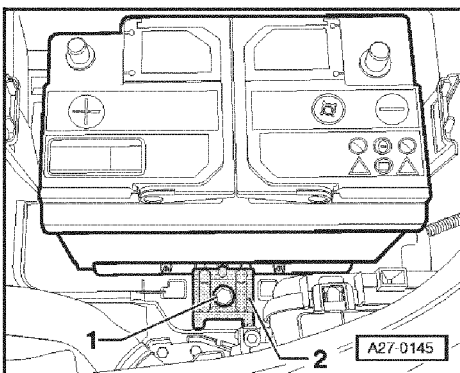

- ◀ - Screw out hexagon bolt -1- at battery bracket -2-.
- Pull battery out of fastening strip of battery bracket.
- Lift battery out of engine compartment.
- Install battery => Page 27-13.

Protected by copyright. Copying for private or commercial purposes, in part or in whole, is not permitted unless authorised by AUDI AG. AUDI AG does not guarantee or accept any liability with respect to the correctness of information in this document. Copyright by AUDI AG.

27-6

Removing battery – Audi A3 as of Model Year 2001

Attention:

On vehicles fitted with telematics system, activate telematics control-unit service mode before disconnecting battery. => Radio, Telephone, Navigation; Repair Group 91

– Heed (if necessary obtain) code for vehicles with encoded radio/radio navigation system (RNS).

– Switch off ignition.

– Remove cover -1- over battery. To do so, press both release tabs

-arrow-.

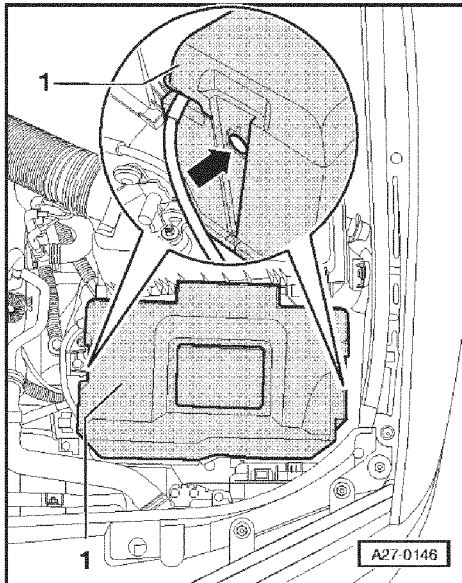

———— 27-7 ————

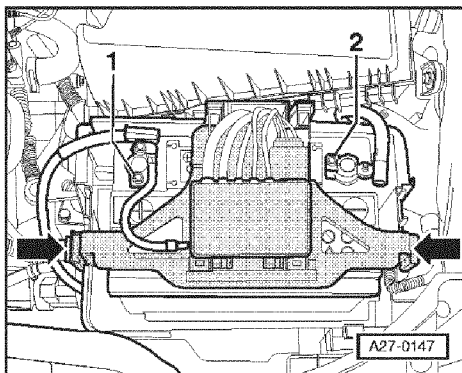

– Unfasten nut -2- several turns and disconnect pole shoe of earth wire from battery post.

– Unfasten nut -1- several turns and disconnect pole shoe of positive wire from battery post.

– Press release tabs -arrows- and fold back main fuse box.

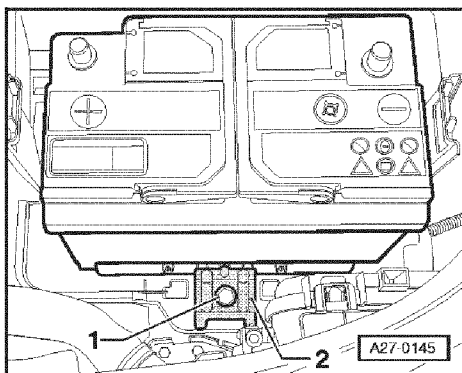

– Screw out hexagon bolt -1- at battery bracket -2-.

– Pull battery out of fastening strip of battery bracket.

– Lift battery out of engine compartment.

– Install battery => Page 27-13.

Protected by copyright. Copying for private or commercial purposes, in part or in whole, is not permitted unless authorised by AUDI AG. AUDI AG does not guarantee or accept any liability with respect to the correctness of information in this document. Copyright by AUDI AG.

———— 27-8 ————