

---

---



## FOREWORD

---

This Arctic Cat Service Manual contains service, maintenance, and troubleshooting information for certain 2011 Arctic Cat ROV (Recreational Off-Highway Vehicle) models (see cover). The complete manual is designed to aid service personnel in service-oriented applications.

This manual is divided into sections. Each section covers a specific vehicle component or system and, in addition to the standard service procedures, includes disassembling, inspecting, and assembling instructions. When using this manual as a guide, the technician should use discretion as to how much disassembly is needed to correct any given condition.

The service technician should become familiar with the operation and construction of each component or system by carefully studying this manual. This manual will assist the service technician in becoming more aware of and efficient with servicing procedures. Such efficiency not only helps build consumer confidence but also saves time and labor.

All Arctic Cat publications and decals display the words Warning, Caution, Note, and At This Point to emphasize important information. The symbol  **WARNING** identifies personal safety-related information. Be sure to follow the directive because it deals with the possibility of serious personal injury or even death. A **CAUTION** identifies unsafe practices which may result in vehicle-related damage. Follow the directive because it deals with the possibility of damaging part or parts of the vehicle. The symbol  **NOTE:** identifies supplementary information worthy of particular attention. The symbol  **AT THIS POINT** directs the technician to certain and specific procedures to promote efficiency and to improve clarity.

At the time of publication, all information, photographs, and illustrations were technically correct. Some photographs used in this manual are used for clarity purposes only and are not designed to depict actual conditions. Because Arctic Cat Inc. constantly refines and improves its products, no retroactive obligation is incurred.

All materials and specifications are subject to change without notice.

Keep this manual accessible in the shop area for reference.

**Product Service and  
Warranty Department  
Arctic Cat Inc.**

## **TABLE OF CONTENTS**

Note: To navigate through this manual, use the PAGE UP/PAGE DOWN buttons on the keyboard, click on the Table of Contents bookmarks on the left side of the screen, or click the blue text below. To return to this page, click the Manual Table of Contents button at the bottom of each page.

<b>1. General Information/Specifications</b>	<b>1</b>
<b>2. Periodic Maintenance/Tune-Up</b>	<b>2</b>
<b>3. Engine/Transmission</b>	<b>3</b>
<b>4. Fuel/Lubrication/Cooling</b>	<b>4</b>
<b>5. Electrical System</b>	<b>5</b>
<b>6. Drive System</b>	<b>6</b>
<b>7. Suspension</b>	<b>7</b>
<b>8. Steering/Frame</b>	<b>8</b>
<b>9. Controls/Indicators</b>	<b>9</b>

*Prowler XT  
Prowler XT  
Prowler XTZ*



# SECTION 1 - GENERAL INFORMATION

---

---

## TABLE OF CONTENTS

---

General Specifications .....	1-2
Torque Specifications .....	1-2
Torque Conversions (ft-lb/N-m) .....	1-4
Tightening Torque (General Bolts) .....	1-4
Break-In Procedure .....	1-4
Gasoline - Oil - Lubricant .....	1-4
Genuine Parts .....	1-5
Preparation For Storage .....	1-5
Preparation After Storage.....	1-6

## General Specifications

CHASSIS		
Dry Weight (approx)	(XT) (XTX) (XTZ)	558 kg (1230 lb) 567 kg (1251 lb) 596 kg (1315 lb)
Length (overall)		301.5 cm (118.7 in.)
Height (overall)		201 cm (79 in.)
Width (overall)		156.2 cm (61.5 in.)
Suspension Travel		25.4 cm (10 in.)
Brake Type		Hydraulic
Wheelbase		190 cm (75 in.)
Tire Size - XT/XTX	(front) (rear)	26 x 9R-14 26 x 11R-14
Tire Size - XTZ	(front) (rear)	27 x 9R-14 27 x 11R-14
Tire Inflation Pressure - XT/XTX		0.70 kg/cm <sup>2</sup> (10 psi)
Tire Inflation Pressure - XTZ	(front) (rear)	0.84 kg/cm <sup>2</sup> (12 psi) 0.84-1.41 kg/cm <sup>2</sup> (12-20 psi)
MISCELLANY		
Gas Tank Capacity		31 L (8.2 U.S. gal.)
Coolant Capacity	(H1) (H2)	2.9 L (3.0 U.S. qt) 3.3 L (3.5 U.S. qt)
Front Differential Capacity		275 ml (9.3 fl oz)*
Rear Drive Capacity		250 ml (8.5 fl oz)*
Engine Oil Capacity	(H1) (H2)	2.5 L (2.6 U.S. qt) - Overhaul 1.9 L (2.0 U.S. qt) - Change 2.6 L (2.45 U.S. qt) - Overhaul 2.1 L (2.25 U.S. qt) - Change
Gasoline (recommended)		87 Octane Regular Unleaded
Engine Oil (recommended)		Arctic Cat ACX All Weather Synthetic
Front Differential/Rear Drive Lubricant		SAE Approved 80W-90 Hypoid
Belt Width		35.0 mm (1.38 in.)
Brake Fluid		DOT 4
Taillight/Brakelight		12V/8W/27W
Headlight		12V/27W (4)

Specifications subject to change without notice.

\* Visible at plug threads.

## Torque Specifications

NOTE: Torque specifications have the following tolerances:

Torque (ft-lb)	Tolerance
0-15	±20%
16-39	±15%
40+	±10%

EXHAUST COMPONENTS			
Part	Part Bolted To	Torque	
		ft-lb	N-m
Exhaust Pipe	Cylinder Head	20	27
Spark Arrester	Muffler	48 in.-lb	5

ELECTRICAL COMPONENTS			
Part	Part Bolted To	Torque	
		ft-lb	N-m
Coil*	Frame	8	11
Ground Wire	Engine	8	11

CHASSIS/ROPS ASSEMBLY			
Part	Part Bolted To	Torque	
		ft-lb	N-m
Shift Lever*	Shift Axle Bracket	20	27
Front/Rear ROPS Tube	Arm Rest/Steering Post Support	20	27
Top ROPS Support	Front/Rear ROPS Tubes	8	11
Rear ROPS Tube	Lower ROPS Support	8	11

STEERING COMPONENTS			
Part	Part Bolted To	Torque	
		ft-lb	N-m
Steering Wheel**	Steering Wheel Shaft	25	34
Steering Wheel Shaft***	Intermediate Shaft (Upper)	36	49
Intermediate Shaft (Lower)*** - XT	Steering Pinion Shaft	36	49
Rack and Pinion Assembly - XT	Frame	50	68
Rack and Pinion Assembly - XTX/XTZ	Frame	35	48
Tie Rod** - XT	Rack	52	70
Tie Rod** - XTX/XTZ	Rack	37	50
Tie Rod End**	Knuckle	30	41
Jam Nut	Tie Rod End	10	14
EPS Assembly - XTX/XTZ	Frame	35	48
EPS Assembly - XTX/XTZ	Rack Coupler	11	15
Intermediate Shaft Coupler	Intermediate Shaft	31	42
Intermediate Shaft (lower) - XTX/XTZ	EPS Input Shaft	11	15
Steering Shaft Housing (6 mm) - XTX/XTZ	Frame	8	11
Steering Shaft Housing (8 mm) - XTX/XTZ	Frame	20	27
SUSPENSION COMPONENTS (Front)			
A-Arm	Frame	33	45
Knuckle	Ball Joint	35	48
Shock Absorber	Frame/Upper A-Arm	33	45
Knuckle	A-Arm	35	48
SUSPENSION COMPONENTS (Rear)			
Sway Bar Bracket	Frame	33	45
A-Arm	Frame	33	45
Shock Absorber (Lower) - XT/XTX	Lower A-Arm	20	27
Shock Absorber (Lower) - XTZ	Frame	33	45
Shock Absorber (Upper)	Frame	33	45
Knuckle	A-Arm	35	48
Cargo Box Hinge	Cargo Box Frame	20	27
Cargo Box	Cargo Box Frame	20	27
Latch Pivot Bushing	Cargo Box Frame	15	20
Latch Striker	Cargo Box Liner	60 in.-lb	7
BRAKE COMPONENTS			
Brake Disc**	Hub	15	20
Brake Hose	Caliper	20	27
Brake Hose	Master Cylinder	20	27
Master Cylinder	Frame	25	34
Caliper Holder****	Knuckle	20	27
Brake Caliper****	Gear Case Housing	20	27
Brake Caliper	Rear Drive Housing	20	27
Driveline	Rear Drive Input Flange	20	27
Parking Brake Actuator Lever	Caliper	20	27
Parking Brake Caliper Assembly	Rear Drive Housing	20	27

\* w/Blue Loctite #243

\*\*\* w/Green Loctite #270

\*\* w/Red Loctite #271

\*\*\*\* w/"Patch-Lock"

www.mymowerparts.com

DRIVE TRAIN COMPONENTS			
Part	Part Bolted To	Torque	
		ft-lb	N-m
Rear Differential/Gear Case	Frame	38	48
Drive Coupler (Front)	Drive Flange	40	54
Front Engine Mounting Bracket	Frame	45	61
Rear Engine Mounting Bracket	Frame	45	61
Engine Mounting Through-Bolt	Frame	40	54
Front Differential	Frame/Differential Bracket	38	52
Rear Output Flange	Rear U-Joint Flange	40	54
Input Shaft Assembly	Gear Case Housing	23	31
Pinion Housing	Differential Housing	23	31
Differential Housing Cover***	Differential Housing	23	31
Drive Bevel Gear Nut***	Shaft	87	118
Lock Collar	Differential Housing	125	170
Hub Nut	Front/Rear Shaft/Axle (min)	200	272
Oil Drain Plug	Front Differential - Rear Drive	45 in.-lb	5
Oil Fill Plug	Front Differential - Rear Drive	16	22
Oil Drain Plug	Engine	16	22
Wheel (Aluminum)	Hub	80	108
Wheel (Steel)	Hub	45	61
Front Input Drive Flange	Front U-Joint	20	27
ENGINE/TRANSMISSION - H1			
Clutch Shoe**	Crankshaft	221	300
Clutch Cover/Housing Assembly	Crankcase	8	11
Crankcase Half (6 mm)	Crankcase Half	10	14
Crankcase Half (8 mm)	Crankcase Half	20	27
Cylinder Head (Cap Screw)	Crankcase	40	54
Cylinder Head Nut (6 mm)	Cylinder	8	11
Cylinder Head Nut (8 mm)	Cylinder	18	24
Valve Cover	Cylinder Head	8.5	11.5
Driven Pulley Nut	Driveshaft	80	109
Movable Drive Face Nut**	Driveshaft	165	224
Ground Wire	Engine	8	11
Magneto Cover	Crankcase	8	11
Tappet Cover	Valve Cover	9	12
Crankshaft Spacer	Crankshaft	28	38
Oil Pump Cover**	Crankcase	8	11
Oil Pump Drive Gear**	Crank Balancer Shaft	62	84
Output Shaft Flange Nut	Output Shaft**	62	84
Outer Magneto Cover	Magneto Cover	8	11
Magneto Rotor Nut**	Crankshaft	105	143
Cam Sprocket**	Camshaft	11	15
Speed Sensor Housing	Crankcase	8	11
V-Belt Cover	Crankcase	8	11
Output Yoke Nut	Secondary Driven Output Shaft	74	100
Output Shaft Flange Yoke/Nut	Output Shaft**	59	80
Secondary Shaft Bearing Housing	Crankcase Half	28	38
Stator Coil*	Magneto Cover	8.5	11.5
Intake Boot Clamp	Intake Boot	30 in.-lb	3.4

ENGINE/TRANSMISSION - H2			
Part	Part Bolted To	Torque	
		ft-lb	N-m
Clutch Shoe**	Crankshaft	221	300
Clutch Cover/Housing Assembly	Crankcase	8	11
Lower Crankcase Cover (6 mm)	Crankcase	8	11
Lower Crankcase Cover (8 mm)	Crankcase	20	27
Crankcase Half	Crankcase Half	8	11
Cylinder Head (Cap Screw)	Crankcase	38	52
Cylinder Head Nut (6 mm)	Cylinder	8	11
Cylinder Head Nut (8 mm)	Cylinder	18	24
Valve Cover	Cylinder Head	8.5	11.5
Driven Pulley Nut**	Driveshaft	80	109
Movable Drive Face Nut**	Driveshaft	165	224
Ground Wire	Engine	8	11
Magneto Cover	Crankcase	8	11
Tappet Cover	Valve Cover	9	12
Crankshaft Spacer	Crankshaft	28	38
Oil Pump Drive Gear**	Crank Balancer Shaft	62	84
Output Shaft Flange Yoke/Nut	Output Shaft**	59	80
Outer Magneto Cover	Magneto Cover	8	11
Rotor/Flywheel Nut**	Crankshaft	105	143
Cam Sprocket**	Camshaft	11	15
CVT Cover	Crankcase	8	11
Secondary Drive Gear Nut**	Secondary Drive Output Shaft	74	100
Oil Filter Cover	Crankcase	8	11
Speed Sensor Housing	Crankcase	8	11
Shift Cam Stopper	Crankcase	8	11
Shift Cam Stopper Spring	Shift Cam Stopper	8	11
Shift Cam Plate	Shift Cam Shaft	8	11
Shifter Housing	Crankcase	8	11
Starter Motor	Crankcase	8	11
V-Belt Cover	Crankcase	8	11
Oil Pump Cover**	Crankcase	8	11
Oil Strainer Cap	Crankcase	8	11
Stator Coil*	Magneto Cover	8.5	11.5
Intake Boot Clamp	Intake Boot	30 in.-lb	3.4

\* w/Blue Loctite #243

\*\* w/Red Loctite #271

\*\*\* w/Green Loctite #270

1

## Torque Conversions (ft-lb/N-m)

ft-lb	N-m	ft-lb	N-m	ft-lb	N-m	ft-lb	N-m
1	1.4	26	35.4	51	69.4	76	103.4
2	2.7	27	36.7	52	70.7	77	104.7
3	4.1	28	38.1	53	72.1	78	106.1
4	5.4	29	39.4	54	73.4	79	107.4
5	6.8	30	40.8	55	74.8	80	108.8
6	8.2	31	42.2	56	76.2	81	110.2
7	9.5	32	43.5	57	77.5	82	111.5
8	10.9	33	44.9	58	78.9	83	112.9
9	12.2	34	46.2	59	80.2	84	114.2
10	13.6	35	47.6	60	81.6	85	115.6
11	15	36	49	61	83	86	117
12	16.3	37	50.3	62	84.3	87	118.3
13	17.7	38	51.7	63	85.7	88	119.7
14	19	39	53	64	87	89	121
15	20.4	40	54.4	65	88.4	90	122.4
16	21.8	41	55.8	66	89.8	91	123.8
17	23.1	42	57.1	67	91.1	92	125.1
18	24.5	43	58.5	68	92.5	93	126.5
19	25.8	44	59.8	69	93.8	94	127.8
20	27.2	45	61.2	70	95.2	95	129.2
21	28.6	46	62.6	71	96.6	96	130.6
22	29.9	47	63.9	72	97.9	97	131.9
23	31.3	48	65.3	73	99.3	98	133.3
24	32.6	49	66.6	74	100.6	99	134.6
25	34	50	68	75	102	100	136

## Tightening Torque (General Bolts)

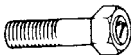
Type of Bolt	Thread Diameter A (mm)	Tightening Torque
(Conventional or 4 Marked Bolt) 	5	12-36 in.-lb
	6	36-60 in.-lb
	8	7-11 ft-lb
	10	16-25 ft-lb
(7 Marked Bolt) 	5	24-48 in.-lb
	6	6-8 ft-lb
	8	13-20 ft-lb
	10	29-43 ft-lb

## Break-In Procedure

A new vehicle and an overhauled engine require a “break-in” period. The first 10 hours (or 200 miles) are most critical to the life of this vehicle. Proper operation during this break-in period will help assure maximum life and performance from the vehicle.

During the first 10 hours (or 200 miles) of operation, always use less than 1/2 throttle. Varying the engine RPM during the break-in period allows the components to “load” (aiding the mating process) and then “unload” (allowing components to cool). Although it is essential to place some stress on the engine components during break-in, care should be taken not to overload the engine too often. Do not pull a trailer or carry heavy loads during the 10-hour break-in period.

When the engine starts, allow it to warm up properly. Idle the engine several minutes until the engine has reached normal operating temperature. Do not idle the engine for excessively long periods of time.

During the break-in period, a maximum of 1/2 throttle is recommended; however, brief full-throttle accelerations and variations in driving speeds contribute to good engine break-in.

After the completion of the break-in period, the engine oil and oil filter should be changed. Other maintenance after break-in should include checking of all prescribed adjustments and tightening of all fasteners (see Periodic Maintenance Chart in Section 2).

## Gasoline - Oil - Lubricant

### RECOMMENDED GASOLINE

The recommended gasoline to use is 87 minimum octane regular unleaded. In many areas, oxygenates (either ethanol or MTBE) are added to the gasoline. Oxygenated gasolines containing up to 10% ethanol, 5% methane, or 5% MTBE are acceptable gasolines.

When using ethanol blended gasoline, it is not necessary to add a gasoline antifreeze since ethanol will prevent the accumulation of moisture in the fuel system.

### CAUTION

**Do not use white gas. Only Arctic Cat approved gasoline additives should be used.**

## RECOMMENDED ENGINE/ TRANSMISSION OIL

### CAUTION

Any oil used in place of the recommended oil could cause serious engine damage. Do not use oils which contain graphite or molybdenum additives. These oils can adversely affect clutch operation. Also, not recommended are racing, vegetable, non-detergent, and castor-based oils.

The recommended oil to use is Arctic Cat ACX All Weather synthetic engine oil, which has been specifically formulated for use in this Arctic Cat engine. Although Arctic Cat ACX All Weather synthetic engine oil is the only oil recommended for use in this engine, use of any API certified SM 5W-50 oil is acceptable.

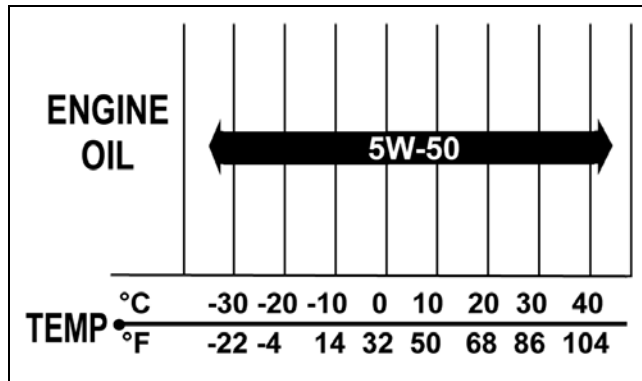

OILCHART1

## RECOMMENDED FRONT DIFFERENTIAL/REAR DRIVE LUBRICANT

The recommended lubricant is Arctic Cat Gear Lube or an equivalent gear lube which is SAE approved 80W-90 hypoid. This lubricant meets all of the lubrication requirements of the Arctic Cat vehicle front differential and rear drive.

### CAUTION

Any lubricant used in place of the recommended lubricant could cause serious front differential/rear drive damage.

## FILLING GAS TANK

### ⚠ WARNING

Always fill the gas tank in a well-ventilated area. Never add fuel to the gas tank near any open flames or with the engine running. DO NOT SMOKE while filling the gas tank.

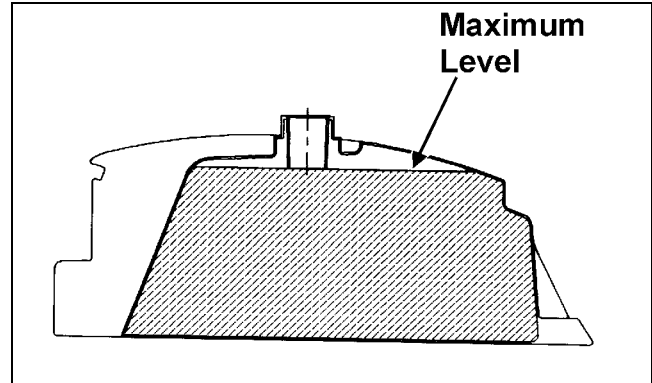

ATV0049B

Since gasoline expands as its temperature rises, the gas tank must be filled to its specified capacity only. Expansion room must be maintained in the tank particularly if the tank is filled with cold gasoline and then moved to a warm area.

### ⚠ WARNING

Do not overflow gasoline when filling the gas tank. A fire hazard could materialize. Always allow the engine to cool before filling the gas tank.

Tighten the gas tank cap securely after filling the tank.

### ⚠ WARNING

Do not over-fill the gas tank.

## Genuine Parts

When replacement of parts is necessary, use only genuine Arctic Cat parts. They are precision-made to ensure high quality and correct fit. Refer to the appropriate Illustrated Parts Manual for the correct part number, quantity, and description.

## Preparation For Storage

### CAUTION

Prior to storing the vehicle, it must be properly serviced to prevent rusting and component deterioration.

1. Clean the seat cushion (cover and base) with a damp cloth and allow it to dry.

2. Clean the vehicle thoroughly by washing dirt, oil, grass, and other foreign matter from the entire vehicle. Allow it to dry thoroughly. DO NOT get water into any part of the engine or air intake.
3. Either drain the gas tank or add Fuel Stabilizer to the gas in the gas tank. Remove the air filter housing cover and air filter. Start the engine and allow it to idle. Using Arctic Cat Engine Storage Preserver, rapidly inject the preserver into the air filter opening for a period of 10 to 20 seconds; then stop the engine. Install the air filter and housing cover.

**CAUTION**

**If the interior of the air filter housing is dirty, clean the area before starting the engine.**

4. Plug the exhaust hole in the exhaust system with a clean cloth.
5. Apply light oil to the plungers of the shock absorbers.
6. Tighten all nuts, bolts, cap screws, and screws. Make sure rivets holding components together are tight. Replace all loose rivets. Care must be taken that all calibrated nuts, cap screws, and bolts are tightened to specifications.
7. Fill the cooling system to the bottom of the stand pipe in the radiator neck with properly mixed coolant.
8. Disconnect the battery cables; then remove the battery, clean the battery posts and cables, and store in a clean, dry area.
9. Store the vehicle indoors in a level position.

**CAUTION**

**Avoid storing outside in direct sunlight and avoid using a plastic cover as moisture will collect on the vehicle causing rusting.**

---

---

## Preparation After Storage

---

Taking the vehicle out of storage and correctly preparing it will assure many miles and hours of trouble-free riding.

1. Clean the vehicle thoroughly.
2. Clean the engine. Remove the cloth from the exhaust system.
3. Check all control wires and cables for signs of wear or fraying. Replace if necessary.
4. Change the engine/transmission oil and filter.
5. Check the coolant level and add properly mixed coolant as necessary.
6. Charge the battery; then install. Connect the battery cables.

**CAUTION**

**The ignition switch must be in the OFF position prior to installing the battery or damage may occur to the ignition system.**

**CAUTION**

**Connect the positive battery cable first; then the negative.**

7. Check the entire brake systems (fluid level, pads, etc.), all controls, headlights, taillight, brakelight, and headlight aim; adjust or replace as necessary.
8. Tighten all nuts, bolts, cap screws, and screws making sure all calibrated nuts, cap screws, and bolts are tightened to specifications.
9. Check tire pressure. Inflate to recommended pressure as necessary.
10. Make sure the steering moves freely and does not bind.
11. Check the spark plug(s). Clean or replace as necessary.



# SECTION 2 - PERIODIC MAINTENANCE/TUNE-UP

---

---

## TABLE OF CONTENTS

---

---

Periodic Maintenance Chart.....	2-2
Periodic Maintenance.....	2-3
Lubrication Points.....	2-3
Air Filter.....	2-3
Valve/Tappet Clearance (H1).....	2-4
Valve/Tappet Clearance (H2).....	2-4
Testing Engine Compression.....	2-6
Spark Plug(s).....	2-6
Muffler/Spark Arrester.....	2-7
Engine/Transmission Oil - Filter.....	2-7
Front Differential - Rear Drive Lubricant.....	2-8
Driveshaft/Coupling.....	2-9
Nuts/Bolts/Cap Screws.....	2-9
Headlight/Taillight-Brakelight.....	2-9
Shift Lever.....	2-10
Hydraulic Brake System.....	2-10
Parking Brake.....	2-12
Burnishing Brake Pads.....	2-15
Checking/Replacing V-Belt.....	2-15
Troubleshooting Brake System.....	2-17

## Periodic Maintenance Chart

A = Adjust    I = Inspect  
 C = Clean    L = Lubricate  
 R = Replace    T = Tighten

Item	Initial Service After Break-In (First Month or 100 Mile)	Every Day	Every Month or Every 100 Miles	Every 3 Months or Every 300 Miles	Every 6 Months or Every 500 Miles	Every Year or Every 1500 Miles	As Needed
Battery	I		I				C
Fuses				I			R
Air Filter/Drain Tube	I	I	C*				R
Valve/Tappet Clearance	I				I		A
Engine Compression						I	
Spark Plug(s)	I			I	I		R (4000 Mi or 18 Mo)
Muffler/Spark Arrester					C		R
Gas Hoses	I	I					R (2 Yrs)
Throttle Cable Ends/Accelerator Pedal Pivot	I	I			C-L		A-R
Engine-Transmission Oil Level		I					A
Engine-Transmission Oil/Filter	R			R*/R**/R***			R
Oil Strainer	I				I***		C
Front Differential - Rear Drive Lubricant	I		I				R (4 Yrs)
Tires/Air Pressure	I	I					R
Steering Components	I	I		I			R
V-Belt	I				I		R
Suspension (Ball joint boots, drive axle boots front and rear, tie rods, differential and rear drive bellows)	I	I					R
Nuts/Bolts/Cap Screws	T		T				A
Ignition Timing						I	
Headlight/Taillight-Brakelight	I	I					R
Switches	I	I					R
Shift Lever					I		A-L
Gauges/Indicators	I	I					R
Frame/Welds	I		I		I		
Electrical Connections					I		C
Complete Brake System (Hydraulic & Parking)	I	I					
Brake Pads	I			I*			R
Brake Fluid	I			I			R (2 Yrs)
Brake Hoses	I			I			R (4 Yrs)
Coolant/Cooling System	I		I				R (2 Yrs)
Wheel Lug Nuts	T			T			

\* Service/Inspect more frequently when operating in adverse conditions.

\*\* When using an API certified SM 5W-50 oil.

\*\*\* When using Arctic Cat ACX All Weather synthetic oil, oil change and strainer inspection interval can be increased to every 1,000 miles or every year.

## Periodic Maintenance

This section has been organized into sub-sections which show common maintenance procedures for the Arctic Cat ROV.

■NOTE: Arctic Cat recommends the use of new gaskets, lock nuts, and seals and lubricating all internal components when servicing the engine/transmission.

■NOTE: Some photographs and illustrations used in this section are used for clarity purposes only and are not designed to depict actual conditions.

■NOTE: Critical torque specifications are located in Section 1.

### SPECIAL TOOLS

A number of special tools must be available to the technician when performing service procedures in this section. Refer to the current Special Tools Catalog for the appropriate tool description.

Description	p/n
Compression Tester Kit	0444-213
Oil Filter Wrench	0644-389
Timing Light	0644-296
Valve Clearance Adjuster	0444-255

■NOTE: Special tools are available from the Arctic Cat Service Parts Department.

## Lubrication Points

It is advisable to lubricate certain components periodically to ensure free movement. Apply light oil to the components using the following list as reference.

- A. Accelerator Pedal Pivot/Cable Ends
- B. Brake Pedal Pivot
- C. Parking Brake Cable Ends
- D. Shift Cable

## Air Filter

Use the following procedure to remove the filter and inspect and/or clean it.

## CLEANING AND INSPECTING FILTER

### CAUTION

Failure to inspect the air filter frequently if the vehicle is used in dusty, wet, or muddy conditions can damage the engine.

1. Remove the seats; then remove the center console.
2. Unsnap the four fasteners securing the air cleaner housing cover and remove the cover.
3. Remove the air filter frame (A); then remove the foam filter element (B).

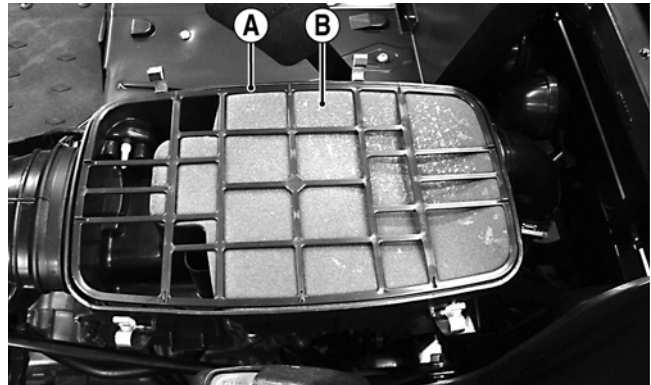

PR576A

4. Fill a wash pan larger than the filter with a non-flammable cleaning solvent; then dip the filter in the solvent and wash it.

■NOTE: Foam Filter Cleaner and Foam Filter Oil are available from Arctic Cat.

5. Dry the filter.
6. Put the filter in a plastic bag; then pour in air filter oil and work the filter. Reattach the filter to the filter screen.

■NOTE: Carefully squeeze excessive oil from the filter element. Do not twist foam to remove oil.

### CAUTION

A torn air filter can cause damage to the vehicle engine. Dirt and dust may get inside the engine if the element is torn. Carefully examine the element for tears before and after cleaning it. Replace the element with a new one if it is torn.

7. Clean any dirt or debris from inside the air cleaner. Be sure no dirt enters the throttle body.
8. Place the foam filter in the air filter housing; then position the filter frame on top.
9. Install the air filter housing cover and secure with the retaining clips; then install the center console and seats making sure the seats lock securely.

## CHECKING AND CLEANING DRAINS

1. Inspect one-way drains beneath the main housing for debris and for proper sealing.
2. Replace any one-way drain that is cracked or shows any signs of hardening or deterioration.

### CAUTION

The one-way drain to the left is the clean air section of the filter housing. Any leak of this drain will allow dirt into the engine intake causing severe engine damage.

3. Wipe any accumulation of oil or gas from the filter housing and one-way drains.

## Valve/Tappet Clearance (H1)

To check and adjust valve/tappet clearance, use the following procedure.

■NOTE: The engine must be cold for this procedure.

■NOTE: The seats, center console, spark plug, and air filter housing must be removed for this procedure.

1. Remove the spark plug and timing inspection plug; then remove the tappet covers (for more detailed information, see Section 3 - Servicing Top-Side Components).
2. Rotate the crankshaft to the TDC position on the compression stroke.

■NOTE: At this point, the rocker arms and adjuster screws must not have pressure on them.

### Feeler Gauge Procedure

Using a feeler gauge, check each valve/tappet clearance. If clearance is not within specifications, loosen the jam nut and rotate the tappet adjuster screw until the clearance is within specifications. Tighten each jam nut securely after completing the adjustment.

### CAUTION

The feeler gauge must be positioned at the same angle as the valve and valve adjuster for an accurate measurement of clearance. Failure to measure the valve clearance accurately could cause valve component damage.

#### VALVE/TAPPET CLEARANCE

Intake	0.1016 mm (0.004 in.)
Exhaust	0.1524 mm (0.006 in.)

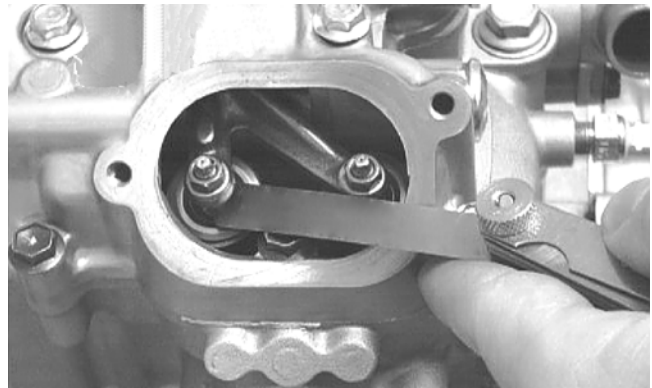

CC007D

### Valve Adjuster Procedure

- A. Place the Valve Clearance Adjuster onto the jam nut securing the tappet adjuster screw; then rotate the valve adjuster dial clockwise until the end is seated in the tappet adjuster screw.
- B. While holding the valve adjuster dial in place, use the valve adjuster handle and loosen the jam nut; then rotate the tappet adjuster screw clockwise until friction is felt.
- C. Align the valve adjuster handle with one of the marks on the valve adjuster dial.
- D. While holding the valve adjuster handle in place, rotate the valve adjuster dial counterclockwise until proper valve/tappet clearance is attained.

■NOTE: Refer to the appropriate specifications in Feeler Gauge Procedure sub-section for the proper valve/tappet clearance.

■NOTE: Rotating the valve adjuster dial counterclockwise will open the valve/tappet clearance by 0.05 mm (0.002 in.) per mark.

- E. While holding the adjuster dial at the proper clearance setting, tighten the jam nut securely with the valve adjuster handle.
3. Install the spark plug; then install the timing inspection plug.
  4. Place the two tappet covers with O-rings into position. Tighten the cap screws securely.

## Valve/Tappet Clearance (H2)

To check and adjust valve/tappet clearance, use the following procedure.

■NOTE: The engine must be cold for this procedure.

■NOTE: The seats, center console, spark plugs, and air filter housing must be removed for this procedure.

1. Remove the spark plugs and timing inspection plug; then remove the tappet covers (for more detailed information, see Section 3 - Servicing Top-Side Components).

■ **NOTE:** Remove the crankshaft end cap and install the special cap screw (left-hand threads) to rotate the engine.

2. Rotate the crankshaft to the TDC position on the compression stroke of the front cylinder. The stamped “F” must be visible.



GZ063

■ **NOTE:** At this point, the rocker arms and adjuster screws must not have pressure on them.

### Feeler Gauge Procedure

- A. Using a feeler gauge, check each valve/tappet clearance. If clearance is not within specifications, loosen the jam nut and rotate the tappet adjuster screw until the clearance is within specifications. Tighten each jam nut securely after completing the adjustment.

#### CAUTION

The feeler gauge must be positioned at the same angle as the valve and valve adjuster for an accurate measurement of clearance. Failure to measure the valve clearance accurately could cause valve component damage.

#### VALVE/TAPPET CLEARANCE

Intake	0.1016 mm (0.004 in.)
Exhaust	0.1524 mm (0.006 in.)

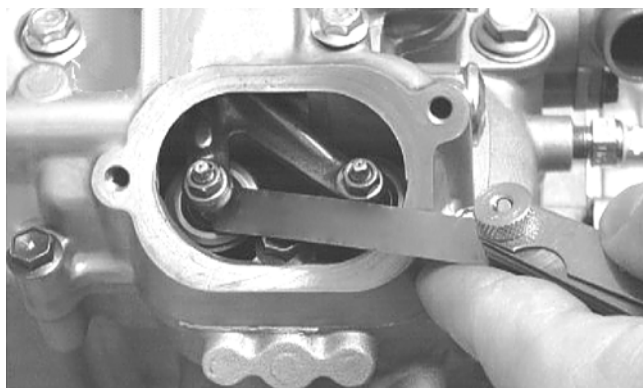

CC007DC

- B. Rotate the engine 270° to the TDC position of the rear cylinder; then repeat step A. The stamped “R” must be visible.



GZ059

### Valve Adjuster Procedure

2

- A. Place the Valve Clearance Adjuster onto the jam nut securing the tappet adjuster screw; then rotate the valve adjuster dial clockwise until the end is seated in the tappet adjuster screw.
- B. While holding the valve adjuster dial in place, use the valve adjuster handle and loosen the jam nut; then rotate the tappet adjuster screw clockwise until friction is felt.
- C. Align the valve adjuster handle with one of the marks on the valve adjuster dial.
- D. While holding the valve adjuster handle in place, rotate the valve adjuster dial counterclockwise until proper valve/tappet clearance is attained.

■ **NOTE:** Refer to the appropriate specifications in Feeler Gauge Procedure sub-section for the proper valve/tappet clearance.

■ **NOTE:** Rotating the valve adjuster dial counterclockwise will open the valve/tappet clearance by 0.05 mm (0.002 in.) per mark.

- E. While holding the adjuster dial at the proper clearance setting, tighten the jam nut securely with the valve adjuster handle.
  - F. Rotate the engine 270° to the TDC position of the rear cylinder; then repeat steps A-D for the rear cylinder.
3. Install the spark plugs and timing inspection plug; then remove the cap screw and install the crankcase end cap.
  4. Place the two tappet covers into position making sure the proper cap screws are with the proper cover. Tighten the cap screws securely.

## Testing Engine Compression

To test engine compression, use the following procedure.

■NOTE: The engine should be warm (operating temperature) and the battery fully charged for an accurate compression test. On the XT/XTX, throttle must be in the wide-open throttle (WOT) position. In the event the engine can not be run, cold values are included.

■NOTE: The seats and center console must be removed for this procedure.

1. Remove the high tension lead from the spark plug.
2. Using compressed air, blow any debris from around the spark plug.

### ⚠ WARNING

Always wear safety glasses when using compressed air.

3. Remove the spark plug(s); then attach the high tension lead(s) to the plug(s) and ground the plug(s) on the cylinder head(s) well away from the spark plug hole(s).
4. Attach the Compression Tester Kit.
5. While holding the throttle in the full-open position, crank the engine over with the electric starter until the gauge stops climbing (five to 10 compression strokes).

Model	PSI Hot (WOT)	PSI Cold (WOT)
550	120-140	80-120
700	125-145	100-140
950 (Front)	125-145	80-120
950 (Rear)	165-185	150-190

6. If compression is abnormally low, inspect the following items.
  - A. Starter cranks engine over.
  - B. Gauge is functioning properly.
  - C. Throttle in the full-open position.
  - D. Valve/tappet clearance correct.
  - E. Valve bent or burned.
  - F. Valve seat burned.
  - G. Piston rings worn or bent.
  - H. Cylinder worn or scored.
  - I. Head gasket blown.

■NOTE: To service top-side components, see Section 3.

7. Pour approximately 30 ml (1 fl oz) of oil into the spark plug holes(s), reattach the gauge, and retest compression.
8. If compression is now evident, service the piston rings (see Section 3).

## Spark Plug(s)

A light brown insulator indicates that the plug is correct. A white or dark insulator indicates that the engine may need to be serviced. To maintain a hot, strong spark, keep the plug free of carbon.

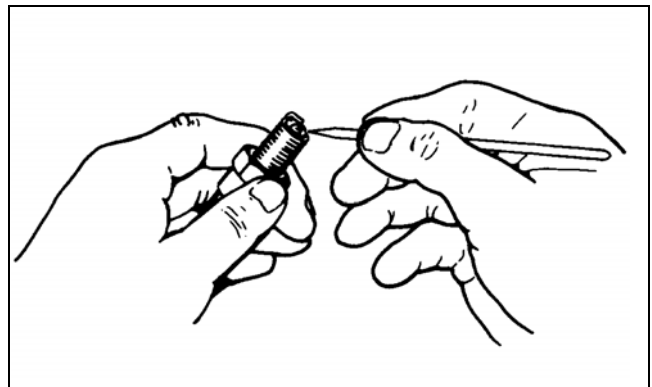

ATV-0051

### CAUTION

Before removing the spark plug, be sure to clean the area around the spark plug. Dirt could enter engine when removing or installing the spark plug.

Adjust the gap to 0.7-0.8 mm (0.028-0.032 in.).

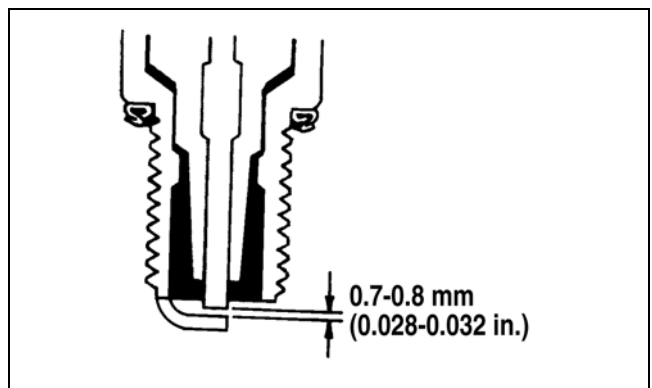

ATV0052C

When installing the spark plug, be sure to tighten it securely. A new spark plug should be tightened 1/2 turn once the washer contacts the cylinder head. A used spark plug should be tightened 1/8-1/4 turn once the washer contacts the cylinder head.

---

---

## Muffler/Spark Arrester

---

Clean the spark arrester using the following procedure.

**⚠ WARNING**

**Wait until the muffler cools to avoid burns.**

1. Remove the cap screws securing the spark arrester screen assembly to the muffler; then loosen and remove the spark arrester. Account for a gasket.

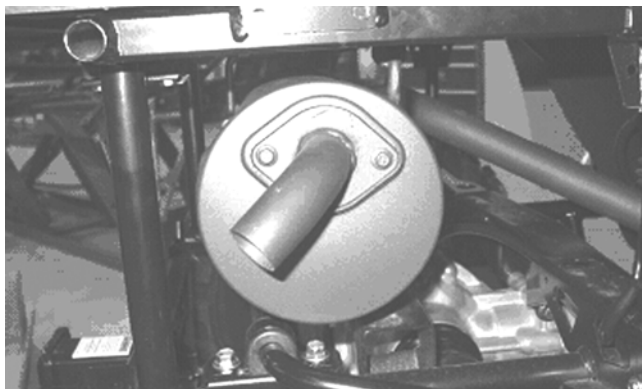

PR498

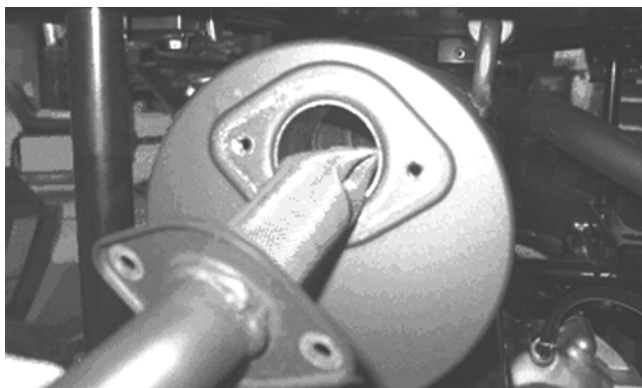

PR499

2. Using a suitable brush, clean the carbon deposits from the screen taking care not to damage the screen.

**NOTE: If the screen or gasket is damaged in any way, it must be replaced.**

3. Install the spark arrester assembly and gasket and secure with the cap screws. Tighten the cap screws to 48 in.-lb.

---

---

## Engine/Transmission Oil - Filter

---

### OIL - FILTER

Change the engine oil and oil filter at the scheduled intervals. The engine should always be warm when the oil is changed so the oil will drain easily and completely.

**NOTE: To change oil and filter, the seats and center console must be removed.**

1. Park the vehicle on level ground.
2. Remove the oil level stick/filler plug.

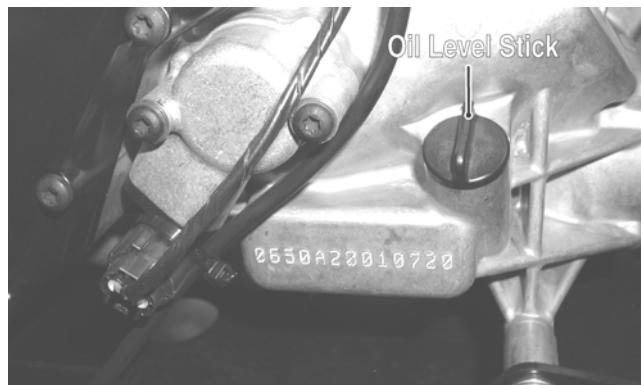

PR053B

**2**

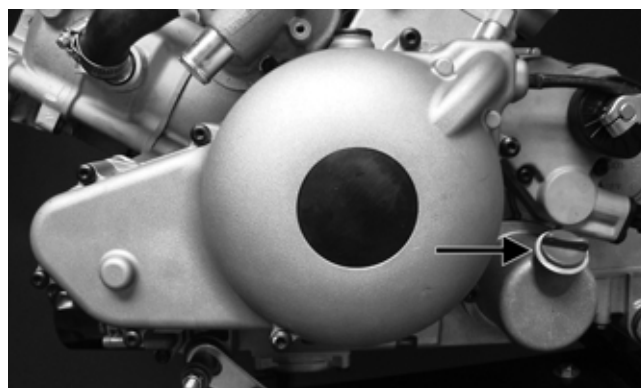

GZ415A

3. Remove the drain plug from the bottom of the engine and drain the oil into a drain pan.

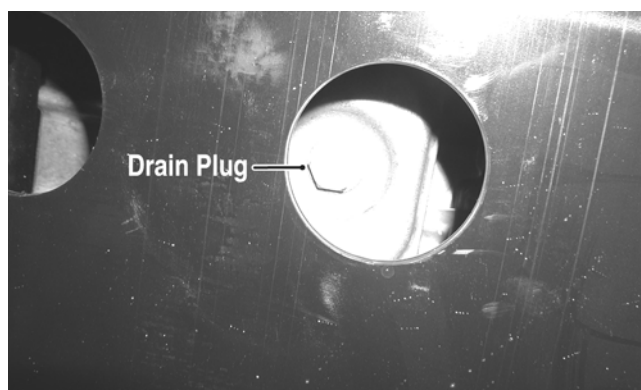

PR078A

4. Using the Oil Filter Wrench and a ratchet handle (or a socket or box-end wrench), remove the old oil filter.

**NOTE: Clean up any excess oil after removing the filter.**

5. Apply oil to a new filter O-ring and check to make sure it is positioned correctly; then install the new oil filter. Tighten securely.

6. Install the engine drain plug and tighten to 16 ft.-lb. Pour the specified amount of the recommended oil in the filler hole. Install the oil level stick/filler plug.

**CAUTION**

Any oil used in place of the recommended oil could cause serious engine damage. Do not use oils which contain graphite or molybdenum additives. These oils can adversely affect clutch operation. Also, not recommended are racing, vegetable, non-detergent, and castor-based oils.

7. Start the engine (while the vehicle is outside on level ground) and allow it to idle for a few minutes.
  8. Turn the engine off and wait approximately one minute.
  9. Unscrew the oil level stick and wipe it with a clean cloth.
  10. Install the oil level stick and thread into the engine case.
- NOTE: The oil level stick should be threaded into the case for checking the oil level.
11. Remove the oil level stick; the oil level must be within the operating range but not exceeding the upper mark.



GZ461A

**CAUTION**

Do not over-fill the engine with oil. Always make sure that the oil level is not above the upper mark.

12. Inspect the area around the drain plug and oil filter for leaks.

## Front Differential - Rear Drive Lubricant

To check lubricant, use the following procedure.

1. Remove the fill plug; the lubricant level should be one inch below the plug threads.

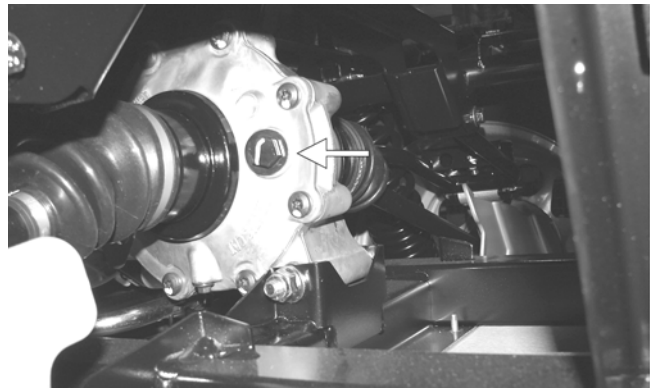

PR530A

2. If low, add SAE approved 80W-90 hypoid gear lube as necessary.

To change the lubricant, use the following procedure.

1. Place the vehicle on level ground.
2. Remove each fill plug.
3. Drain the lubricant into a drain pan by removing in turn the drain plug from each.

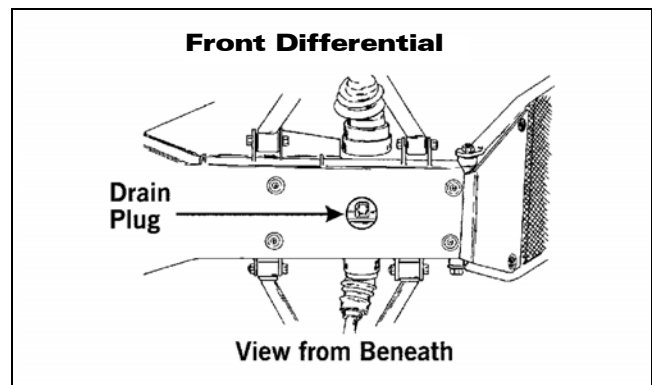

ATV0082A

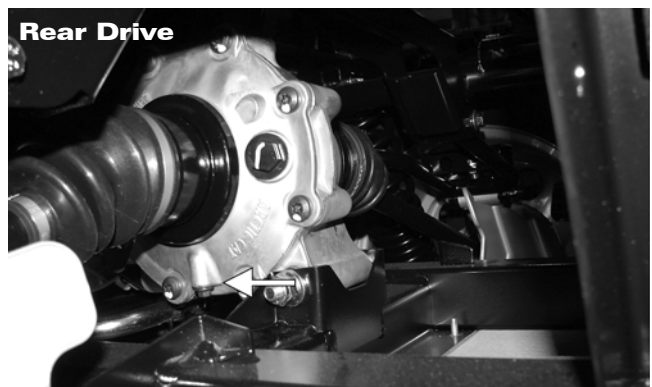

PR530B

4. After all the lubricant has been drained, install the drain plugs and tighten to 45 in.-lb.
5. Pour the appropriate amount of recommended lubricant into the fill hole.
6. Install the fill plug.

■NOTE: If the lubricant is contaminated with water, inspect the drain plug, fill plug, and/or bladder.



## Driveshaft/Coupling

The following drive system components should be inspected periodically to ensure proper operation.

- A. Spline lateral movement (slop).
- B. Coupling cracked, damaged, or worn.
- C. Universal joints worn or missing bearings.

## Nuts/Bolts/Cap Screws

Tighten all nuts, bolts, and cap screws. Make sure rivets holding components together are tight. Replace all loose rivets. Care must be taken that all calibrated nuts, bolts, and cap screws are tightened to specifications.

## Headlight/Taillight-Brakelight

### HEADLIGHT

■NOTE: The bulb portion of the headlight is fragile. HANDLE WITH CARE. When replacing the headlight bulb, do not touch the glass portion of the bulb. If the glass is touched, it must be cleaned with a dry cloth before installing. Skin oil residue on the bulb will shorten the life of the bulb.

### ⚠ WARNING

Do not attempt to remove the bulb when it is hot. Severe burns may result.

To replace the headlight bulb, use the following procedure.

1. Remove the wiring harness connector from the back of the headlight.
2. Grasp the bulb socket, turn it counterclockwise and remove, and pull the bulb straight out of the socket.
3. Install the new bulb into the socket and rotate it completely clockwise in the housing.
4. Install the wiring harness connector.

### TAILLIGHT-BRAKELIGHT

To replace the taillight-brakelight bulb, use the following procedure.

1. Remove the two machine screws and remove the light assembly.

2. Rotate the bulb socket counterclockwise to remove it from the light assembly; then pull straight out on the bulb. Push the new bulb straight into the socket.
3. Install the bulb and socket into the light assembly and turn clockwise to lock in place.
4. Install the taillight-brakelight assembly on the canopy support.

### CHECKING/ADJUSTING HEADLIGHT AIM

The headlights can be adjusted vertically. The geometric center of the HIGH beam light zone is to be used for vertical aiming.

1. Position the vehicle on a level floor so the headlights are approximately 6.1 m (20 ft) from an aiming surface (wall or similar aiming surface).

■NOTE: There should be an average operating load on the vehicle when adjusting the headlight aim.

2. Measure the distance from the floor to the mid-point of each headlight.
3. Using the measurements obtained in step 2, make horizontal marks on the aiming surface.
4. Make vertical marks which intersect the horizontal marks on the aiming surface directly in front of the headlights.
5. Switch on the lights. Make sure the HIGH beam is on. DO NOT USE LOW BEAM.
6. Observe each headlight beam aim. Proper aim is when the most intense beam is centered on the vertical mark 5 cm (2 in.) below the horizontal mark on the aiming surface.

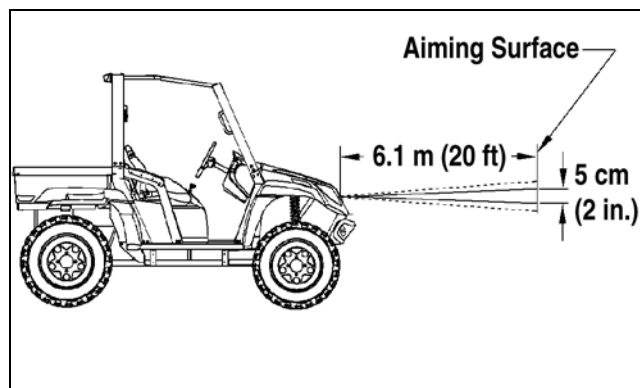

0740-647

7. Using the adjuster knob, adjust each headlight until correct aim is obtained.

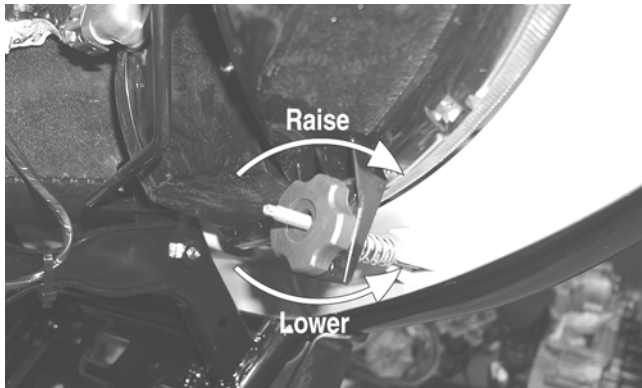

CD714A

## Shift Lever

### CHECKING SHIFT CABLE

Set the parking brake and turn the ignition switch on; then with the shift lever in the neutral position, look for the (N) indication on the LCD. Shift into high range and look for the (H) indication, low range for the (L) indication, and reverse for the (R) indication. Shift the transmission into neutral and turn the ignition switch off.

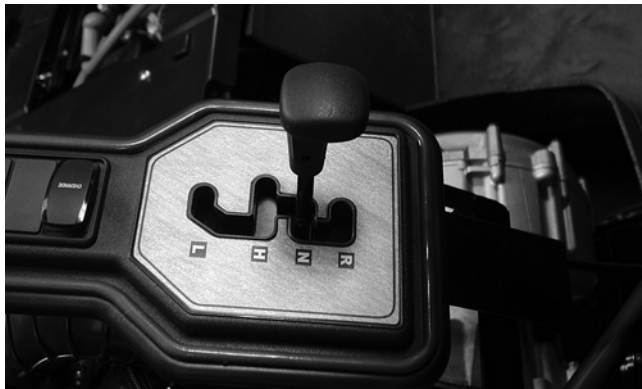

PR571

### ADJUSTING SHIFT CABLE

To adjust the shift cable, use the following procedure.

1. Set the parking brake; then remove the seats and center console.
2. Make sure the shift lever is in neutral; then remove the E-clip securing the cable end to the shaft arm.



PR567A

3. Loosen nuts (A) and (B) and adjust the cable housing to align the shift cable end to the shift arm stud (C).

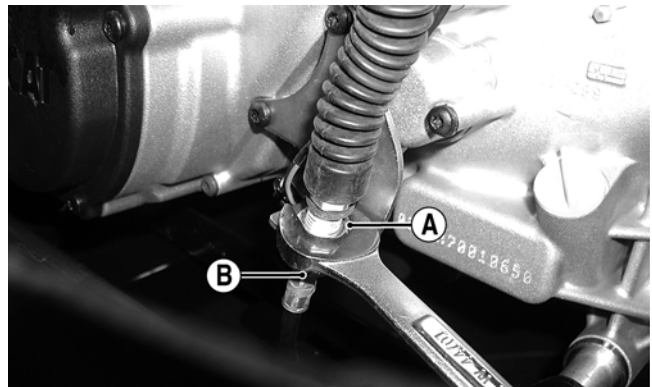

PR568A

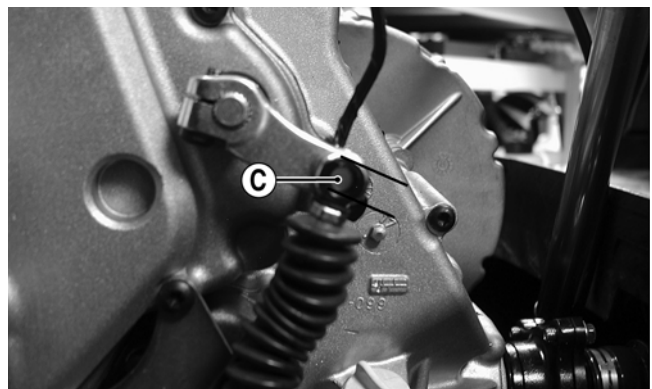

PR572A

4. Install the E-clip; then tighten the nuts (A) and (B) securely.
5. Check each gear shift position for proper gear selection and make sure the proper icon illuminates on the LCD; then install the center console and seats.

## Hydraulic Brake System

■NOTE: The XT/XTX models are equipped with driveline hydraulic and cable-actuated calipers incorporating a bleed screw for the hydraulic brake and a cable adjuster for parking brake adjustment. The XTZ model is equipped with hydraulic brakes at all four wheels and a cable only actuator driveline parking brake.

## CHECKING/BLEEDING

The hydraulic brake system has been filled and bled at the factory. To check and/or bleed a hydraulic brake system, use the following procedure.

1. With the master cylinder in a level position, check the fluid level in the reservoir. If the level in the reservoir is not above the MIN, add DOT 4 brake fluid.



PR095

2. Depress the brake pedal several times to check for a firm brake. If the brake is not firm, the system must be bled.
3. To bleed the brake system, use the following procedure.
  - A. Remove the cover and fill the reservoir with DOT 4 Brake Fluid.
  - B. Install and secure the cover; then slowly depress the brake pedal several times.
  - C. Remove the protective cap, install one end of a clear hose onto one FRONT bleeder screw, and direct the other end into a container; then while holding slight pressure on the brake pedal, open the bleeder screw and watch for air bubbles. Close the bleeder screw before releasing the brake pedal. Repeat this procedure until no air bubbles are present.



AF637D

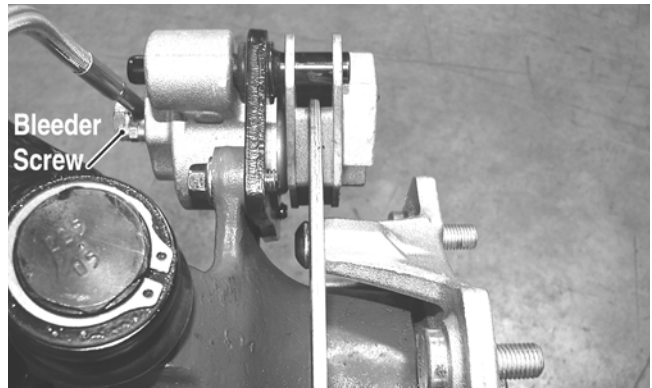

PR377C

■NOTE: During the bleeding procedure, watch the reservoir very closely to make sure there is always a sufficient amount of brake fluid. When the level falls below MIN, refill the reservoir before the bleeding procedure is continued. Failure to maintain a sufficient amount of fluid in the reservoir will result in air in the system.

2

- D. At this point, perform steps B and C on the other FRONT bleeder screw; then move to the REAR bleeder screw(s) and follow the same procedure.
  - E. Repeat steps B and C until the brake pedal is firm.
4. Carefully check the entire hydraulic brake system that all hose connections are tight, the bleed screws are tight, the protective caps are installed, and no leakage is present.

**CAUTION**

This hydraulic brake system is designed to use DOT 4 brake fluid only. If brake fluid must be added, care must be taken as brake fluid is very corrosive to painted surfaces.

## INSPECTING HOSES

Carefully inspect the hydraulic brake hoses for cracks or other damage. If found, the brake hoses must be replaced.

## CHECKING/REPLACING PADS

The clearance between the brake pads and brake discs is adjusted automatically as the brake pads wear. The only maintenance that is required is replacement of the brake pads when they show excessive wear. Check the thickness of each of the brake pads as follows.

1. Remove a front wheel.
2. Measure the thickness of each brake pad.

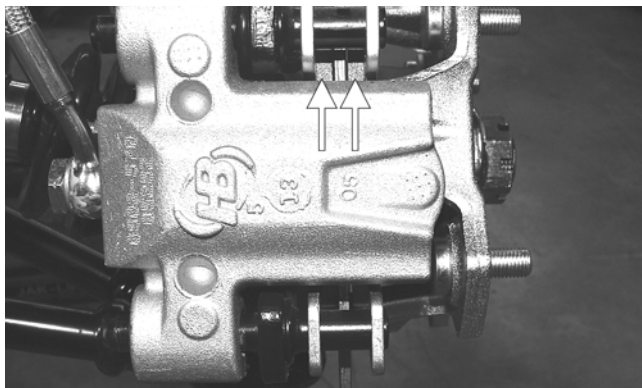

PR376A

3. If thickness of either brake pad is less than 1.0 mm (0.039 in.), the brake pads must be replaced.

■ **NOTE:** The brake pads should be replaced as a set.

4. To replace the brake pads, use the following procedure.
  - A. Remove the wheel.
  - B. Remove the cap screws securing the caliper holder to the knuckle; then remove the pads from the caliper.



PR237

- C. Install the new brake pads.
- D. Secure the caliper holder to the knuckle with new "patch-lock" cap screws. Tighten to 20 ft-lb.

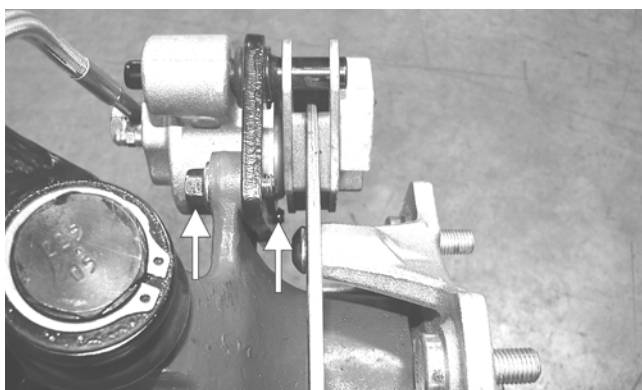

PR377B

- E. Install the wheel. Tighten to 80 ft-lb (aluminum wheels) or 45 ft-lb (steel wheels).

5. Burnish the brake pads (see Burnishing Brake Pads in this section).

## BRAKE DISC

Using a micrometer, measure the thickness of the brake disc in the contact surface. If thickness is 0.125-in. or less, the disc must be replaced. To replace the brake disc, see Section 6 – Hub.

---

---

## Parking Brake

---

### CHECKING

Although the parking brake has been adjusted at the factory, the brake should be checked for proper operation. The brake must be maintained to be fully functional.

1. With the engine off, transmission in neutral, and the parking brake set, attempt to move the vehicle.
2. If the rear wheels are locked, it is adjusted properly.
3. If the rear wheels are not locked, it must be adjusted (set up).

### ADJUSTING

1. Remove the seats and center console.
2. With the parking brake lever released, loosen the adjuster nut (A); then turn the jam nut (B) clockwise several turns.

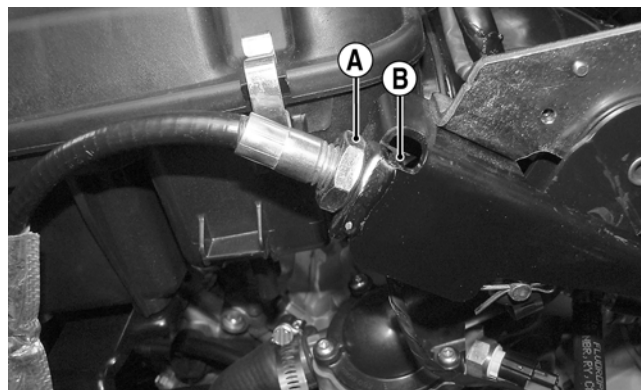

PR682A

3. Turn the adjuster nut clockwise to remove cable slack.
4. Check for proper adjustment by applying the parking brake and attempting to move the vehicle. The vehicle should not move.
5. If adjustment is correct, tighten the adjuster nut securely. On the XTZ if further adjustment is required, repeat steps 2-4. On the XT/XTX, proceed to step 6.
6. Release parking brake lever to fully-off position; then loosen the nut (B) and turn nut (A) clockwise several turns.