

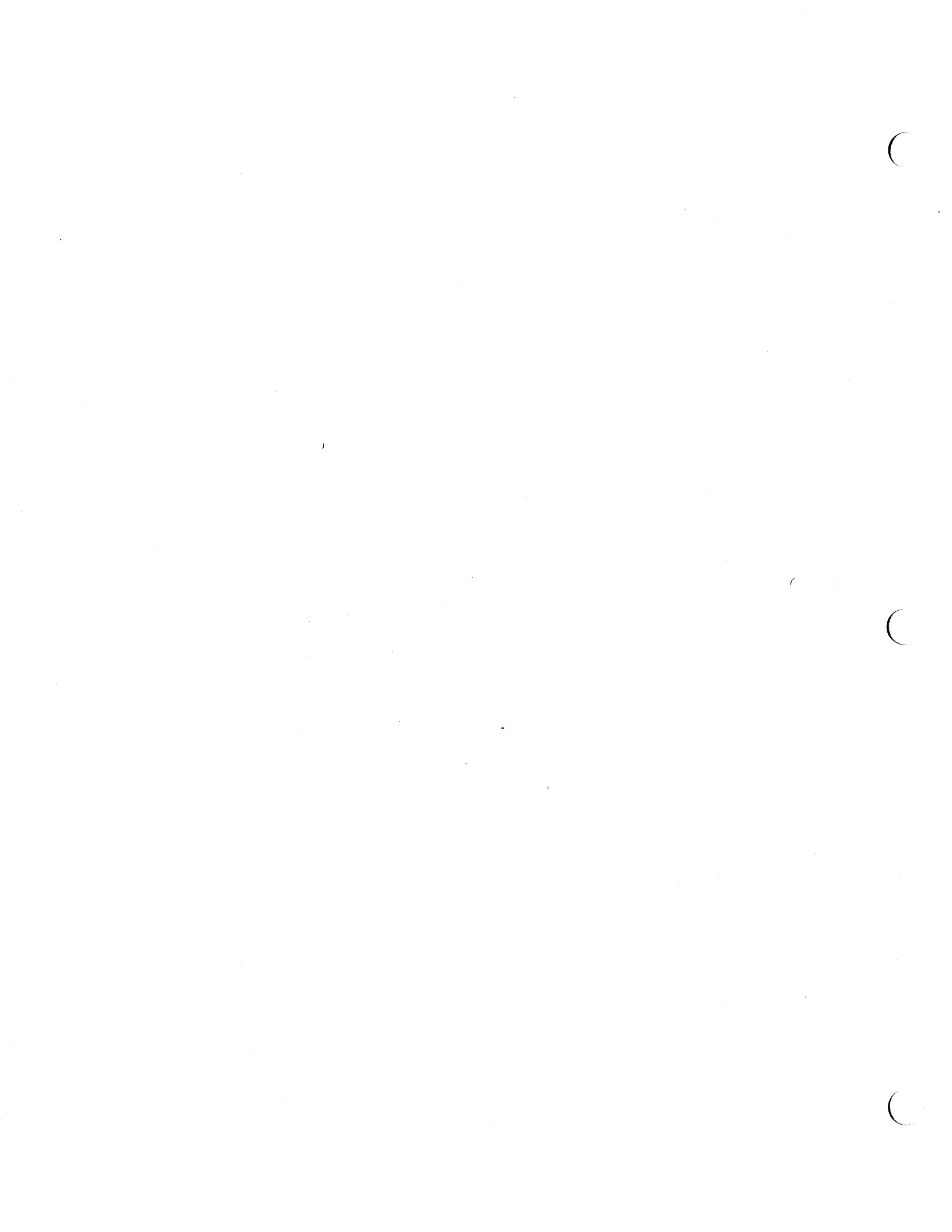

PARTS CATALOG

H-4 & HD-4 CRAWLER TRACTORS



FOREWORD

The parts in this catalog are listed in alphabetical order and are located at the front of this catalog.

Except for some common hardware all parts are identified with an item number. Common hardware not identified such as bolts, nuts, cotter pins and lubrication fittings, are listed in the text under the part which they attach or fit into. Note particularly that the quantity of hardware listed is always the quantity required for one part.

Common attaching hardware listed under a part is not included in the assembly or included with the part unless specified. Example: (Incl. Bolt, Lockwasher and Nut).

"Assembly or Packaged Parts" indicates if an individual part is one of many in a large assembly or one of several kinds in a package.

All numbers are listed in the second last section of this catalog showing the quantity and description of the various parts that make up the assembly or package.

The last section of this catalog contains a part number index to indicate on which page or pages a part number appears.

All illustrations will be found to **Follow** the text of each group or section of which it is a part.

For any additional copies of this catalog there will be a supplementing service charge of three dollars. Refer any requests to your Branch House or office under which you operate.

HOW TO ORDER PARTS

Order all parts for this machine from your local ALLIS-CHALMERS Dealer.

When ordering parts for this unit, supply the following information:

1. The tractor and engine serial numbers.
2. Fork Lift serial number. The Fork Lift serial number is located on the R.H. side of frame over final drive housing near brake pedals.

The Mast Serial number is located on inside of the bottom channel iron of mast assembly.

3. State the common name of the part you wish to order, or a description of the part and its location on the unit, or bring in old part.

4. Always print your name and post office address, where parts are to be shipped; also specify whether material is to be shipped by freight, express or parcel post.

5. When ordering parts always determine right hand and left hand from a position in the operators seat facing the direction of forward travel.

IMPORTANT

Unless claims for shortages or errors are made immediately upon receipt of goods, they will not be considered.

When broken goods are received, a full description of the damage should be made by the carrier agent on the freight bill. If this description is insisted upon full damage can always be collected from the transportation company.

No responsibility is assumed for delay or damage to merchandise while in transit. Our responsibility ceases upon

delivery of shipment to the transportation company, from whom a receipt is received showing that shipment was in good condition when delivered to them; therefore claims (if any) should be filed with the transportation company and not with Allis-Chalmers Manufacturing Company.

The right is reserved to change the construction or material of any parts where it seems desirable to do so, without incurring the obligation of installing such changes on units already delivered.

INDEX

ADAPTOR PLATE	
Diesel	24
Gasoline	24
AIR CLEANER	
Diesel	62
Gasoline	62
AIR CLEANER HOSES	
Diesel	62
Gasoline	66
AIR FILTER INDICATOR	64
AIR HEATER, diesel	62
ASSEMBLIES & PACKAGE PARTS	190 thru 194
AXLE, final drive	120
BATTERY GROUP	
Diesel	70
Gasoline	70
BRAKE BAND & ARM	130
BRAKE LINKAGE	128
BRAKE PEDALS & LINKAGE	126
CARBURETOR, gasoline	56
CARBURETOR COMPONENTS, gasoline	58
CLUTCH SHIFTER	128
CONNECTING ROD	
Diesel	12
Gasoline	12
CONSOLE SHELL & SHUTTLE CLUTCH CONTROL	92, 93
CONTROL VALVES	162, 163
End Sections	164
Main Relief	164
Section, valve (A).	166
Section, valve (D).	166
Section, valve (E).	168
Section, valve (F).	170
Section, valve (J).	172
CRANKSHAFT	
Diesel	10
Gasoline	10
CYLINDER BLOCK	
Diesel	6, 8
Gasoline	6, 8
CYLINDER HEAD	
Diesel	20
Gasoline	18
DECELERATOR	96
DISTRIBUTOR, gasoline	44
DIVERTER	
Hydraulic Group, I64 & I600 Backhoe	174
Valve, I64 & I600 Backhoe	174
DRAWBAR	176
DRIVE SHAFT & RING GEAR	118
ETHER STARTING SYSTEM, diesel	64

EXHAUST MANIFOLD	
Diesel	24
Gasoline	22
FAN DRIVE SHAFT	30
FINAL DRIVE HOUSING	116
FLYWHEEL	
Diesel	24
Gasoline	24
FRONT PLATE	
Diesel	28
Gasoline	26
FUEL FILTER, diesel	46
FUEL INJECTION PUMP, diesel	46
FUEL PUMP, gasoline	38
FUEL TANK	
Diesel	84
Gasoline	84
FUEL TANK FILTER	
Diesel	86
Gasoline	86
GEAR COVER	
Diesel	28
Gasoline	26
GENERATOR	68
GENERATOR ASSEMBLY	66
GOVERNOR, gasoline	40
HAND BRAKE CONTROLS, steering clutch	122
HAND PRIMER PUMP ASSEMBLY, diesel	54
HEAD LAMPS	184
HITCH, 3 Point	
Lift Arm Hydraulic Ram	176
Lift Bars	178
Lift Links & Beaming Tube	178
Lift Shaft & Supports	180
HOLLOW CLUTCH SHAFT	100
HOOD, SHELL, GRILLE, MUFFLER & EXTENSION	82
HOOK, pull	180
HOUR METER	90
HYDRAULIC HOUSING & GEAR	
Diesel	30
Gasoline	30
HYDRAULIC OIL FILTER, front	160
HYDRAULIC PUMP	156
HYDRAULIC SYSTEM	154, 155
IDLER GEAR ASSEMBLY, diesel	26
IDLER PULLEY	
Diesel	60
Gasoline	60
IDLER SHAFT & GEARS, standard	102
IDLER SHAFT & GEARS, w/winch	102
IGNITION, gasoline	42
INDEX, numerical	195

INJECTION LINES, diesel	48
INJECTION PUMP COMPONENTS, diesel	
Housing & Drive	50, 51
Transfer Pump, Head & Rotor.	53
INSTRUMENT PANEL	88
INTAKE MANIFOLD	
Diesel.	22
Gasoline	22
INTERMEDIATE SHAFT & GEAR	104
MAIN FRAME & ENGINE SUPPORT	140
NOZZLE HOLDER, diesel	48
NOZZLE HOLDER ASSEMBLY, diesel.	54
OIL FILTER	
Diesel.	38
Gasoline	38
OIL PAN	
Diesel.	36
Gasoline	36
OIL PUMP	
Diesel.	36
Gasoline	36
OPERATORS SEAT, standard & Backhoe	144
PAN, rear bottom.	182
PAN GUARD, rock & bottom	182
PINION SHAFT	114
PISTON	
Diesel.	12
Gasoline	12
PLATFORM.	142, 144
POWER SHUTTLE CLUTCH	100
PUMP & MANIFOLD, rear.	158
RADIATOR, HOSES & SUPPORT.	78, 80
RADIO.	184
RESERVOIR FILTER.	160
RESERVOIR HYDRAULIC OIL	158
RESERVOIR OIL STRAINER & MAGNET.	160
SHUTTLE CLUTCH & OIL COOLER LINES	150, 152
SHUTTLE CLUTCH & SUMP LINES	146, 148
SHUTTLE CLUTCH INTERNAL LINES.	148
SHUTTLE CLUTCH VALVE	152
SUPPORT ROLLER.	130
SPROCKET, final drive.	120
STARTING MOTOR	
Diesel.	74, 76
Gasoline	72, 74
STEERING CLUTCH	124
TACH-HOUR METER & DRIVE.	90
THERMOSTAT & HOUSING	
Diesel.	32
Gasoline	32
TORQUE CONVERTER	86
TORQUE HOUSING	94

TURBINE INPUT SHAFT	98
TRACK	136, 138
TRACK IDLER	132
TRACK RELEASE.	138
TRANSMISSION	
Gear Shift	114
Housing	110
Mainshaft.	110
Pinion Shaft.	112
TRUCK FRAME.	134
TRUCK WHEEL.	134
UNIVERSAL CARRIER W/TIE BRACES	
Dozer, H-4	186
Dozer, 493 & 4100	186
Loader, H-4	186
VALVE OPERATING MECHANISM	
Diesel.	16
Gasoline	14
WATER PUMP	
Diesel.	34
Gasoline	34
WEIGHT BRACKET GROUP	188
WEIGHT CARRIER GROUP, w/universal carrier.	188
WINCH DRIVE, front shaft & housing	106, 108
WINCH DRIVE SHAFT, rear	108
WINCH SHIFTER	104

CYLINDER BLOCK
Gasoline & Diesel

ITEM	NUMBER	QTY.	DESCRIPTION
1	4023061-7	1	BLOCK ASSY., cylinder (Incl. Items 2, 3, 5, 9, 13, 14, 15, 18, 24, 25, 26, 27 thru 30 & hardware below)
		2	0919134-7 PLUG, pipe, 1/8
		1	908944 PLUG, pipe, 1/2
		1	0919840-9 PLUG, pipe, 1/4
		1	0918850-9 PLUG, pipe, 1/4
		1	0912415-7 COCK, drain, 1/4
		2	0917547-2 PIN, dowel, 3/8 x 3/4
		1	0915399-0 ELBOW, 90°, 1/8
2	4025025-0	1	BEARING, camshaft, front (standard)
	4025259-5	1	BEARING, camshaft, front (.010" u/s)
3	4362338	1	PLUG, oil level gauge hole
4	4021445	1	SWITCH, oil pressure
5	4507673-4	1	INSERT, oil pressure relief valve
6	4507374	1	PISTON, relief valve
7	4500231	1	SPRING, relief valve
8	4022129	1	SCREW, regulating valve
9	4255107-7	2	PLUG, pipe
10	4023099	4	SLEEVE, cylinder
11	4020537	*	SHIM, cylinder sleeve (.005" thick)
	4020538	*	SHIM, cylinder sleeve (.010" thick)
	4020539	*	SHIM, cylinder sleeve (.015" thick)
	4020540	*	SHIM, cylinder sleeve (.020" thick)
			* NOTE: Use as required when remachining cylinder block.
		4	O-RING, cylinder sleeve (lower)
12	4023827-1	4	O-RING, cylinder sleeve (lower)
13	4255492-3	2	PLUG, pipe
14	4254452	1	PLUG, expansion (for diesel only)
15	4025238-9	2	BEARING, camshaft, center & rear (standard)
	4025258-7	2	BEARING, camshaft, center & rear (.010" u/s)
16	4021612	1	GAUGE, oil level
17	4021616	1	ADAPTOR ASSY., oil level gauge
18	4025392	1	PLUG, pipe 1/2, 1/16 hole
19	4025019	1	GASKET, cover plate
20	4026383	1	PLATE, fuel pump hole cover
		2	921332 CAPSCREW, 5/16NC x 3/4, Gr. 5
		2	917365 WASHER, lock, 5/16
			NOTE: These parts, Items 19, 20 & hardware, not required when tractor is equipped with fuel pump.
21	4021711-9	1	PLUG, oil filter (replaces 4385253)
22	4021498-3	1	ELBOW, oil filler (replaces 4020512)
		2	920415 CAPSCREW, 3/8NC x 1-1/4
		2	916965 WASHER, lock 5/16
		2	0922464-3 WASHER, plain
23	4025021	1	GASKET, elbow
24	4020382-0	1	CAP, main bearing, rear (see Note)
25	4020381-2	1	CAP, main bearing, intermediate (see Note)

(Continued)

CYLINDER BLOCK
Gasoline & Diesel

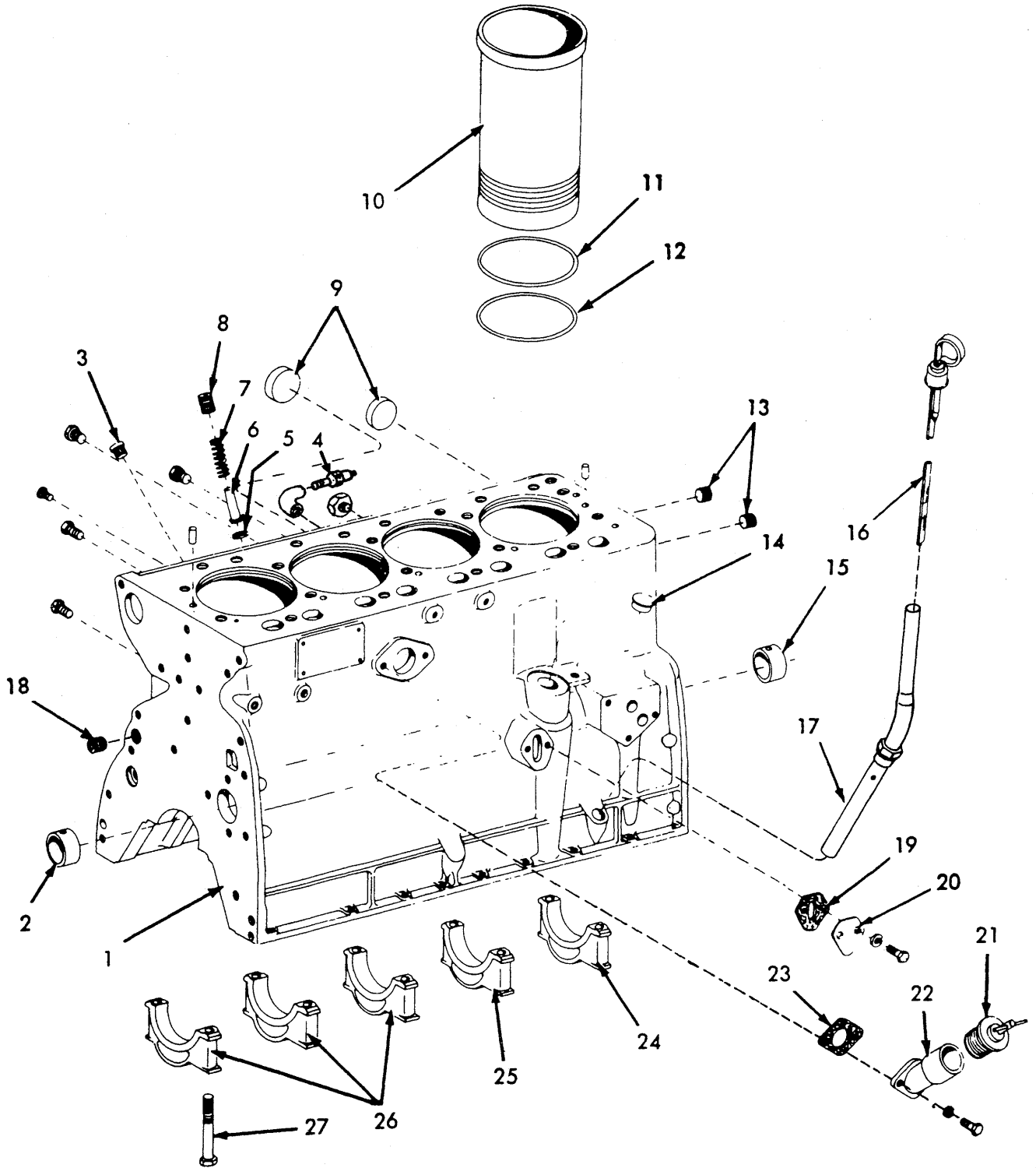

CYLINDER BLOCK
Gasoline & Diesel
(Continued)

ITEM	NUMBER	QTY.	DESCRIPTION
26	4020380-4	3	CAP, main bearing, front, intermediate & center (see Note)
27	4020135-2	10	CAPSCREW, main bearing cap

NOTE: Replacement bearing caps are semi-finished and must be line-bored after installing.

ASSEMBLIES & PACKAGES

--	4390237	1	PLATE, name (not shown)
		1	4 904516 PIN, drive
--	4022492	1	ENGINE ASSY., replacement, diesel (Discontinued)
--	4022305	1	ENGINE ASSY., replacement, gasoline (Discontinued)

NOTE: Replacement engines do not include fans, generator, starting motor, air cleaner, clutch, carburetor, carburetor linkage, engine supports, crankshaft pulley, or flywheel.

--	4021634	--	SET, gasket (incl. Items 19 & 23)
--	4021635	--	KIT, gasket (incl. Items 19 & 23)
--	4022318	--	KIT, sleeve (gasoline) (incl. Items 10 & 12)
--	4022979	--	KIT, sleeve (diesel) (incl. Items 10 & 12)

104-1

CYLINDER BLOCK
Gasoline & Diesel
(Continued)

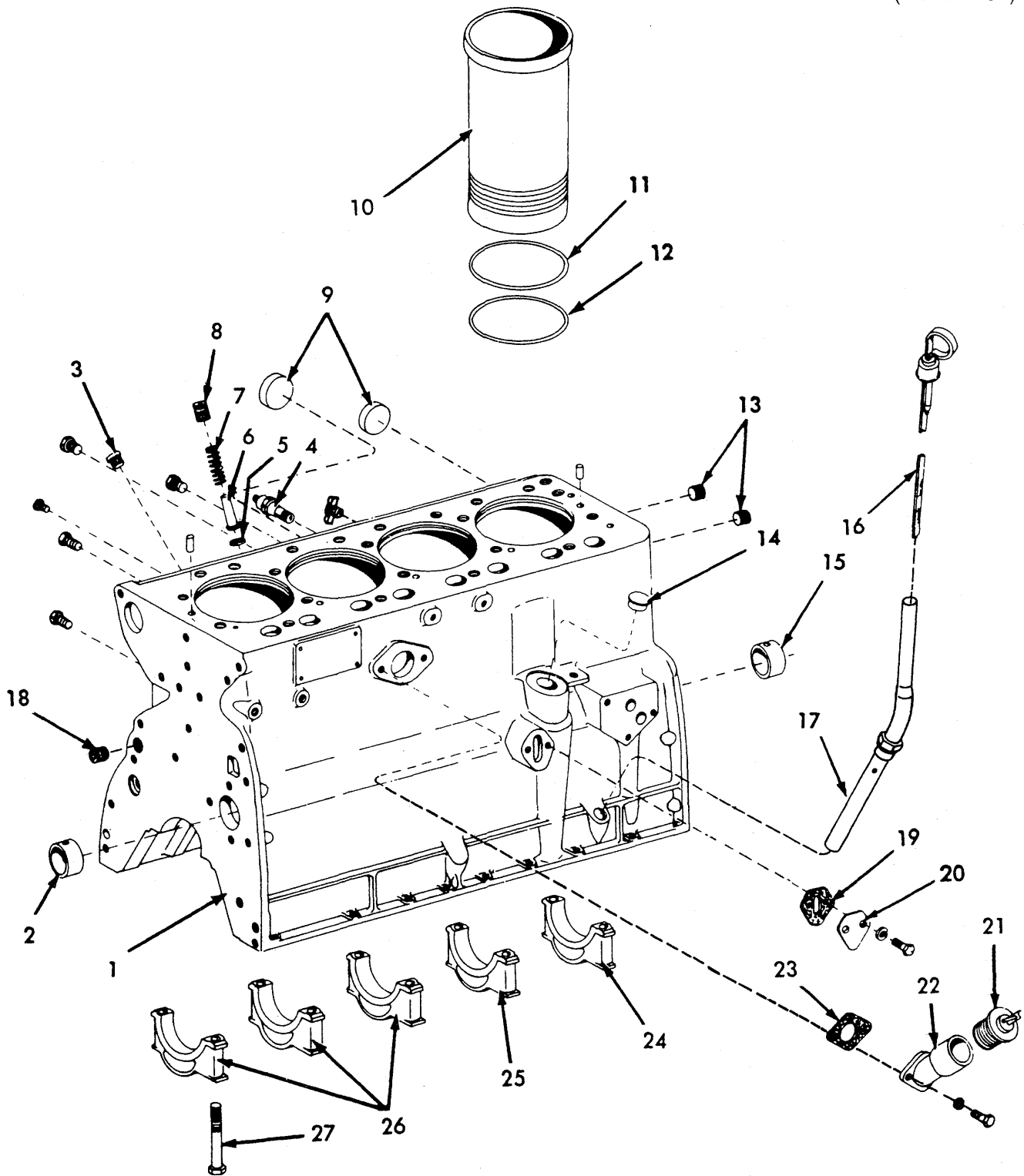

CRANKSHAFT
Gasoline & Diesel

ITEM	NUMBER	QTY.	DESCRIPTION
1	4021525	1	CAPSCREW
2	4020149	1	WASHER, capscrew
3	4020246	1	PULLEY
		1	905845 KEY, woodruff, 1/4 x 7/8
4	4022228	1	GEAR, crankshaft
		1	905845 KEY, woodruff, 1/4 x 7/8
5	4022285	5	CRANKSHAFT
6	4022083	3	BEARING, front, intermediate (upper) (standard)
	4022094-9	3	BEARING, front, intermediate (upper) (.002") (replaces 4020450)
	4022095	3	BEARING, front, intermediate (upper) (.010")
	4022096	3	BEARING, front, intermediate (upper) (.020")
	4022098-0	3	BEARING, front, intermediate (upper) (.040") (replaces 4020454)
7	4022087	1	BEARING, center (upper) (standard)
	4022114-5	1	BEARING, center (upper) (.002") (replaces 4020470)
	4022115	1	BEARING, center (upper) (.010")
	4022116	1	BEARING, center (upper) (.020")
	4022118-6	1	BEARING, center (upper) (.040") (replaces 4020474)
8	4022085	1	BEARING, rear (upper) (standard)
	4022104-6	1	BEARING, rear (upper) (.002") (replaces 4020460)
	4022105	1	BEARING, rear (upper) (.010")
	4022106	1	BEARING, rear (upper) (.020")
	4022108-7	1	BEARING, rear (upper) (.040") (replaces 4020464)
9	4022086	1	BEARING, rear (lower) (standard)
	4022109-5	1	BEARING, rear (lower) (.002") (replaces 4020465)
	4022110	1	BEARING, rear (lower) (.010")
	4022111	1	BEARING, rear (lower) (.020")
	4022113-7	1	BEARING, rear (lower) (.040") (replaces 4020469)
10	4022088	1	BEARING, center (lower) (standard)
	4022119-4	1	BEARING, center (lower) (.002") (replaces 4020475)
	4022120	1	BEARING, center (lower) (.010")
	4022121	1	BEARING, center (lower) (.020")
	4022123-6	1	BEARING, center (lower) (.040") (replaces 4020479)
11	4022084	3	BEARING, front, intermediate (lower) (standard)
	4022099-8	3	BEARING, front, intermediate (lower) (.002") (replaces 4020455)
	4022100	3	BEARING, front, intermediate (lower) (.010")
	4022101	3	BEARING, front, intermediate (lower) (.020")
	4022103-8	3	BEARING, front, intermediate (lower) (.040") (replaces 4020459)

104-2

CRANKSHAFT
Gasoline & Diesel

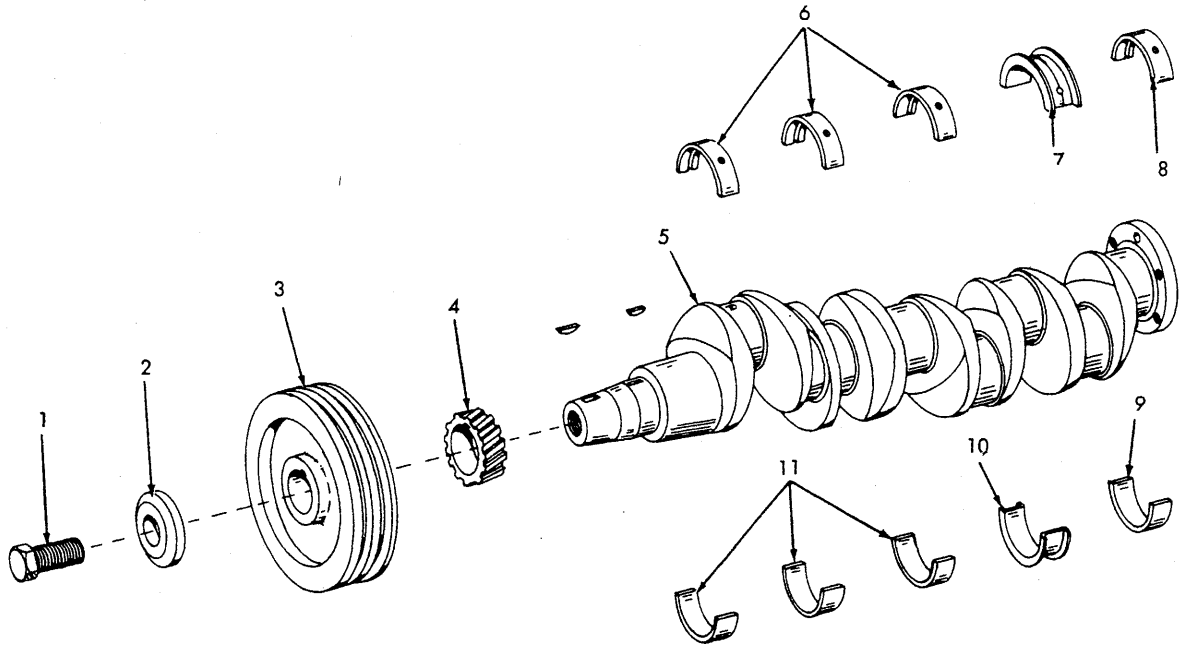

PISTON & CONNECTING ROD
 Gasoline

ITEM	NUMBER	QTY.	DESCRIPTION
1	4020142	8	CAPSCREW, connecting rod
2	4020145	8	WASHER, flat, capscrew
3	4022233-8	4	ROD ASSY., connecting (incl. Items 1, 2, & 7)
4	4022082-8	8	BEARING, connecting rod (standard)
	4022089-9	8	BEARING, connecting rod (.002")
	4022090-7	8	BEARING, connecting rod (.010")
	4022091-5	8	BEARING, connecting rod (.020")
	4022092-3	8	BEARING, connecting rod (.030")
	4022093-1	8	BEARING, connecting rod (.040")
5	4020739	4	PIN, piston
6	4253059	8	RETAINER, piston pin
7	4020049	4	BUSHING, connecting rod
8	4021796	4	RING SET, piston (incl. 1 Top Ring, 2 Rings 2nd & 3rd & 1 three piece Oil Control Ring)
9	4022313	4	PISTON

ASSEMBLIES & PACKAGES

--	4022318	--	KIT, sleeve (incl. Items 5, 6, 8, & 9)
----	---------	----	--

PISTON & CONNECTING ROD
 Diesel

ITEM	NUMBER	QTY.	DESCRIPTION
1	4020142	8	CAPSCREW, connecting rod
2	4020145	8	WASHER, flat, capscrew
3	4022233	4	ROD ASSY., connecting (incl. Items 1, 2, & 7)
4	4022082	8	BEARING, connecting rod (standard)
	4022089-9	8	BEARING, connecting rod (.002")
	4022090-7	8	BEARING, connecting rod (.010")
	4022091-5	8	BEARING, connecting rod (.020")
	4022092-3	8	BEARING, connecting rod (.030")
	4022093-1	8	BEARING, connecting rod (.040")
5	4020739	4	PIN, piston
6	4253059	8	RETAINER, piston pin
7	4020049	4	BUSHING, connecting rod
8	4021796	4	RING SET, piston (incl. 1 Top Ring, 2 Rings 2nd & 3rd, & 1 three piece Oil Control Ring)
9	4023926-1	4	PISTON (replaces 4022958)

ASSEMBLIES & PACKAGES

--	4022979	--	KIT, sleeve (incl. Items 5, 6, 8, & 9)
----	---------	----	--

104-3

PISTON & CONNECTING ROD
Gasoline

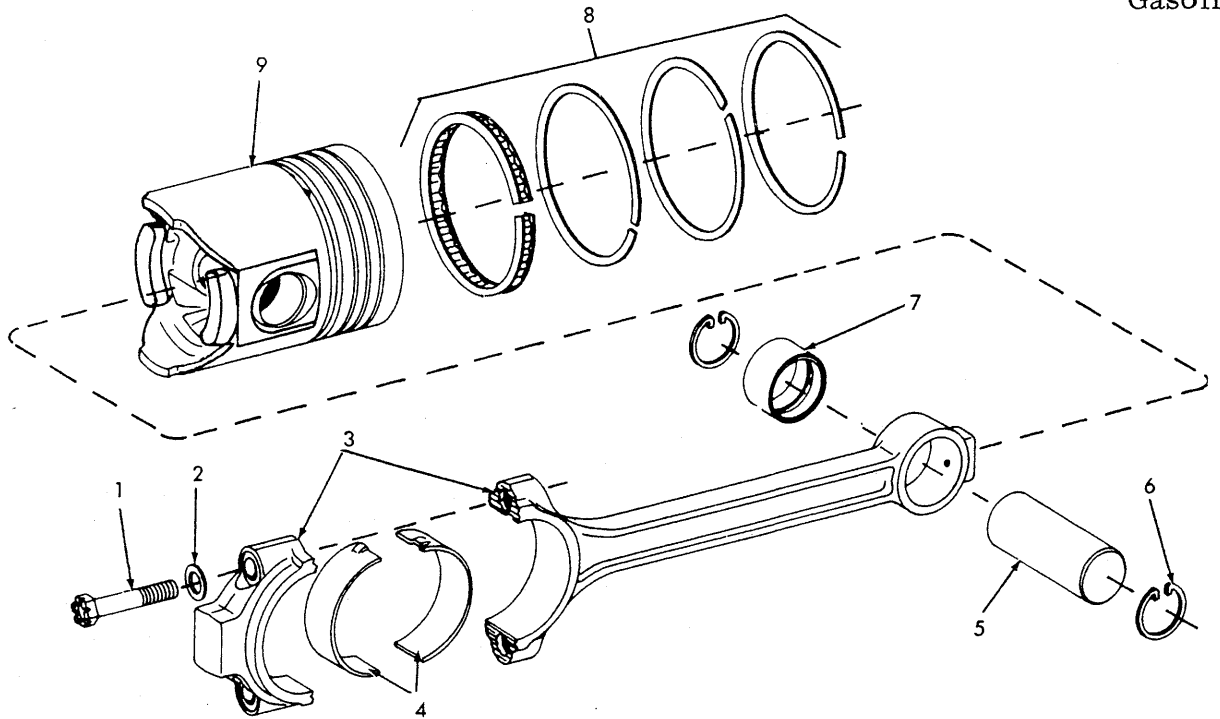

104-4

PISTON & CONNECTING ROD
Diesel

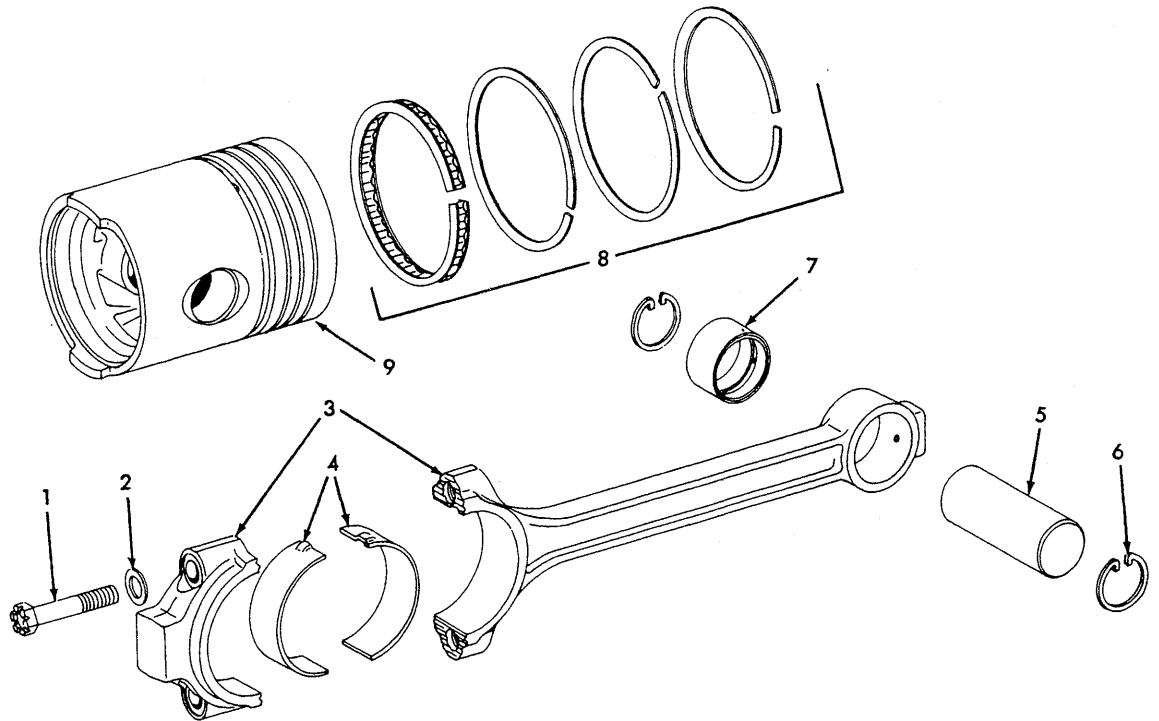

VALVE OPERATING MECHANISM
 Gasoline

ITEM	NUMBER	QTY.	DESCRIPTION
1	4022459	1	CAMSHAFT
2	4021454	1	PLATE, thrust
3	4254864	2	BOLT, place
4	4022292-9	1	GEAR, camshaft (prior to SN2G-07615) (replaces 4022229)
	4022458	1	GEAR, camshaft (eff. w/SN2G-07615 & up)
		1	4022430 KEY
5	4022339	1	WASHER
6	0925821	1	CAPSCREW, 7/16NC x 4
7	4026699	8	LIFTER, valve
8	4020683	1	TUBE, oil feed
		2	911435 SLEEVE, 1/4
		1	913536 NUT, inverted flared, 1/4
		1	914626 CONNECTOR, male, 1/4 x 1/8
		1	911437 NUT, inverted flared, 1/4
9	4020185	8	ROD, push
10	4021453	1	SHAFT, rocker arm
		2	925719 PIN, cotter, 1/8 x 2
11	4512644	2	PLUG, shaft
12	4020359	1	TUBE, oil drain
		1	911435 SLEEVE, 1/4
		1	913536 NUT, inverted flared, 1/4
13	4513206-5	8	SCREW, adjusting
14	4025191	3	SPRING, spacer, center
15	4020307	2	BRACKET, rocker arm, intermediate
		2	921333 CAPSCREW, 5/16NC x 1
		2	917356 WASHER, lock 5/16
16	4020177	4	ARM ASSY., rocker (Off-set to left) (incl. Item 14)
17	4020176	4	ARM ASSY., rocker (Off-set to right) (incl. Item 14)
18	4020308	2	BRACKET, rocker arm (end)
19	4025193	2	SPRING, washer spacing (end)
20	4025194	4	WASHER, spacing (end)

104-6

VALVE OPERATING MECHANISM
Gasoline

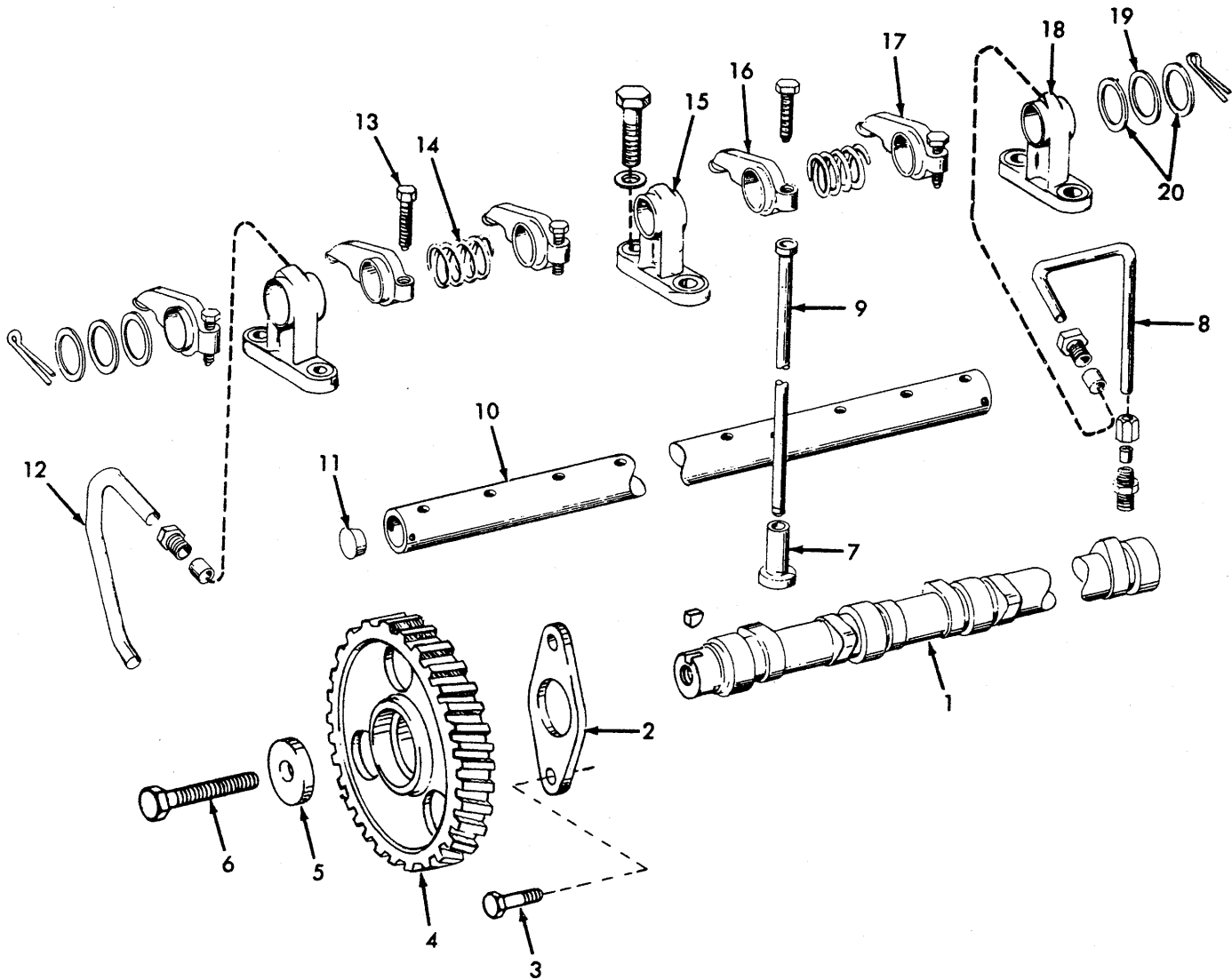

VALVE OPERATING MECHANISM
Diesel

ITEM	NUMBER	QTY.	DESCRIPTION
1	4022458	1	CAMSHAFT
2	4021454	1	PLATE, thrust
3	4254864	2	BOLT, place
4	4024459	1	GEAR, camshaft (prior to SN 2D-18297)
	4022292	1	GEAR, camshaft (eff. SN 2D-18297 & up)
		1	4022430 KEY
5	4022339	1	WASHER
6	0925821	1	CAPSCREW, 7/16 x 4
7	4026699	8	LIFTER, valve
8	4020683	1	TUBE, oil feed
		2	911435 SLEEVE, 1/4
		1	913536 NUT, inverted flared, 1/4
		1	914626 CONNECTOR, male, 1/4 x 1/8
		1	911437 NUT, inverted flared, 1/4
9	4020185	8	ROD, push
10	4021453	1	SHAFT, rocker arm
		2	925719 PIN, cotter, 1/8 x 1-3/8
11	4512644	2	PLUG, shaft, rocker arm
12	4020359	1	TUBE, oil drain
		1	913536 NUT, inverted flared, 1/4
		1	911435 SLEEVE, 1/4
13	4025193	2	WASHER, spring (end)
14	4025194	4	WASHER, spacer (end)
15	4025188	8	ARM ASSY., rocker (incl. Item 17)
16	4020143	4	BRACKET, rocker arm (end)
		1	919224 CAPSCREW, 3/8NC x 1-1/8
		1	916965 WASHER, lock, 3/8
17	4513206-5	8	SCREW, adjusting, rocker arm
18	4025191	3	SPRING, rocker arm, spacing
19	-----	4	CAPSCREW, bracket (see Cylinder Head Group)

104-5

VALVE OPERATING MECHANISM
Diesel

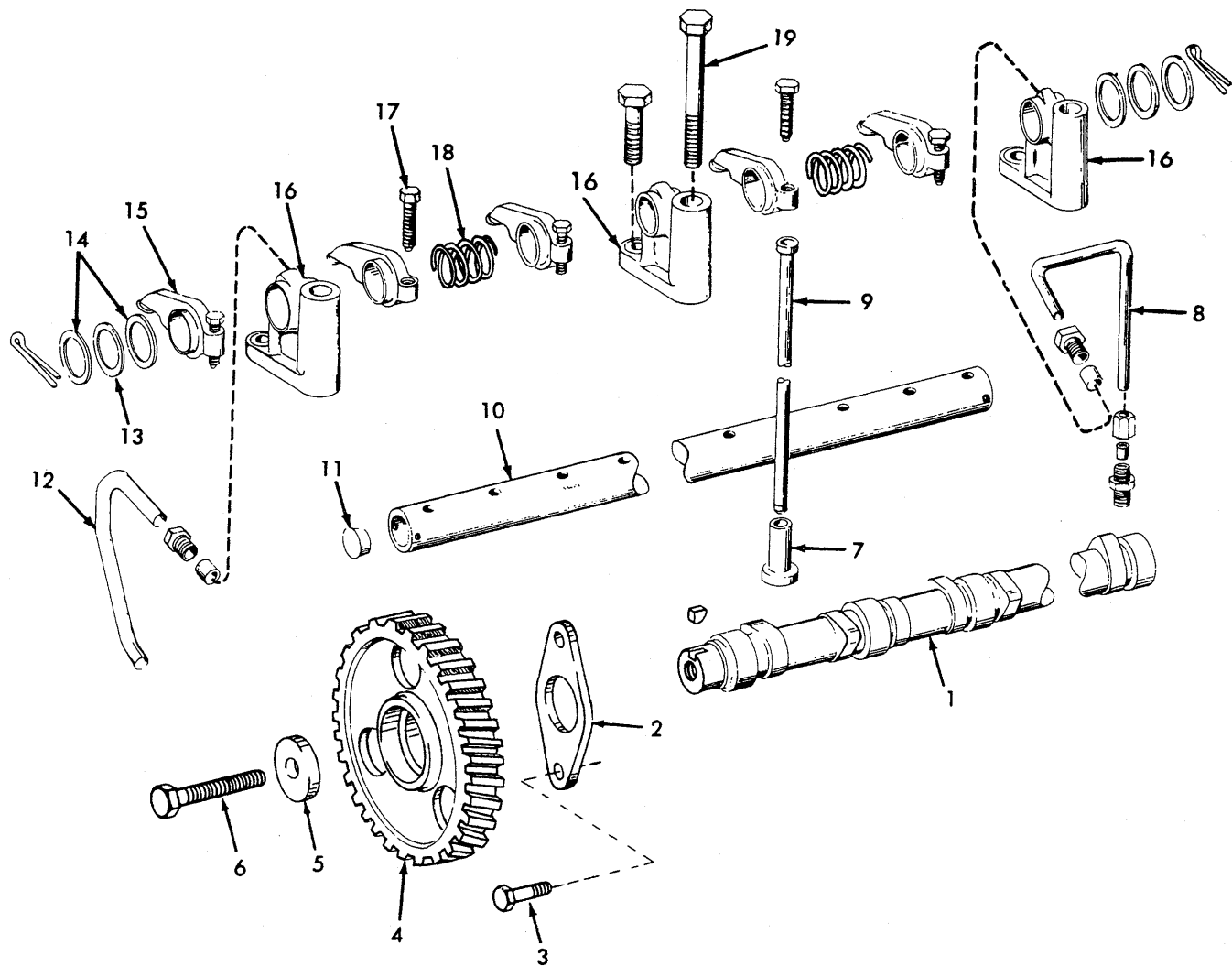

CYLINDER HEAD

Gasoline

ITEM	NUMBER	QTY.	DESCRIPTION
1	4022897-5	1	GASKET, cylinder head (prior to S/N 2G-09490)
	4021825-7	1	GASKET, cylinder head (Inc. S/N 2G-09490 & up)
2	4020080	4	VALVE, intake
3	4020082	4	VALVE, exhaust
4	4020147	*	INSERT, intake valve (1.6105" to 1.6115" O.D.) (Intake seat inserts are not original equipment - requires remachining of cylinder head)
5	4020146	4	INSERT, exhaust valve (standard)
	4020536	*	INSERT, exhaust valve (.005" o/s)
6	4022649	1	HEAD ASSY., cylinder (incl. Items 4, 5, 7, & plugs) 3 918851 PLUG, pipe, 3/4NPTF
7	4022595	8	GUIDE, intake & exhaust
8	4020156	8	SPRINGS, intake & exhaust
9	4020419	4	ROTATOR, exhaust valve
10	4020408	4	RETAINER, spring, intake valve
11	4376497	16	LOCK, half, valve spring retainer
12	4020317	1	GASKET, cylinder head cover
13	4022081	1	COVER, cylinder head
14	4153776	6	CAPSCREW, cover, cylinder head
15	4025491	6	WASHER, capscrew, cylinder head cover
16	4029256-7	17	CAPSCREW, cylinder head (replaces 4025164)
17	4025165	17	WASHER, capscrew
18	4020813	2	EYE, lifting
19	244819	1	BRACKET, tube 1 903771 CAPSCREW, 5/6NC x 7/8 1 917356 WASHER, lock, 5/16
20	4020494	1	ELBOW, trailer tube
21	4254757	2	CLAMP, elbow
22	247288	1	TUBE, breather trailer
23	4303933	1	CLIP, by-pass tube 1 903626 CAPSCREW, 5/16NC x 3/4 1 917356 WASHER, lock, 5/16 1 917372 NUT, 5/16NC
--	4306010-2	1	CLIP, trail tube (not shown)

ASSEMBLED & PACKAGES

--	4022948-6	--	KIT, gasket (incl. Items 1 & 12) (Prior to S/N 2G-09490)
	4021851-3		KIT, gasket (incl. Items 1 & 12) (incl. S/N 2G-09490 & up)

* Use as required