

INTRODUCTION

How to Use This Manual

This manual is divided into multiple sections. The first page of each section is marked with a black tab that lines up with its corresponding thumb index tab on this page and the back cover. You can quickly find the first page of each section without looking through a full table of contents. The symbols printed at the top corner of each page can also be used as a quick reference system.

Each section includes:

1. A table of contents, or an exploded view index showing:
 - Parts disassembly sequence.
 - Bolt torques and thread sizes.
 - Page references to descriptions in text.
2. Disassembly/assembly procedures and tools.
3. Inspection.
4. Testing/troubleshooting.
5. Repair.
6. Adjustments.

Safety Messages

Your safety, and the safety of others, is very important. To help you make informed decisions, we have provided safety messages, and other safety information throughout this manual. Of course, it is not practical or possible to warn you about all the hazards associated with servicing this vehicle. You must use your own good judgment.

You will find important safety information in a variety of forms including:

- **Safety Labels** — on the vehicle.
- **Safety Messages** — preceded by a safety alert symbol  and one of three signal words, DANGER, WARNING, or CAUTION. These signal words mean:

- ▲ DANGER** You WILL be KILLED or SERIOUSLY HURT if you don't follow instructions.
- ▲ WARNING** You CAN be KILLED or SERIOUSLY HURT if you don't follow instructions.
- ▲ CAUTION** You CAN be HURT if you don't follow instructions.

- **Instructions** — how to service this vehicle correctly and safely.

All information contained in this manual is based on the latest product information available at the time of printing. We reserve the right to make changes at anytime without notice. No part of this publication may be reproduced, stored in retrieval system, or transmitted, in any form by any means, electronic, mechanical, photocopying, recording, or otherwise, without the prior written permission of the publisher. This includes text, figures, and tables.

As you read this manual, you will find information that is preceded by a **NOTICE** symbol. The purpose of this message is to help prevent damage to your vehicle, other property, or the environment.

First Edition 07/2005 2,038 pages

All Rights Reserved

Specifications apply to U.S.A. and Canada

HONDA MOTOR CO., LTD.
Service Publication Office

As sections with * include SRS components;
special precautions are required when servicing.

General Info



Specifications

specs

Maintenance



*Engine Electrical



Engine



Cooling



Fuel and Emissions



Transaxle



*Steering



Suspension



Brakes
(Including ABS)



*Body



*Heating, Ventilation
and Air Conditioning



*Body Electrical

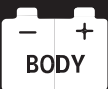

*Restraints



- DYNAMITE 2009 -

SUPPLEMENTAL RESTRAINT SYSTEM (SRS)

The Acura RSX SRS includes a driver's airbag in the steering wheel hub, a passenger's airbag in the dashboard above the glove box, seat belt tensioners in the front seat belt retractors, seat belt buckle tensioners in the front seat belt buckles, and side airbags in the front seat-backs. Information necessary to safely service the SRS is included in this Service Manual. Items marked with an asterisk (*) on the contents page include or are located near SRS components. Servicing, disassembling, or replacing these items require special precautions and tools, and should be done only by an authorized Acura dealer.

- To avoid rendering the SRS inoperative, which could lead to personal injury or death in the event of a severe frontal or side collision, all SRS service work must be performed by an authorized Acura dealer.
- Improper service procedures, including incorrect removal and installation of the SRS could lead to personal injury caused by unintentional deployment of the airbags and/or side airbags.
- Do not bump or impact the SRS unit, front impact sensors, side impact sensors whenever the ignition switch is ON (II), or for at least 3 minutes after the ignition switch is turned OFF. Otherwise, the system may fail in a collision, or the airbags may deploy.
- SRS electrical connectors are identified by yellow color coding. Related components are located in the steering column, front console, dashboard, dashboard lower panel, in the dashboard above the glove box, in the front seats, and around the floor. Do not use electrical test equipment on these circuits.



General Information

Chassis and Paint Codes	
2002 Model	1-2
Chassis and Paint Codes	
2003 Model	1-3
Chassis and Paint Codes	
2004 Model	1-4
Chassis and Paint Codes	
2005 Model	1-5
Chassis and Paint Codes	
2006 Model	1-6
Identification Number Locations	1-7
Danger/Warning/Caution Label Locations	1-8
Under-hood Emission Control Label	1-10
Lift and Support Points	1-12
Towing	1-13
Parts Marking	1-14

General Information

Chassis and Paint Codes

2002 Model

Vehicle Identification Number

JH4	DC5	3	8	*	2	C	000001
a	b	c	d	e	f	g	h

a. Manufacturer, Make and Type of Vehicle
 JH4: HONDA MOTOR CO., LTD.
 ACURA passenger vehicle

b. Line, Body and Engine Type
 DC5: ACURA RSX/K20A2, K20A3

c. Body Type and Transmission Type
 3: 2-door Hatchback/5-speed Manual
 2-door Hatchback/6-speed Manual
 4: 2-door Hatchback/5-speed Automatic

d. Vehicle Grade (Series)
 U.S. Model Canada Model
 0: Type S 0: Type S
 8: RSX 6: RSX
 8: Premium

e. Check Digit

f. Model Year
 2: 2002

g. Factory Code
 C: Saitama Factory in Japan

h. Serial Number
 U.S.: 000001—
 Canada: 800001—

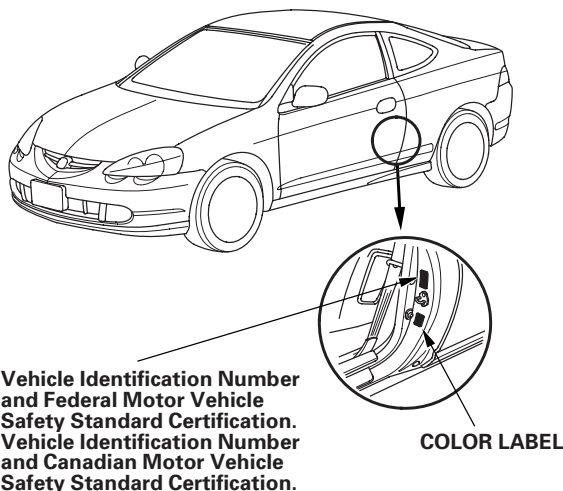

Engine Number

K20A2	-	1400001
a		b

a. Engine Type
 K20A2: 2.0 L DOHC i-VTEC Sequential Multiport Fuel-injected 200 HP engine
 K20A3: 2.0 L DOHC i-VTEC Sequential Multiport Fuel-injected 160 HP engine

b. Serial Number
 K20A2: 1400001—
 K20A3: 1100001—

Transmission Number

MRMA	-	1000001
a		b

a. Transmission Type
 MRMA: 5-speed Automatic
 W2M5: 5-speed Manual
 X2M5: 6-speed Manual

b. Serial Number

Paint Code

Code	Color	U.S.	Canada
B-507P	Arctic Blue Pearl	○	○
B-92P	Nighthawk Black Pearl	○	○
B-96P	Eternal Blue Pearl	○	
NH-578	Taffeta White	○	
NH-623M	Satin Silver Metallic	○	○
NH-636P	Brilliant White Pearl		○
R-81	Milano Red		○
R-507P	Fire Pepper Red Pearl	○	
YR-534M	Desert Silver Metallic	○	○



2003 Model

Vehicle Identification Number

JH4 DC5 3 8 * 3 C 000001

|-----|-----|-----|-----|-----|-----|-----|-----|

a b c d e f g h

a. Manufacturer, Make and Type of Vehicle
JH4: HONDA MOTOR CO., LTD.
ACURA passenger vehicle

b. Line, Body and Engine Type
DC5: ACURA RSX/K20A2, K20A3

c. Body Type and Transmission Type
3: 2-door Hatchback/5-speed Manual
2-door Hatchback/6-speed Manual
4: 2-door Hatchback/5-speed Automatic

d. Vehicle Grade (Series)
U.S. Model Canada Model
0: Type S 0: Type S
8: RSX 8: RSX
8: Premium

e. Check Digit

f. Model Year
3: 2003

g. Factory Code
C: Saitama Factory in Japan
S: Suzuka Factory in Japan

h. Serial Number
U.S.: 000001—
Canada: 800001—

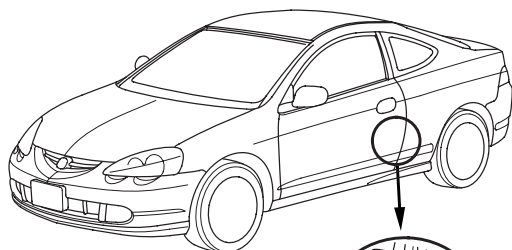

Vehicle Identification Number and Federal Motor Vehicle Safety Standard Certification.
Vehicle Identification Number and Canadian Motor Vehicle Safety Standard Certification.

COLOR LABEL

Engine Number

K20A2 - 2400001

|-----|-----|

a b

a. Engine Type
K20A2: 2.0 L DOHC i-VTEC Sequential Multiport Fuel-injected 200 HP engine
K20A3: 2.0 L DOHC i-VTEC Sequential Multiport Fuel-injected 160 HP engine

b. Serial Number
K20A2: Saitama Factory: 2400001—
Suzuka Factory: 2420001—
K20A3: Saitama Factory: 2100001—
Suzuka Factory: 2120001—

Transmission Number

MRMA - 2000001

|-----|-----|

a b

a. Transmission Type
MRMA: 5-speed Automatic
W2M5: 5-speed Manual
X2M5: 6-speed Manual

b. Serial Number

Paint Code

Code	Color	U.S.	Canada
B-507P	Arctic Blue Pearl	○	○
B-92P	Nighthawk Black Pearl	○	○
B-96P	Eternal Blue Pearl	○	
NH-578	Taffeta White	○	
NH-623M	Satin Silver Metallic	○	○
NH-624P	Premium White Pearl	○	○
NH-636P	Brilliant White Pearl		○
R-81	Milano Red		○
R-522	Redondo Red Pearl	○	
YR-534M	Desert Silver Metallic	○	○

General Information

Chassis and Paint Codes (cont'd)

2004 Model

Vehicle Identification Number

JH4	DC5	3	8	*	4	S	000001
a	b	c	d	e	f	g	h

a. Manufacturer, Make and Type of Vehicle
 JH4: HONDA MOTOR CO., LTD.
 ACURA passenger vehicle

b. Line, Body and Engine Type
 DC5: ACURA RSX/K20A2, K20A3

c. Body Type and Transmission Type
 3: 2-door Hatchback/5-speed Manual
 2-door Hatchback/6-speed Manual
 4: 2-door Hatchback/5-speed Automatic

d. Vehicle Grade (Series)
 U.S. Model Canada Model
 0: Type S 0: Type S
 8: RSX 6: RSX
 8: Premium

e. Check Digit

f. Model Year
 4: 2004

g. Factory Code
 S: Suzuka Factory in Japan

h. Serial Number
 U.S.: 000001—
 Canada: 800001—

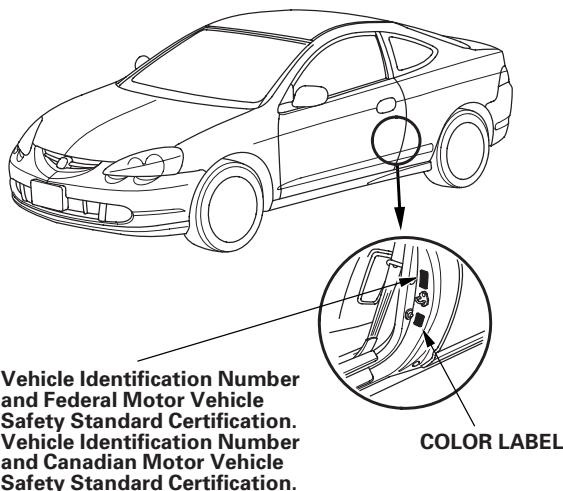

Engine Number

K20A2	-	3300001
a		b

a. Engine Type
 K20A2: 2.0 L DOHC i-VTEC Sequential Multiport Fuel-injected 200 HP engine
 K20A3: 2.0 L DOHC i-VTEC Sequential Multiport Fuel-injected 160 HP engine

b. Serial Number
 K20A2: 3300001—
 K20A3: 3000001—

Transmission Number

MRMA	-	3000001
a		b

a. Transmission Type
 MRMA: 5-speed Automatic
 W2M5: 5-speed Manual
 X2M5: 6-speed Manual

b. Serial Number

Paint Code

Code	Color	U.S.	Canada
B-507P	Arctic Blue Pearl	○	○
B-92P	Nighthawk Black Pearl	○	○
B-96P	Eternal Blue Pearl	○	
NH-578	Taffeta White	○	
NH-623M	Satin Silver Metallic	○	○
NH-624P	Premium White Pearl	○	○
NH-636P	Brilliant White Pearl		○
R-81	Milano Red		○
YR-534M	Desert Silver Metallic	○	○



2005 Model

Vehicle Identification Number

JH4	DC5	3	8	*	5	S	000001
a	b	c	d	e	f	g	h

a. Manufacturer, Make and Type of Vehicle
 JH4: HONDA MOTOR CO., LTD.
 ACURA passenger vehicle

b. Line, Body and Engine Type
 DC5: ACURA RSX/K20Z1, K20A3

c. Body Type and Transmission Type
 3: 2-door Hatchback/5-speed Manual
 2-door Hatchback/6-speed Manual
 4: 2-door Hatchback/5-speed Automatic

d. Vehicle Grade (Series)
 U.S. Model Canada Model
 0: Type S 0: Type S
 8: RSX 6: RSX
 8: Premium

e. Check Digit

f. Model Year
 5: 2005

g. Factory Code
 S: Suzuka Factory in Japan

h. Serial Number
 U.S.: 000001—
 Canada: 800001—

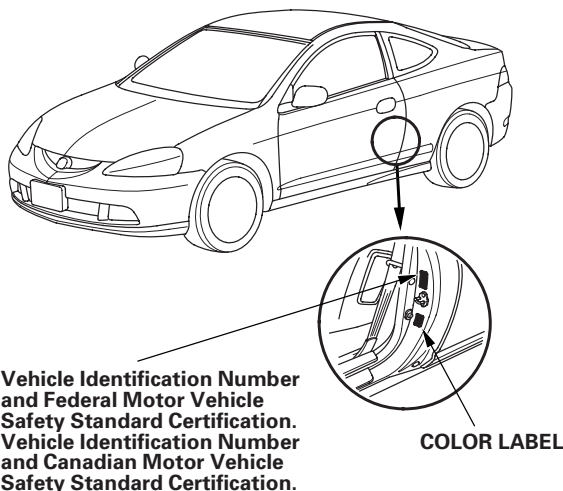

Engine Number

K20Z1	-	1000001
a		b

a. Engine Type
 K20Z1: 2.0 L DOHC i-VTEC Sequential Multiport Fuel-injected 210 HP engine
 K20A3: 2.0 L DOHC i-VTEC Sequential Multiport Fuel-injected 160 HP engine

b. Serial Number
 K20Z1: 1000001—
 K20A3: 4000001—

Transmission Number

MRMA	-	4000001
a		b

a. Transmission Type
 MRMA: 5-speed Automatic
 PTD6: 5-speed Manual
 NSN4: 6-speed Manual

b. Serial Number

Paint Code

Code	Color	U.S.	Canada
B-92P	Nighthawk Black Pearl	○	○
B-520P	Vivid Blue Pearl	○	○
NH-578	Taffeta White	○	
NH-623M	Satin Silver Metallic	○	○
NH-624P	Premium White Pearl	○	○
NH-675M	Magnesium Metallic	○	○
G-523M	Jade Green Metallic	○	
R-81	Milano Red	○	
YR-552M	Blaze Orange Metallic	○	○

General Information

Chassis and Paint Codes (cont'd)

2006 Model

Vehicle Identification Number

JH4	DC5	3	8	*	6	S	000001
a	b	c	d	e	f	g	h

a. Manufacturer, Make and Type of Vehicle
 JH4: HONDA MOTOR CO., LTD.
 ACURA passenger vehicle

b. Line, Body and Engine Type
 DC5: ACURA RSX/K20Z1, K20A3

c. Body Type and Transmission Type
 3: 2-door Hatchback/5-speed Manual
 2-door Hatchback/6-speed Manual
 4: 2-door Hatchback/5-speed Automatic

d. Vehicle Grade (Series)
 U.S. Model Canada Model
 0: Type S 0: Type S
 8: RSX 6: RSX
 8: Premium

e. Check Digit

f. Model Year
 6: 2006

g. Factory Code
 S: Suzuka Factory in Japan

h. Serial Number
 U.S.: 000001—
 Canada: 800001—

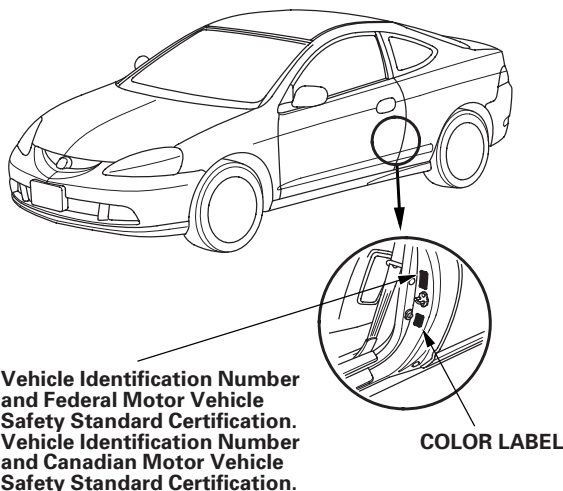

Engine Number

K20Z1	-	2000001
a		b

a. Engine Type
 K20Z1: 2.0 L DOHC i-VTEC Sequential Multiport Fuel-injected 210 HP engine
 K20A3: 2.0 L DOHC i-VTEC Sequential Multiport Fuel-injected 160 HP engine

b. Serial Number
 K20Z1: 2000001—
 K20A3: 5000001—

Transmission Number

MRMA	-	5000001
a		b

a. Transmission Type
 MRMA: 5-speed Automatic
 PTD6: 5-speed Manual
 NSN4: 6-speed Manual

b. Serial Number

Paint Code

Code	Color	U.S.	Canada
B-92P	Nighthawk Black Pearl	○	○
B-520P	Vivid Blue Pearl	○	○
NH-578	Taffeta White	○	
NH-624P	Premium White Pearl	○	○
NH-700M	Alabaster Silver Metallic	○	○
NH-675M	Magnesium Metallic	○	○
G-523M	Jade Green Metallic	○	
R-81	Milano Red	○	
YR-552M	Blaze Orange Metallic	○	○



Identification Number Locations

Vehicle Identification Number (VIN)

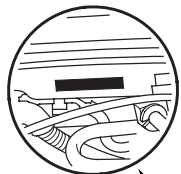

Vehicle Identification Number (VIN)

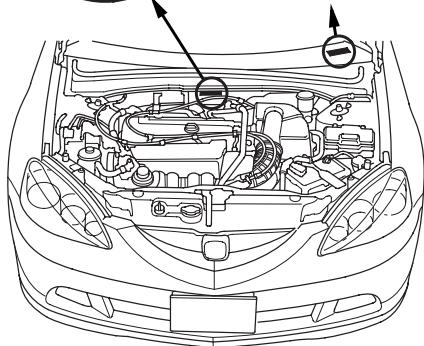
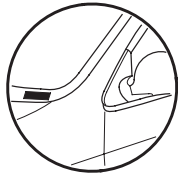

Engine Number

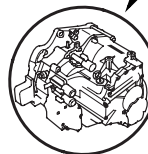
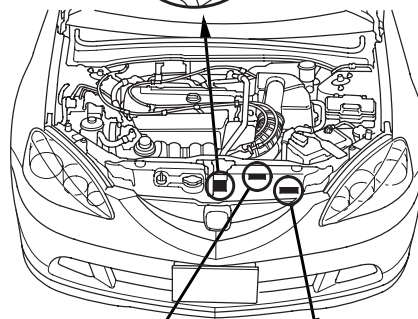
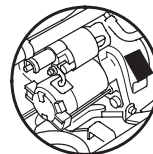

Transmission Number (Automatic)

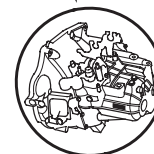

Transmission Number (Manual)

General Information

Danger/Warning/Caution Label Locations

NOTE: FRONT PASSENGER AIRBAG WARNING TAG (CHILD SEAT) is equipped on the glove box in the U.S. model.

Passenger's Compartment:

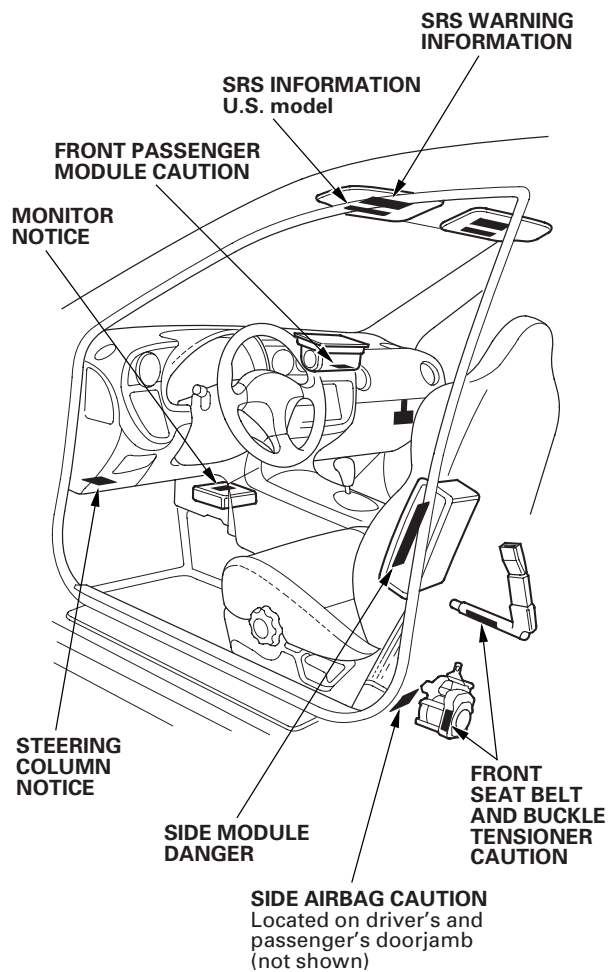

Steering Wheel:

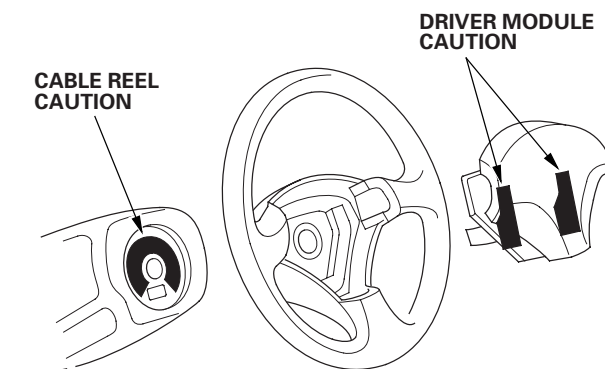

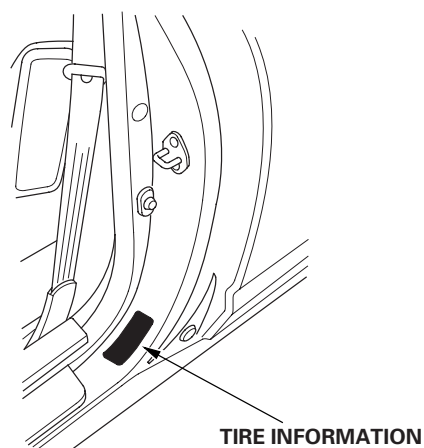
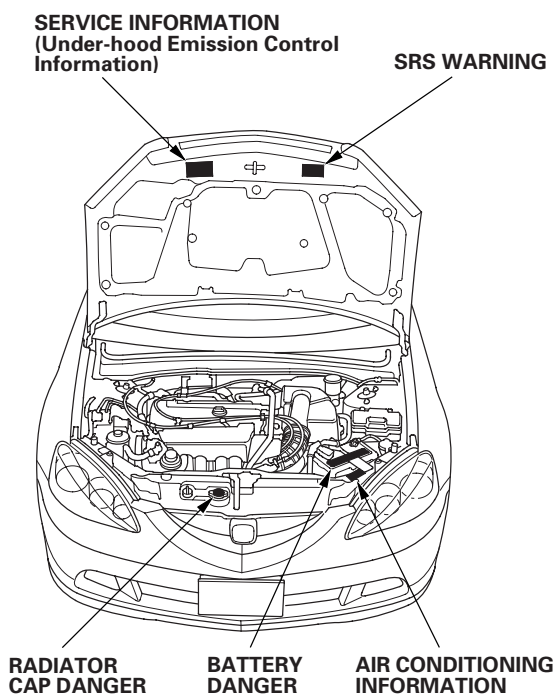

General Information

Under-hood Emission Control Label

Emission Group Identification

2002-2004 Models

Example:



2002 Model:

THIS VEHICLE CONFORMS TO U.S. EPA TIER 2 BIN 5 REGULATIONS APPLICABLE TO 2002 MODEL YEAR NEW BIN 5 PASSENGER CARS AND CALIFORNIA REGULATIONS APPLICABLE TO 2002 MODEL YEAR NEW LEV II LEV PASSENGER CARS.

2003 Model:

THIS VEHICLE CONFORMS TO U.S. EPA TIER 2 REGULATIONS APPLICABLE TO 2003 MODEL YEAR NEW BIN 5 PASSENGER CARS AND CALIFORNIA REGULATIONS APPLICABLE TO 2003 MODEL YEAR NEW LEV II LEV PASSENGER CARS.

2004 Model:

THIS VEHICLE CONFORMS TO U.S. EPA TIER 2 REGULATIONS APPLICABLE TO 2004 MODEL YEAR NEW BIN 5 PASSENGER CARS AND CALIFORNIA REGULATIONS APPLICABLE TO 2004 MODEL YEAR NEW LEV II LEV PASSENGER CARS.

2005-2006 Models

Example:

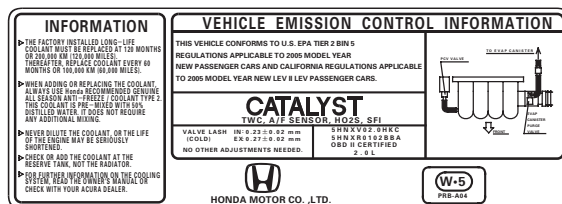

2005 Model: K20Z1 engine

THIS VEHICLE CONFORMS TO U.S. EPA TIER 2 BIN 5 REGULATIONS APPLICABLE TO 2005 MODEL YEAR NEW PASSENGER CARS AND CALIFORNIA REGULATIONS APPLICABLE TO 2005 MODEL YEAR NEW LEV II LEV PASSENGER CARS.

2005 Model: K20A3 engine

THIS VEHICLE CONFORMS TO U.S. EPA TIER 2 BIN 5 AND CFV LEV REGULATIONS APPLICABLE TO 2005 MODEL YEAR NEW PASSENGER CARS AND CALIFORNIA REGULATIONS APPLICABLE TO 2005 MODEL YEAR NEW LEV II LEV PASSENGER CARS. EPA CERTIFICATION TEST FUEL FOR CFV: EPA UNLEADED GASOLINE.

2006 Model:

THIS VEHICLE CONFORMS TO U.S. EPA TIER 2 BIN 5 REGULATIONS APPLICABLE TO 2006 MODEL YEAR NEW PASSENGER CARS AND CALIFORNIA REGULATIONS APPLICABLE TO 2006 MODEL YEAR NEW LEV II LEV PASSENGER CARS.



Test Group and Evaporative Family

Test Group:

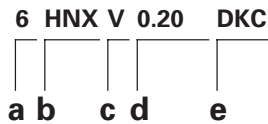

a. Model Year

- 2: 2002
- 3: 2003
- 4: 2004
- 5: 2005
- 6: 2006

b. Manufacturer Subcode

HNX: HONDA

c. Family Type

V: LDV

d. Displacement Group

0.20: 2002-2004 Models and 2005-2006 K20Z1 engine Models and 2006 K20A3 engine Model

0.24: 2005 K20A3 engine Model

e. Sequence Characters

VBP (L-K, L-M), EKC-Type S (L-L, L-N): 2002 Model
XKC (P5, P6), SKC-Type S (P7, P8): 2003-2004 Models
HKC: 2005 K20Z1 engine Model
KBP: 2005 K20A3 engine Model
DKC: 2006 K20Z1, K20A3 engine Models

Evaporative Family:

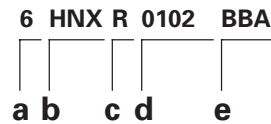

a. Model Year

- 2: 2002
- 3: 2003
- 4: 2004
- 5: 2005
- 6: 2006

b. Manufacturer Subcode

HNX: HONDA

c. Family Type

R: EVAP/ORVR

d. Canister Work Capacity

0099: 2002-2004 Models

0102: 2005-2006 Models

e. Sequence Characters

AAH: 2002 Model

AAA: 2003-2004 Models

BBA: 2005-2006 Models

General Information

Lift and Support Points

NOTE: If you are going to remove heavy components such as suspension or the fuel tank from the rear of the vehicle, first support the front of the vehicle with tall safety stands. When substantial weight is removed from the rear of the vehicle, the center of gravity can change and cause the vehicle to tip forward on the hoist.

Frame Hoist

1. Position the hoist lift blocks (A), on safety stands, under the vehicle's front support points (B) and rear support points (C).

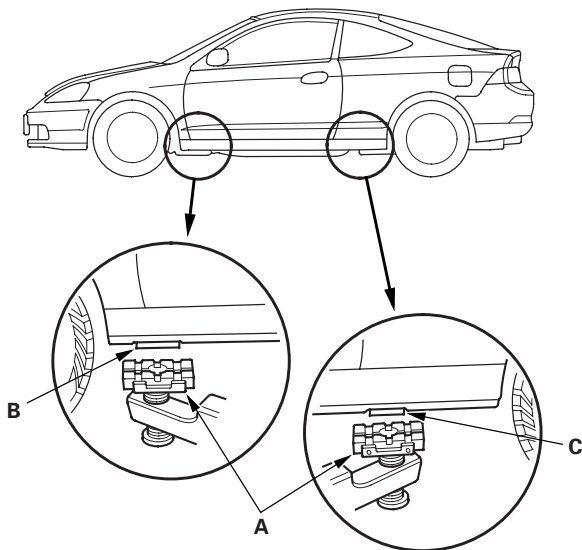

2. Raise the hoist a few inches, and rock the vehicle gently to be sure it is firmly supported.
3. Raise the hoist to full height, and inspect the lift points for solid contact with the lift blocks.

Safety Stands

To support the vehicle on safety stands, use the same support points (B and C) as for a frame hoist. Always use safety stands when working on or under any vehicle that is supported only by a jack.

Floor Jack

1. Set the parking brake.
2. Block the wheels that are not being lifted.
3. When lifting the rear of the vehicle, put the shift lever in reverse, or the automatic transmission in the P position.
4. Position the floor jack under the front jacking bracket (A) or rear jacking bracket (B), center the jacking bracket in the jack lift platform (C), and jack up the vehicle high enough to fit the safety stands under it.

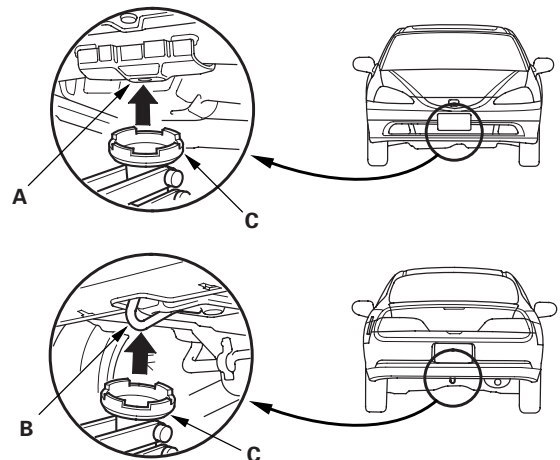

5. Position the safety stands under the support points and adjust them so the vehicle is level.
6. Lower the vehicle onto the stands.



Towing

If the vehicle needs to be towed, call a professional towing service. Never tow the vehicle behind another vehicle with just a rope or chain. It is very dangerous.

Emergency Towing

There are three popular methods of towing a vehicle.

Flat-bed Equipment — The operator loads the vehicle on the back of a truck. This is the best way of transporting the vehicle.

To accommodate flat-bed equipment, the vehicle is equipped with towing hooks (A) and tie down hooks (B).

The towing hook can be used with a winch to pull the vehicle onto the truck, and the tie down hook slots can be used to secure the vehicle to the truck.

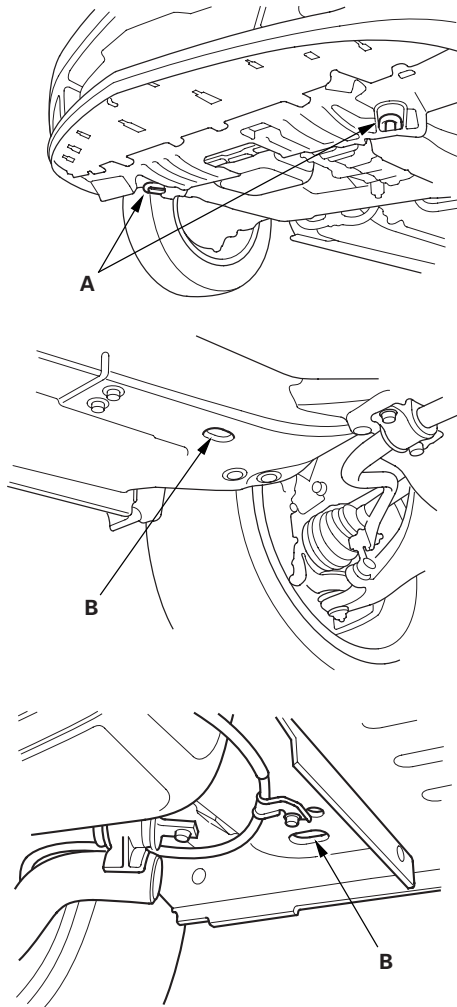

Wheel Lift Equipment — The tow truck uses two pivoting arms that go under the tires (front or rear) and lifts them off the ground. The other two wheels remain on the ground. This is an acceptable way of towing the vehicle.

Sling-type Equipment — The tow truck uses metal cables with hooks on the ends. These hooks go around parts of the frame or suspension and the cables lift that end of the vehicle off the ground. The vehicle's suspension and body can be seriously damaged if this method of towing is attempted.

If the vehicle cannot be transported by flat-bed, it should be towed with the front wheels off the ground. If due to damage, the vehicle must be towed with the front wheels on the ground, do the following:

Manual Transmission

- Release the parking brake.
- Shift the transmission to Neutral.

Automatic Transmission

- Release the parking brake.
- Start the engine.
- Shift to the D position, then to the N position.
- Turn off the engine.

It is best to tow the vehicle no farther than 50 miles (80 km), and keep the speed below 35 mph (55 km/h).

NOTICE

- Improper towing preparation will damage the transmission. Follow the above procedure exactly. If you cannot shift the transmission or start the engine (automatic transmission), the vehicle must be transported on a flat-bed.
- Trying to lift or tow the vehicle by the bumpers will cause serious damage. The bumpers are not designed to support the vehicle's weight.

General Information

Parts Marking

To deter vehicle theft, certain major components are marked with the vehicle identification number (VIN). Original parts have self-adhesive labels. Replacement body parts have generic self-adhesive labels. These labels should not be removed. The original engine or transmission VIN plates are not transferable to the replacement engine or transmission.

NOTE: Be careful not to damage the parts marking labels during body repair. Mask the labels before repairing the part.

Standards and Service Limits

Engine Electrical

Item	Measurement	Qualification	Standard or New	Service Limit
Ignition coil	Rated voltage		12 V	
	Firing order		1—3—4—2	
Spark plug	Type	K20A3 engine	NGK: IZFR6K11 DENSO: SKJ20DR-M11	
		K20A2 engine (2002-2004 models)	NGK: IFR7G11K, IFR7G11KS DENSO: SK22PR-M11, SK22PR-M11S	
		K20Z1 engine (2005-2006 models)	NGK: IFR7G11KS DENSO: SK22PR-M11S	
	Gap		1.0—1.1 mm (0.039—0.043 in.)	1.3 mm (0.051 in.)
Ignition timing	At idle	M/T (in neutral)	8°±2° BTDC	
	Check the <i>red</i> mark	A/T (in N or P position)	8°±2° BTDC	
Drive belt	Tension		Auto tensioner	
Alternator (K20A3 engine)	Output	At 13.5 V and normal engine temperature	90 A	
	Coil (rotor) resistance	At 68°F (20°C)	1.84—2.10 Ω	
	Slip ring O.D.		22.7 mm (0.89 in.)	21.7 mm (0.85 in.)
	Brush length		15.5 mm (0.61 in.)	1.5 mm (0.06 in.)
	Brush spring tension		3.3—4.1 N (0.34—0.42 kgf, 0.7—0.9 lbf)	
Alternator [K20A2 (2002-2004 models), K20Z1 (2005-2006 models) engines]	Output	At 13.5 V and normal engine temperature	95 A	
	Coil (rotor) resistance	At 68°F (20°C)	2.2—3.0 Ω	
	Slip ring O.D.		14.4 mm (0.57 in.)	14.0 mm (0.55 in.)
	Brush length		10.5 mm (0.41 in.)	1.5 mm (0.06 in.)
	Brush spring tension		2.9—3.5 N (0.30—0.36 kgf, 0.7—0.8 lbf)	
Starter (K20A3 engine)	Output		1.2 kW	
	Commutator mica depth		0.40—0.50 mm (0.016—0.020 in.)	0.15 mm (0.006 in.)
	Commutator runout		0.02 mm (0.001 in.) max.	0.05 mm (0.002 in.)
	Commutator O.D.		28.0—28.1 mm (1.102—1.106 in.)	27.5 mm (1.083 in.)
	Brush length		11.1—11.5 mm (0.44—0.45 in.)	4.3 mm (0.17 in.)
Starter [K20A2 (2002-2004 models), K20Z1 (2005-2006 models) engines]	Output		1.1 kW	
	Commutator mica depth		0.50—0.80 mm (0.020—0.031 in.)	0.20 mm (0.008 in.)
	Commutator runout		0.02 mm (0.001 in.) max.	0.05 mm (0.002 in.)
	Commutator O.D.		28.0 mm (1.10 in.)	27.0 mm (1.06 in.)
	Brush length		14.0—14.5 mm (0.55—0.57 in.)	9.0 mm (0.35 in.)
	Brush spring tension		13.7—17.7 N (1.40—1.80 kgf, 3.09—3.97 lbf)	

Engine Assembly

Item	Measurement	Qualification	Standard or New	Service Limit
Compression	Pressure	Minimum	930 kPa (9.5 kgf/cm ² , 135 psi)	————
	Check the engine with the starter cranking	Maximum variation	200 kPa (2.0 kgf/cm ² , 28 psi)	————

Cylinder Head

Item	Measurement	Qualification	Standard or New	Service Limit	
Head	Warpage		————	0.05 mm (0.002 in.)	
	Height		103.95—104.05 mm (4.093—4.096 in.)	————	
Camshaft	End play		0.05—0.20 mm (0.002—0.008 in.)	0.4 mm (0.02 in.)	
	Camshaft-to-holder oil clearance	No. 1 journal	0.030—0.069 mm (0.001—0.003 in.)	0.15 mm (0.006 in.)	
		No. 2, 3, 4, 5 journals	0.060—0.099 mm (0.002—0.004 in.)	0.15 mm (0.006 in.)	
	Total runout		0.03 mm (0.001 in.) max.	0.04 mm (0.002 in.)	
	Cam lobe height (K20A3 engine)	Intake, primary		33.925 mm (1.3356 in.)	————
		Intake, secondary		29.638 mm (1.1668 in.)	————
		Exhaust		34.092 mm (1.3422 in.)	————
	Cam lobe height [K20A2 (2002-2004 models), K20Z1 (2005-2006 models) engines]	Intake, primary		32.791 mm (1.2910 in.)	————
		Intake, mid		35.534 mm (1.3990 in.)	————
		Intake, secondary		32.678 mm (1.2865 in.)	————
		Exhaust, primary		32.772 mm (1.2902 in.)	————
		Exhaust, mid		34.768 mm (1.3688 in.)	————
		Exhaust, secondary		32.661 mm (1.2859 in.)	————

(cont'd)

Standards and Service Limits

Cylinder Head (cont'd)

Item	Measurement	Qualification	Standard or New	Service Limit
Valve	Clearance (cold)	Intake	0.21—0.25 mm (0.008—0.010 in.)	———
		Exhaust (K20A3 engine)	0.28—0.32 mm (0.011—0.013 in.)	———
		Exhaust [K20A2 (2002-2004 models), K20Z1 (2005-2006 models) engines]	0.25—0.29 mm (0.010—0.011 in.)	———
	Stem O.D.	Intake	5.475—5.485 mm (0.2156—0.2159 in.)	5.445 mm (0.214 in.)
		Exhaust	5.450—5.460 mm (0.2146—0.2150 in.)	5.42 mm (0.213 in.)
	Stem-to-guide clearance	Intake	0.030—0.055 mm (0.0012—0.0022 in.)	0.08 mm (0.003 in.)
Exhaust		0.055—0.080 mm (0.0022—0.0031 in.)	0.11 mm (0.004 in.)	
Valve seat	Width	Intake	1.25—1.55 mm (0.049—0.061 in.)	2.00 mm (0.079 in.)
		Exhaust	1.25—1.55 mm (0.049—0.061 in.)	2.00 mm (0.079 in.)
	Stem installed height	Intake	44.0—44.5 mm (1.73—1.75 in.)	44.7 mm (1.76 in.)
		Exhaust	44.1—44.6 mm (1.74—1.76 in.)	44.8 mm (1.76 in.)
Valve spring	Free length (K20A3 engine)	Intake	47.61 mm (1.874 in.)	———
		Exhaust	NIPPON HATSUJO: 49.64 mm (1.954 in.) CHUO HATSUJO: 49.63 mm (1.954 in.)	———
	Free length [K20A2 (2002 model) engine]	Intake, inner	45.22 mm (1.780 in.)	———
		Exhaust, inner	45.50 mm (1.791 in.)	———
		Intake, outer	50.86 mm (2.002 in.)	———
		Exhaust, outer	51.81 mm (2.040 in.)	———
	Free length [K20A2 (2003-2004 models), K20Z1 (2005-2006 models) engines]	Intake	49.77 mm (1.959 in.)	———
		Exhaust	50.39 mm (1.984 in.)	———
	Valve guide	I.D.	Intake	5.515—5.530 mm (0.2171—0.2177 in.)
Exhaust			5.515—5.530 mm (0.2171—0.2177 in.)	5.55 mm (0.219 in.)
Installed height		Intake	15.2—16.2 mm (0.598—0.638 in.)	———
		Exhaust	15.5—16.5 mm (0.610—0.650 in.)	———
Rocker arm	Arm-to-shaft clearance	Intake	0.025—0.052 mm (0.0010—0.0020 in.)	0.08 mm (0.003 in.)
		Exhaust (K20A3 engine)	0.018—0.056 mm (0.0007—0.0022 in.)	0.08 mm (0.003 in.)
		Exhaust [K20A2 (2002-2004 models), K20Z1 (2005-2006 models) engines]	0.025—0.052 mm (0.0010—0.0020 in.)	0.08 mm (0.003 in.)

Engine Block

Item	Measurement	Qualification	Standard or New	Service Limit
Block	Warpage of deck		0.07 mm (0.003 in.) max.	0.10 mm (0.004 in.)
	Bore diameter	A or I	86.010—86.020 mm (3.3862—3.3866 in.)	86.070 mm (3.3886 in.)
		B or II	86.000—86.010 mm (3.3858—3.3862 in.)	86.070 mm (3.3886 in.)
	Bore taper		————	0.05 mm (0.002 in.)
	Reboring limit		————	0.25 mm (0.01 in.)
Piston	Skirt O.D. at 11 mm (0.4 in.) from bottom of skirt	No letter or A	85.980—85.990 mm (3.3850—3.3854 in.)	85.930 mm (3.3831 in.)
		Letter B	85.970—85.980 mm (3.3846—3.3850 in.)	85.920 mm (3.3827 in.)
	Clearance in cylinder		0.020—0.040 mm (0.0008—0.0016 in.)	0.05 mm (0.002 in.)
	Ring groove width	Top (K20A3 engine)	1.220—1.230 mm (0.0481—0.0484 in.)	1.25 mm (0.049 in.)
		Top [K20A2 (2002-2004 models), K20Z1 (2005-2006 models) engines]	1.235—1.245 mm (0.0486—0.0490 in.)	1.265 mm (0.0498 in.)
		Second (K20A3 engine)	1.220—1.230 mm (0.0481—0.0484 in.)	1.25 mm (0.049 in.)
		Second [K20A2 (2002-2004 models), K20Z1 (2005-2006 models) engines]	1.230—1.240 mm (0.0484—0.0488 in.)	1.260 mm (0.0496 in.)
	Oil		2.005—2.025 mm (0.0789—0.0797 in.)	2.05 mm (0.081 in.)

(cont'd)